

PPWAMD300 Power Supply Series (300W)

Features:

- IEC 60601-1-2 4th Edition EMC Compliant
- Class I and Class II Versions
- Medical and ITE Approvals
- Meets Efficiency Level VI Requirements
- BF (Body Floating) Rated Output
- Overload Protection
- Short Circuit Protection
- No Load Operation
- IP42 Enclosure



Description:

The PPWAMD300 is a compact, desktop AC-DC switching power supply that offers both ITE and Medical approvals. This 8.74" x 4.4" platform offers up to 300W of continuous power across a wide range of operating temperatures, all while maintaining a low emissions profile. All models meet FCC, EN55011, CISPR11 class B emission limits, and comply with UL, CE, IEC, and more.

Model ^{1,2}	Output Voltage	Current	Total Power	Load Regulation	Ripple & Noise (P-P) ³	Efficiency Level
PPWAMD300-12	12V	25A	300W	±5%	240mV	VI
PPWAMD300-13-2	19V	15.79A	300W	±5%	300mV	VI
PPWAMD300-14	24V	12.5A	300W	±5%	300mV	VI
PPWAMD300-15	28V	10.71A	300W	±5%	300mV	VI
PPWAMD300-18	48V	6.25A	300W	±5%	300mV	VI
PPWAMD300-18-1	54V	5.56A	300W	±5%	300mV	VI

NOTES:

1. C14 Standard Receptacle. For C18 input receptacle, model numbers are PPWAMD300F, For Example PPWAMD300F-12.
2. For switch option model numbers are PPWAMD300-XX-S, for example PPWAMD300-12-S.
3. Ripple and noise are measured at 20MHz bandwidth with a 47uF electrolytic capacitor and a.1uF ceramic capacitor in parallel at output connector.

Specifications	
Input	
Input Voltage	90-264VAC
Input Frequency	47-63Hz
Input Current	3A max at 115VAC 1.5A max at 230VAC
Inrush Current	<35A peak at 115VAC, <70A peak at 230VAC, cold start, 25°C
Power Factor	>0.95 at 115VAC full load >0.90 at 230VAC full load
Output	
Total Output Power	300W max
Output Voltage	See table
Hold Up Time	>10mS at full load and 115VAC nominal
Touch Current	<100uA max. at 264VAC, 60Hz
Average Active Efficiency	>88% with 115VAC/60Hz & 230Vac/50Hz input voltage (meets DOE level VI requirements)
No Load Power Consumption	<500mW
Turn on Delay	<3 seconds
Protection Features	
Overvoltage Protection	110-150% of nominal output voltage. Latching type, cycle AC to reset
Overload Protection	105%-150% of maximum output rating, Auto recovery
Short Circuit Protection	Hiccup mode. Auto recovery
Ingress	IP42 Compliant
Environmental	
Operating Temperature	-30°C to +60°C (refer to derating curve)
Storage Temperature	-20°C to +85°C
Humidity	0% to 90% non-condensing
Operating Altitude	<5000m operational and storage
General Specifications	
Dimensions	8.74"(222mm) x 4.4"(112mm) x 1.77"(45mm)
Ac Input Receptacle	IEC60320 C14, C18
DC Output Plug	10-pin Molex mini-fit, 4.2mm pitch. Others available upon request
Weight	3.46lbs
MTBF	>200K hours per Bellcore TR-332 at full load and 25°C ambient

Specifications Continued	
Safety	
Approvals USA/Canada	ANSI/AAMI ES60601-1 cUL ES60601-1
Approvals Europe	TUV EN60601-1 4th edition CB Report
Isolation	4000VAC input to output, 2 x MOPP 1500 VAC input to ground, 1 x MOPP
*Consult with TT Electronics for information on additional country safety approvals	
EMC	
Emissions	FCC Class B Radiated & Conducted CISPR11 Class B Radiated & Conducted EN55011 Class B Radiated & Conducted
Susceptibility	
Harmonic Currents	IEC 61000-3-2: Class A and D
Voltage Flicker	IEC 61000-3-3
Electrostatic Discharge	IEC 61000-4-2
Radiated Immunity	IEC 61000-4-3
EFT/Burst	IEC 61000-4-4
Surge Immunity	IEC 61000-4-5
Conducted Immunity	IEC 61000-4-6
Magnetic Field	IEC 61000-4-8
Dips/Interruptions	IEC 61000-4-11

Diagrams

Mechanical Outline

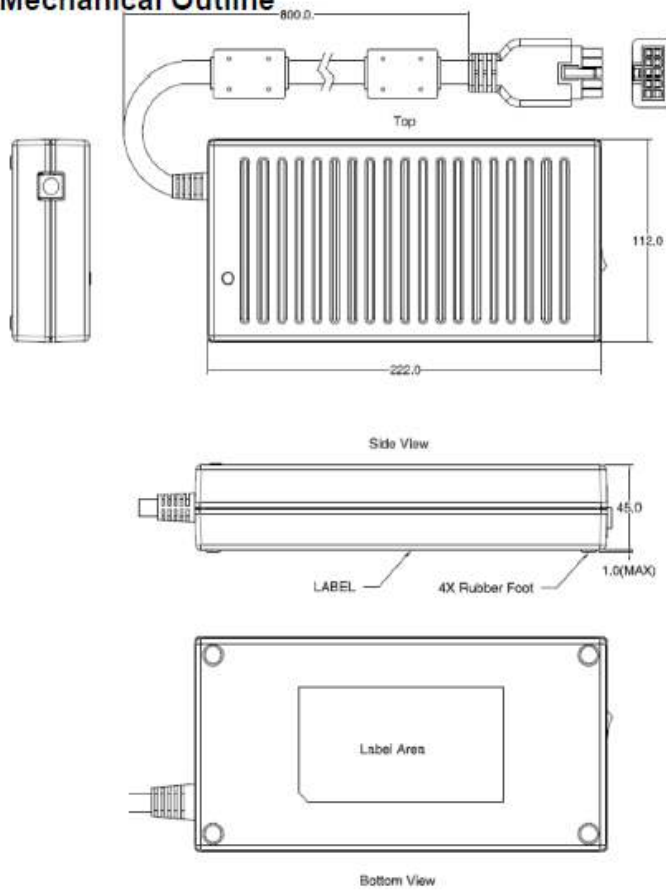

Connector Detail

