

# SI-8000Y Series Current Mode Control Step-down Switching Mode Regulator ICs

## ■ Features

- Compact (equivalent to TO220) full-mold package
- Output current: 8.0 A
- High efficiency: 86%
- Built-in reference oscillator (130 kHz)
- Built-in drooping-type-overcurrent protection and thermal protection circuits
- Built-in soft start circuit (Output ON/OFF available)
- Low current consumption during off

## ■ Absolute Maximum Ratings

Parameter	Symbol	Ratings	Unit
Input Voltage	$V_{IN}$	45	V
Power Dissipation	$P_{D1}$	20.8(With infinite heatsink)	W
	$P_{D2}$	1.8(Without heatsink, stand-alone operation)	W
Junction Temperature	$T_j$	-30 to +150	°C
Storage Temperature	$T_{stg}$	-40 to +150	°C
Thermal Resistance (Junction to Case)	$\theta_{j-c}$	6	°C/W
Thermal Resistance (Junction to Ambient Air)	$\theta_{j-a}$	66.7	°C/W

## ■ Applications

- AV equipment
- OA equipment
- Gaming equipment
- Onboard local power supplies

## ■ Recommended Operating Conditions

Parameter	Symbol	Ratings		Unit
		SI-8010Y	SI-8050Y	
Input Voltage Range	$V_{IN}$	8 or $V_o+3^*$ to 43	8 to 43	V
Output Voltage Range	$V_o$	1 to 15	5	V
Output Current Range	$I_o$	0 to 8.0		A
Operating Junction Temperature Range	$T_{jop}$	-30 to +135		°C
Operating Temperature Range	$T_{op}$	-30 to +85		°C

\*: The minimum value of the input voltage range is 8 V or  $V_o + 3V$ , whichever is higher.

## ■ Electrical Characteristics

Parameter	Symbol	Ratings						Unit
		SI-8010Y*			SI-8050Y			
		min.	typ.	max.	min.	typ.	max.	
Output Voltage (Reference voltage for SI-8010Y)	$V_o(V_{REF})$	0.98	1.00	1.02	4.90	5.00	5.10	V
Temperature Coefficient of Output Voltage (Reference voltage temperature coefficient for SI-8010Y)	$\Delta V_o/\Delta T(\Delta V_{REF}/\Delta T)$	$\pm 0.1$						mV/°C
	Conditions	$V_{IN}=30V, I_o=0.1A, T_a=25^\circ C$			$V_{IN}=30V, I_o=0.1A, T_a=0 \text{ to } 100^\circ C$			
Efficiency	$\eta$	86						%
	Conditions	$V_{IN}=30V, I_o=3A$			$V_{IN}=30V, I_o=3A$			
Oscillation Frequency	$f_o$	130						kHz
	Conditions	$V_{IN}=30V, I_o=3A$			$V_{IN}=30V, I_o=3A$			
Line Regulation	$\Delta V_{OLINE}$	30	90		30	90		mV
	Conditions	$V_{IN}=10 \text{ to } 43V, I_o=3A$			$V_{IN}=10 \text{ to } 43V, I_o=3A$			
Load Regulation	$\Delta V_{LOAD}$	30	90		30	90		mV
	Conditions	$V_{IN}=30V, I_o=0.1 \text{ to } 8A$			$V_{IN}=30V, I_o=0.1 \text{ to } 8A$			
Overcurrent Protection Starting Current	$I_s$	8.1						A
	Conditions	$V_{IN}=20V$			$V_{IN}=20V$			
Quiescent Circuit Current	$I_q$	8						mA
	Conditions	$V_{IN}=30V, I_o=0A, EN/SS=open$			$V_{IN}=30V, I_o=0A, EN/SS=open$			
	$I_{q(OFF)}$	200	500		200	500		
EN/SS Pin*	Outflow Current at Low Voltage	$I_{SSL}$	10	30		10	30	$\mu A$
		Conditions	$V_{IN}=30V, EN/SS=0V$			$V_{IN}=30V, EN/SS=0V$		
	Low Level Voltage	$V_{SSL}$		0.5			0.5	V
Error Amplifier Voltage Gain	AEA		300			300		V/V
Error Amplifier Transformer Conductance	GEA		800			800		$\mu A/V$
Current Sense Amplifier Impedance	1/GCS		0.16			0.16		V/A
Maximum ON Duty	DMAX		92			92		%
Minimum ON Time	DMIN		200			200		nsec

\*:  $R1=8k\Omega, R2=2k\Omega$  when  $T_a=25^\circ C$  and  $V_o=5V$

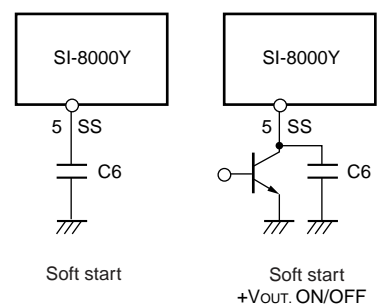

External Dimensions (TO220F-7)

(Unit : mm)

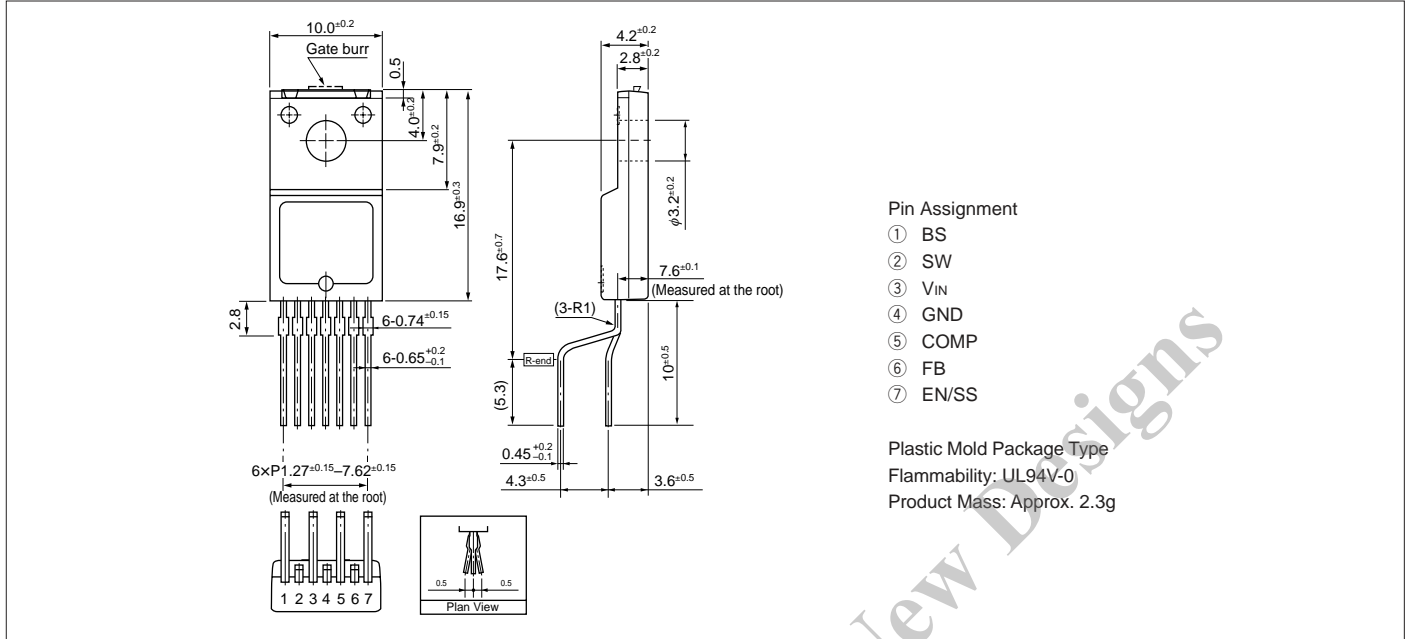

Block Diagram



Typical Connection Diagram

