

REVISIONS					
REV	ECO	DESCRIPTION	DATE	BY	APPR
A1	--	FIRST RELEASED	Sep-28-2018	White	Tommy
A2	--	UPDATED DRAWING	Jan-09-2019	White	Tommy

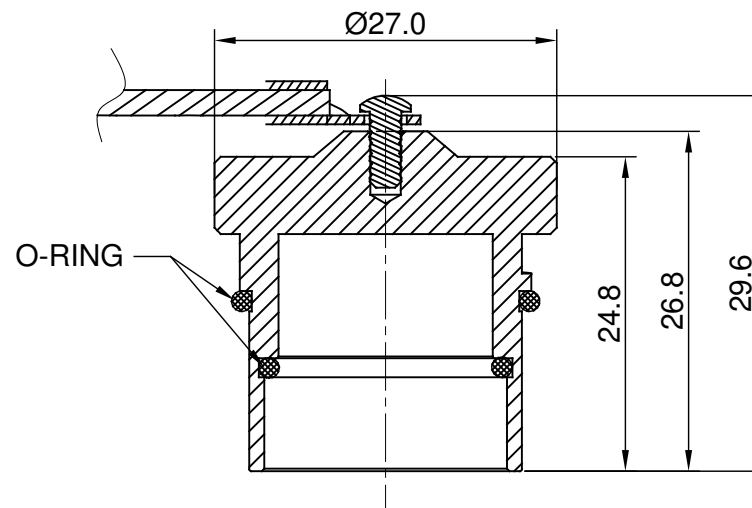
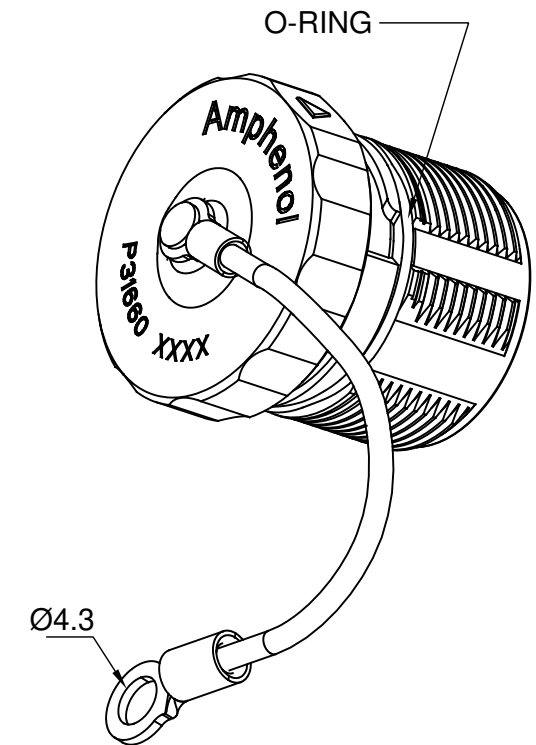
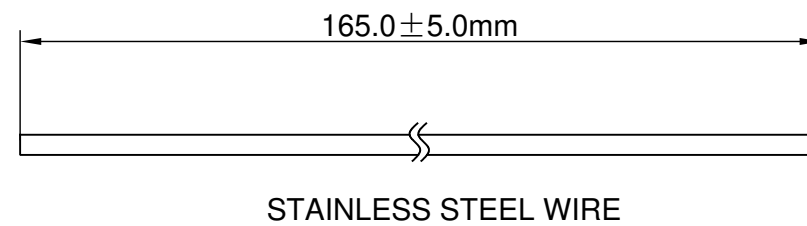
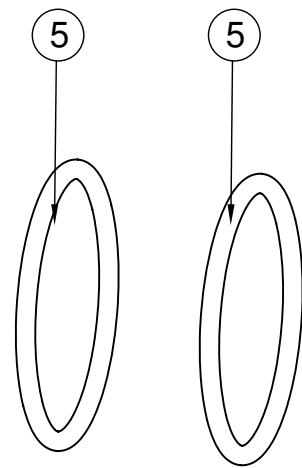
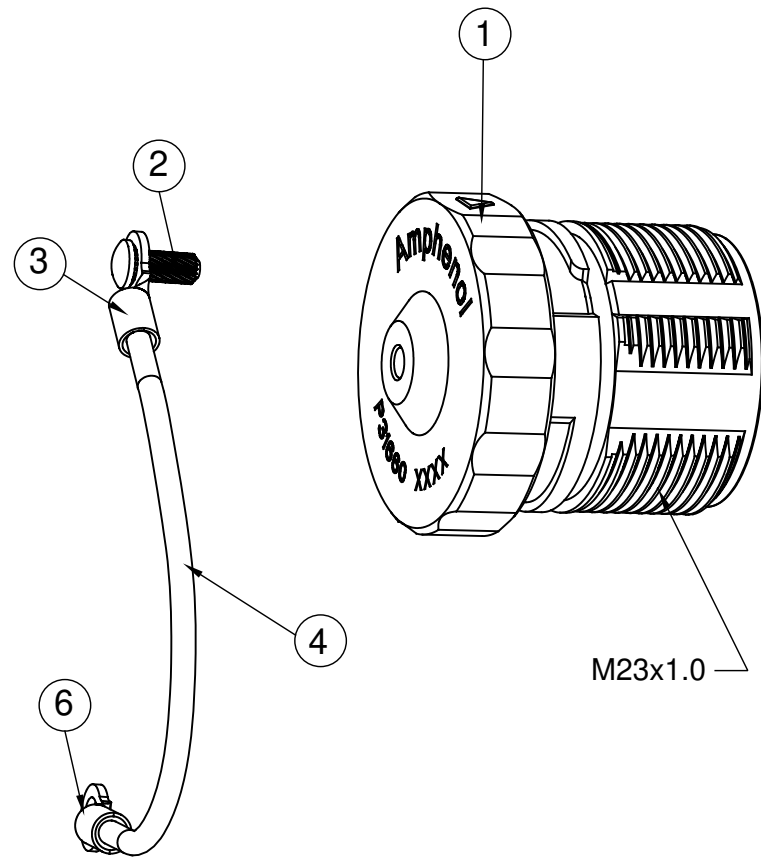

NOTES : (UNLESS OTHERWISE SPECIFIED)

- MATERIAL :  
NUT : ZINC DIE CAST, NICKEL PLATED.  
RIVET : STAINLESS STEEL.  
WIRE : STAINLESS STEEL.  
SEAL: VITON.
- SPECIFICATIONS :  
2.1 MATING CYCLES DURABILITY : 500 CYCLES MIN.  
2.2 IP--CLASS : IP67 (IN MATED CONDITION)  
2.3 RoHS COMPLIANT.
- ALL DIMENSIONS ARE FOR REFERENCE USE ONLY.

TITLE: DUST CAP FOR M23A THREAD PLUG  
DWG NO: P31660  
REV: A2  
SH: 1  
OF: 1

QUANTITY	PART NUMBER	DESCRIPTION	ITEM
1	RRNBL14	RING TERMIANL M4	6
1	RB000024	O-RING, 17.5MM(ID)*1.6MM, BLACK VITON	5
165mm	RM0061	STAINLESS STEEL WIRE	4
1	RSC000021	RING TERMIANL,M3	3
1	RM0084	RIVET,F2.5*6.35	2
1	CP-M0837	METAL COUPLING NUT	1

**MATERIALS LIST**

UNLESS OTHERWISE SPECIFIED 1) All dimensions are in metric(mm). 2) Tolerances are as follows: 1 PL DEC ±0.30 2 PL DEC ±0.15 3 PL DEC ±0.08 Fractions ±1/64 Angles ±1° 3) Note reference =	SIGNATURES		DATE	<h1>Amphenol</h1> Sine Systems - www.amphenol-sine.com 44724 Morley Drive Clinton Township, MI 48036
	DRAWN: White	Jan-09-2019	CHECKED: Tod	
MATERIAL SPECIFICATIONS:	ENGINEER:	APPROVAL: Tommy	Jan-09-2019	DUST CAP FOR M23A THREAD PLUG
	PROCESS SPECIFICATIONS:	CUSTOMER:	THIS DRAWING IS SUPPLIED FOR INFORMATION ONLY. DESIGN FEATURES, SPECIFICATIONS AND PERFORMANCE DATA SHOWN HEREON ARE THE PROPERTY OF THE AMPHENOL CORPORATION. NO RIGHTS OF REPRODUCTION ARE IMPLIED. ALL DIMENSIONS ARE SUBJECT TO NORMAL MANUFACTURING VARIATIONS.	
NEXT ASSY:	SIZE: B	TYPE: C-	DWG NO: P31660	REVISION: A2
	SCALE: NONE		SHEET 1 OF 1	