

## General Description

The 83PN156I is a programmable LVPECL synthesizer that is “forward” footprint compatible with standard 5mm x 7mm oscillators. The device uses IDT’s fourth generation FemtoClock® NG technology for an optimum of high clock frequency and low phase noise performance. Forward footprint compatibility means that a board designed to accommodate the crystal oscillator interface and the optional control pins is also fully compatible with a canned oscillator footprint - the canned oscillator will drop onto the 10-VFQFN footprint for second sourcing purposes. This capability provides designers with programability and lead time advantages of silicon/crystal based solutions while maintaining compatibility with industry standard 5mm x 7mm oscillator footprints for ease of supply chain management. Oscillator-level performance is maintained with IDT’s 4<sup>th</sup> Generation FemtoClock® NG PLL technology, which delivers sub 0.5ps rms phase jitter.

The 83PN156I defaults to 156.25MHz using a 25MHz crystal with 2 programming pins floating but can also be set to 4 different frequency multiplier settings to support a wide variety of applications. The below table shows some of the more common application settings.

## Features

- Fourth Generation FemtoClock® Next Generation (NG) technology
- Footprint compatible with 5mm x 7mm differential oscillators
- One differential LVPECL output pair
- Crystal oscillator interface which can also be overdriven using a single-ended reference clock
- Output frequency range: 100MHz –156.25MHz
- Crystal/input frequency range: 20MHz – 25MHz, parallel resonant crystal
- VCO range: 2GHz – 2.5GHz
- RMS phase jitter @ 156.25MHz, 12kHz – 20MHz: 0.348ps (typical)
- Full 3.3V or 2.5V operating supply
- -40°C to 85°C ambient operating temperature
- Available in lead-free (RoHS 6) package

## Common Applications and Settings

FSEL1:FSEL0	XTAL (MHz)	Output Frequency (MHz)	Application(s)
00	25	100	PCI Express
01	25	125	Ethernet
10	25	150	SAS, Embedded Processor
11 (default)	25	156.25	10 Gigabit Ethernet XAU1, Rocket IO (default)

## Block Diagram

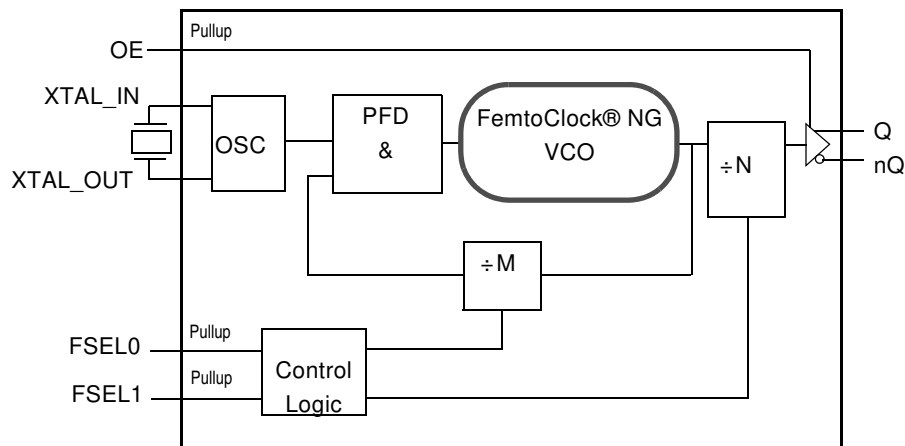

## Pin Assignment

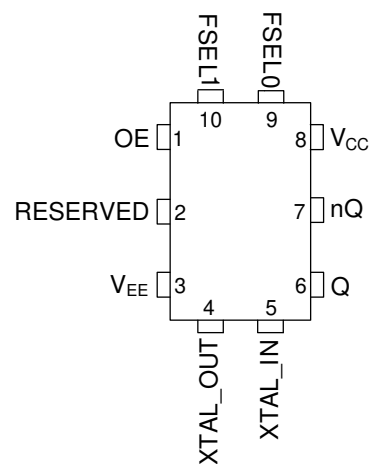

**83PN156I**  
**10-Lead VFQFN**  
**5mm x 7mm x 1mm**  
**package body**  
**K Package**  
**Top View**

### Table 1. Pin Descriptions

Number	Name	Type		Description
1	OE	Input	Pullup	Output enable. LVCMOS/LVTTL interface levels.
2	RESERVED	Reserve		Reserved pin. Do not connect.
3	V <sub>EE</sub>	Power		Negative supply pin.
4, 5	XTAL_OUT XTAL_IN	Input		Crystal oscillator interface XTAL_IN is the input, XTAL_OUT is the output. Crystal oscillator interface which can also be overdriven using a single-ended reference clock.
6, 7	Q, nQ	Output		Differential output pair. LVPECL interface levels.
8	V <sub>CC</sub>	Power		Power supply pin.
9	FSEL0	Input	Pullup	Output divider control inputs. Sets the output divider value to one of four values. See Table 3. LVCMOS/LVTTL interface levels.
10	FSEL1	Input	Pullup	Output divider control inputs. Sets the output divider value to one of four values. See Table 3. LVCMOS/LVTTL interface levels

NOTE: Pullup refers to internal input resistors. See Table 2, *Pin Characteristics*, for typical values.

### Table 2. Pin Characteristics

Symbol	Parameter	Test Conditions	Minimum	Typical	Maximum	Units
C <sub>IN</sub>	Input Capacitance			4		pF
R <sub>PULLUP</sub>	Input Pullup Resistor			51		kΩ

## Function Table

### Table 3. Divider Function Table

FSEL[1:0]	M Value	N Value
0 0	80	÷20
0 1	80	÷16
1 0	84	÷14
1 1 (default)	100	÷16

## Absolute Maximum Ratings

NOTE: Stresses beyond those listed under *Absolute Maximum Ratings* may cause permanent damage to the device. These ratings are stress specifications only. Functional operation of product at these conditions or any conditions beyond those listed in the *DC Characteristics* or *AC Characteristics* is not implied. Exposure to absolute maximum rating conditions for extended periods may affect product reliability.

Item	Rating
Supply Voltage, $V_{CC}$	3.63V
Inputs, $V_I$ XTAL_IN Other Inputs	0V to 2V -0.5V to $V_{CC} + 0.5V$
Outputs, $I_O$ Continuous Current Surge Current	50mA 100mA
Package Thermal Impedance, $\theta_{JA}$	39.2°C/W (0 mps)
Storage Temperature, $T_{STG}$	-65°C to 150°C

## DC Electrical Characteristics

**Table 4A. Power Supply DC Characteristics,  $V_{CC} = 3.3V \pm 5\%$ ,  $V_{EE} = 0V$ ,  $T_A = -40^\circ C$  to  $85^\circ C$**

Symbol	Parameter	Test Conditions	Minimum	Typical	Maximum	Units
$V_{CC}$	Power Supply Voltage		3.135	3.3	3.465	V
$I_{EE}$	Power Supply Current				131	mA

**Table 4B. Power Supply DC Characteristics,  $V_{CC} = 2.5V \pm 5\%$ ,  $V_{EE} = 0V$ ,  $T_A = -40^\circ C$  to  $85^\circ C$**

Symbol	Parameter	Test Conditions	Minimum	Typical	Maximum	Units
$V_{CC}$	Power Supply Voltage		2.375	2.5	2.625	V
$I_{EE}$	Power Supply Current				124	mA

**Table 4C. LVCMOS/LVTTL DC Characteristics,  $V_{CC} = 3.3V \pm 5\%$  or  $2.5V \pm 5\%$ ,  $V_{EE} = 0V$ ,  $T_A = -40^\circ C$  to  $85^\circ C$**

Symbol	Parameter	Test Conditions	Minimum	Typical	Maximum	Units
$V_{IH}$	Input High Voltage	$V_{CC} = 3.465V$	2		$V_{CC} + 0.3$	V
		$V_{CC} = 2.625V$	1.7		$V_{CC} + 0.3$	V
$V_{IL}$	Input Low Voltage	$V_{CC} = 3.465V$	-0.3		0.8	V
		$V_{CC} = 2.625V$	-0.3		0.7	V
$I_{IH}$	Input High Current OE, FSEL[1:0]	$V_{CC} = V_{IN} = 3.465V$ or $2.625V$			5	$\mu A$
$I_{IL}$	Input Low Current OE, FSEL[1:0]	$V_{CC} = 3.465V$ or $2.625V$ , $V_{IN} = 0V$	-150			$\mu A$

**Table 4D. LVPECL DC Characteristics,  $V_{CC} = 3.3V \pm 5\%$  or  $2.5V \pm 5\%$ ,  $V_{EE} = 0V$ ,  $T_A = -40^\circ C$  to  $85^\circ C$**

Symbol	Parameter	Test Conditions	Minimum	Typical	Maximum	Units
$V_{OH}$	Output High Voltage; NOTE 1		$V_{CC} - 1.3$		$V_{CC} - 0.8$	V
$V_{OL}$	Output Low Voltage; NOTE 1		$V_{CC} - 2.0$		$V_{CC} - 1.6$	V
$V_{SWING}$	Peak-to-Peak Output Voltage Swing		0.6		1.0	V

NOTE 1: Outputs termination with  $50\Omega$  to  $V_{CC} - 2V$ .

**Table 5. Crystal Characteristics**

Parameter	Test Conditions	Minimum	Typical	Maximum	Units
Mode of Oscillation		Fundamental			
Frequency		20		25	MHz
Equivalent Series Resistance (ESR)				50	$\Omega$
Shunt Capacitance				7	pF

## AC Electrical Characteristics

**Table 6A. AC Characteristics,  $V_{CC} = 3.3V \pm 5\%$ ,  $V_{EE} = 0V$ ,  $T_A = -40^\circ C$  to  $85^\circ C$**

Symbol	Parameter	Test Conditions	Minimum	Typical	Maximum	Units
$f_{MAX}$	Output Frequency		100		156.25	MHz
$f_{jit}(\emptyset)$	RMS Phase Jitter (Random); NOTE 1	156.25MHz, Integration Range: 12kHz – 20MHz		0.348	0.5	ps
		150MHz, Integration Range: 12kHz – 20MHz		0.318	0.5	ps
		125MHz, Integration Range: 12kHz – 20MHz		0.314	0.5	ps
		100MHz, Integration Range: 12kHz – 20MHz		0.323	0.5	ps
$f_{jit}(cc)$	Cycle-to-Cycle Jitter; NOTE 2				10	ps
$t_R / t_F$	Output Rise/Fall Time	20% to 80%	100		350	ps
odc	Output Duty Cycle		49		51	%

NOTE: Electrical parameters are guaranteed over the specified ambient operating temperature range, which is established when the device is mounted in a test socket with maintained transverse airflow greater than 500 lpm. The device will meet specifications after thermal equilibrium has been reached under these conditions.

NOTE: Characterized using a 25MHz, 12pF resonant crystal.

NOTE 1: Please refer to the Phase Noise plots.

NOTE 2: This parameter is defined in accordance with JEDEC Standard 65.

**Table 6B. AC Characteristics,  $V_{CC} = 2.5V \pm 5\%$ ,  $V_{EE} = 0V$ ,  $T_A = -40^\circ C$  to  $85^\circ C$**

Symbol	Parameter	Test Conditions	Minimum	Typical	Maximum	Units
$f_{MAX}$	Output Frequency		100		156.25	MHz
$f_{jit}(\emptyset)$	RMS Phase Jitter (Random)	156.25MHz, Integration Range: 12kHz – 20MHz		0.353	0.5	ps
		150MHz, Integration Range: 12kHz – 20MHz		0.322	0.5	ps
		125MHz, Integration Range: 12kHz – 20MHz		0.319	0.5	ps
		100MHz, Integration Range: 12kHz – 20MHz		0.326	0.5	ps
$f_{jit}(cc)$	Cycle-to-Cycle Jitter; NOTE 1				15	ps
$t_R / t_F$	Output Rise/Fall Time	20% to 80%	100		350	ps
odc	Output Duty Cycle		49		51	%

NOTE: Electrical parameters are guaranteed over the specified ambient operating temperature range, which is established when the device is mounted in a test socket with maintained transverse airflow greater than 500 lpm. The device will meet specifications after thermal equilibrium has been reached under these conditions.

NOTE: Characterized using a 25MHz, 12pF resonant crystal.

NOTE 1: This parameter is defined in accordance with JEDEC Standard 65.

Typical Phase Noise at 100MHz @ 3.3V

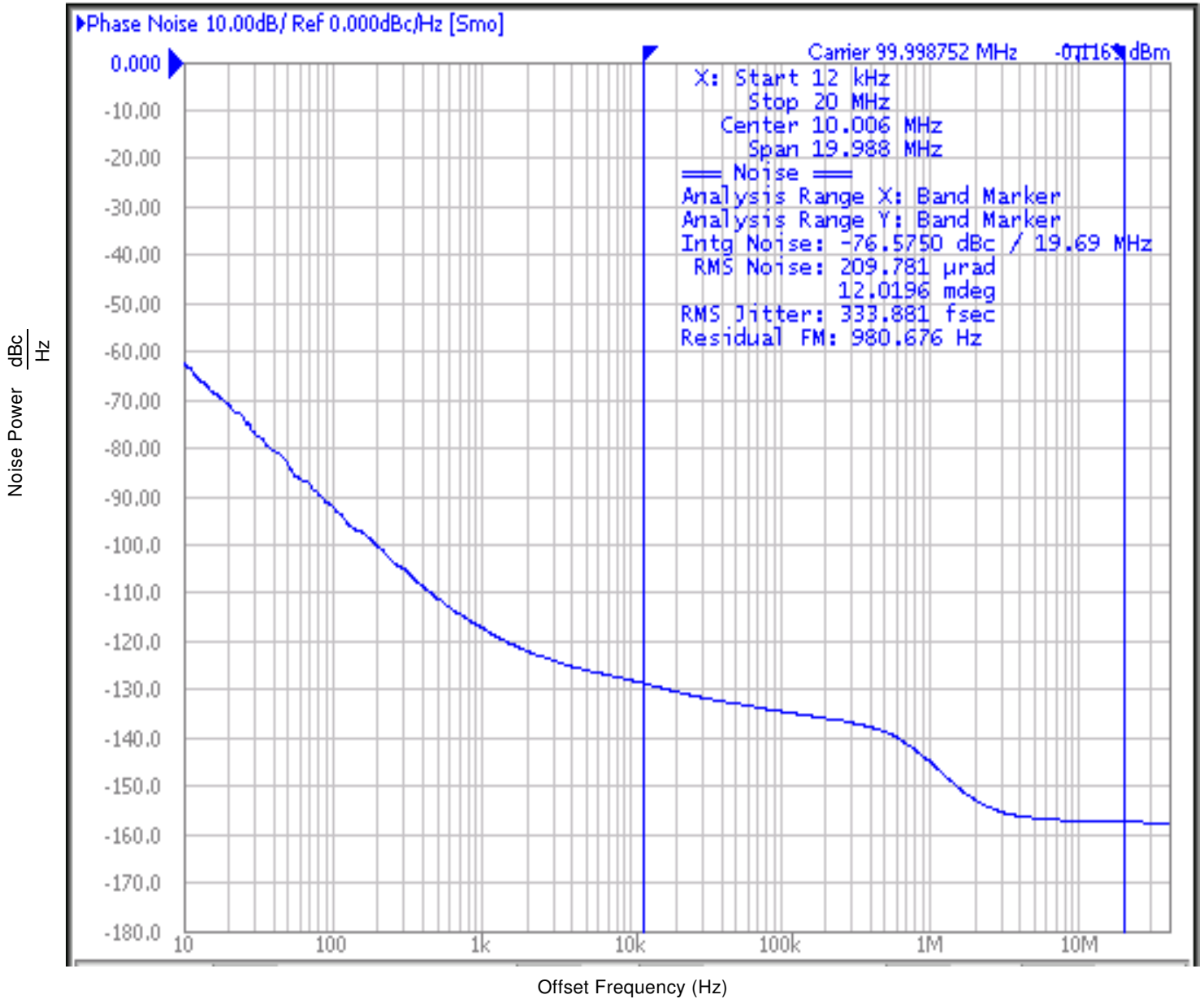

Typical Phase Noise at 156.25MHz @ 3.3V

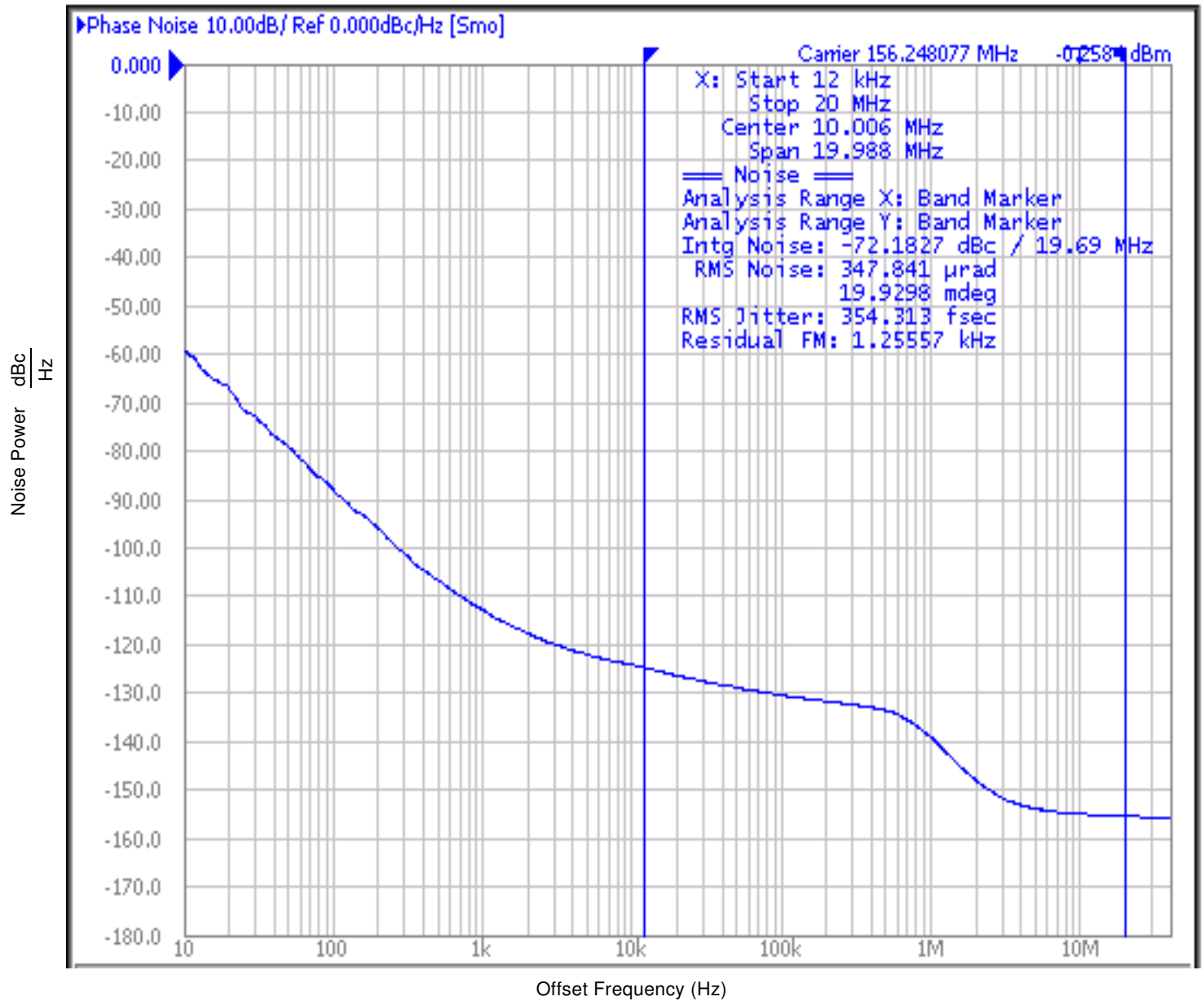

## Parameter Measurement Information

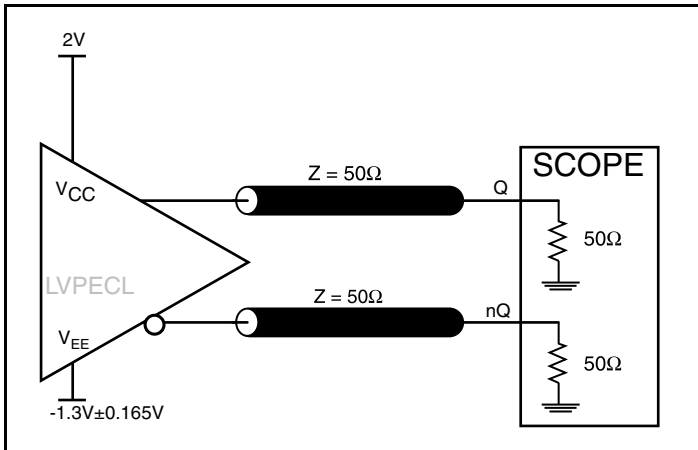

3.3V LVPECL Output Load AC Test Circuit

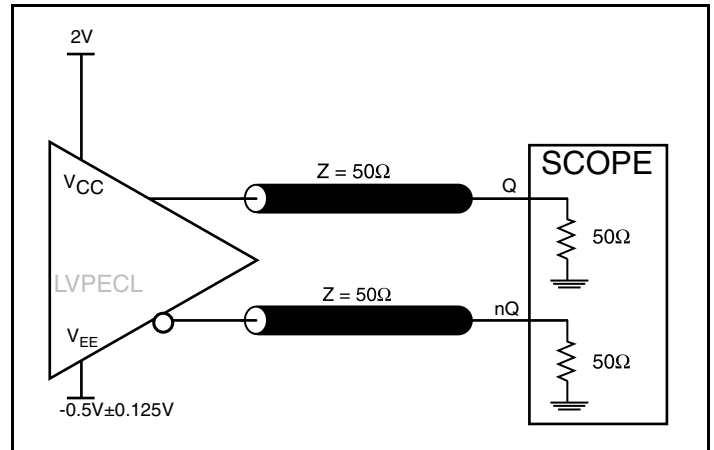

2.5V LVPECL Output Load AC Test Circuit

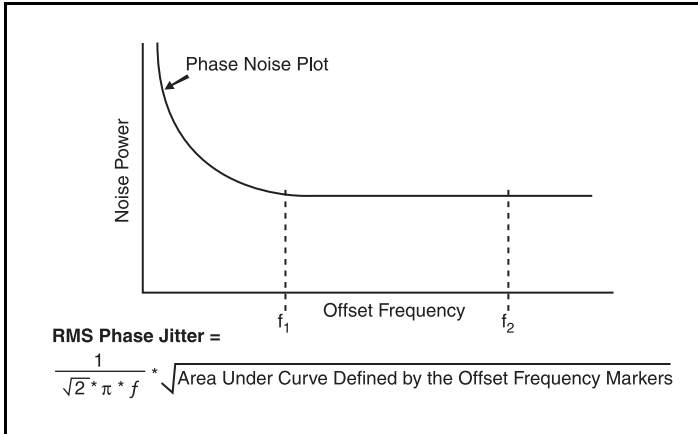

RMS Phase Jitter

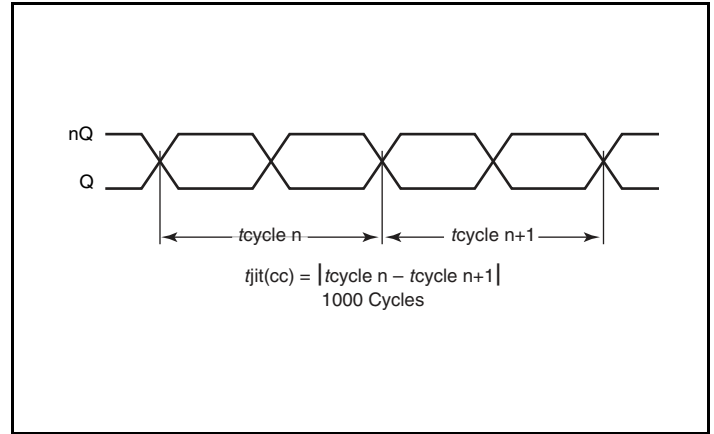

Cycle-to-Cycle Jitter

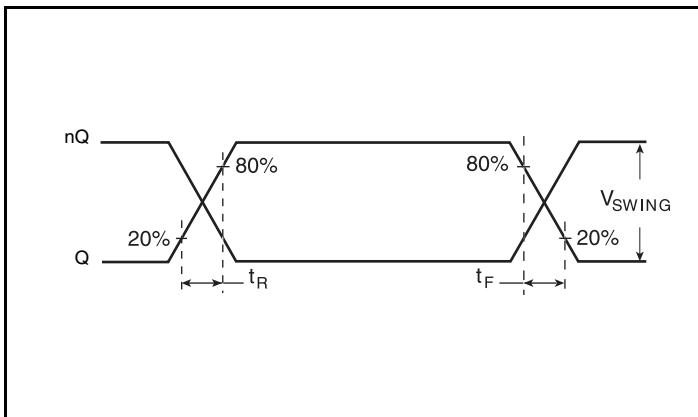

Output Rise/Fall Time

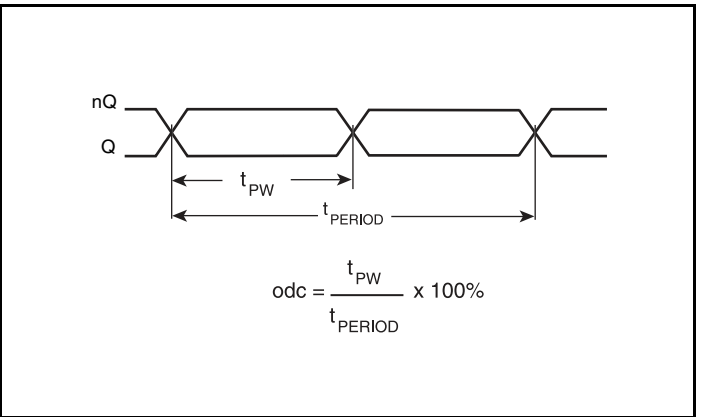

Output Duty Cycle/Pulse Width/Period



## Applications Information

### VFQFN EPAD Thermal Release Path

In order to maximize both the removal of heat from the package and the electrical performance, a land pattern must be incorporated on the Printed Circuit Board (PCB) within the footprint of the package corresponding to the exposed metal pad or exposed heat slug on the package, as shown in *Figure 1*. The solderable area on the PCB, as defined by the solder mask, should be at least the same size/shape as the exposed pad/slug area on the package to maximize the thermal/electrical performance. Sufficient clearance should be designed on the PCB between the outer edges of the land pattern and the inner edges of pad pattern for the leads to avoid any shorts.

While the land pattern on the PCB provides a means of heat transfer and electrical grounding from the package to the board through a solder joint, thermal vias are necessary to effectively conduct from the surface of the PCB to the ground plane(s). The land pattern must be connected to ground through these vias. The vias act as “heat pipes”. The number of vias (i.e. “heat pipes”) are application specific

and dependent upon the package power dissipation as well as electrical conductivity requirements. Thus, thermal and electrical analysis and/or testing are recommended to determine the minimum number needed. Maximum thermal and electrical performance is achieved when an array of vias is incorporated in the land pattern. It is recommended to use as many vias connected to ground as possible. It is also recommended that the via diameter should be 12 to 13mils (0.30 to 0.33mm) with 1oz copper via barrel plating. This is desirable to avoid any solder wicking inside the via during the soldering process which may result in voids in solder between the exposed pad/slug and the thermal land. Precautions should be taken to eliminate any solder voids between the exposed heat slug and the land pattern. Note: These recommendations are to be used as a guideline only. For further information, please refer to the Application Note on the Surface Mount Assembly of Amkor’s Thermally /Electrically Enhance Leadframe Base Package, Amkor Technology.

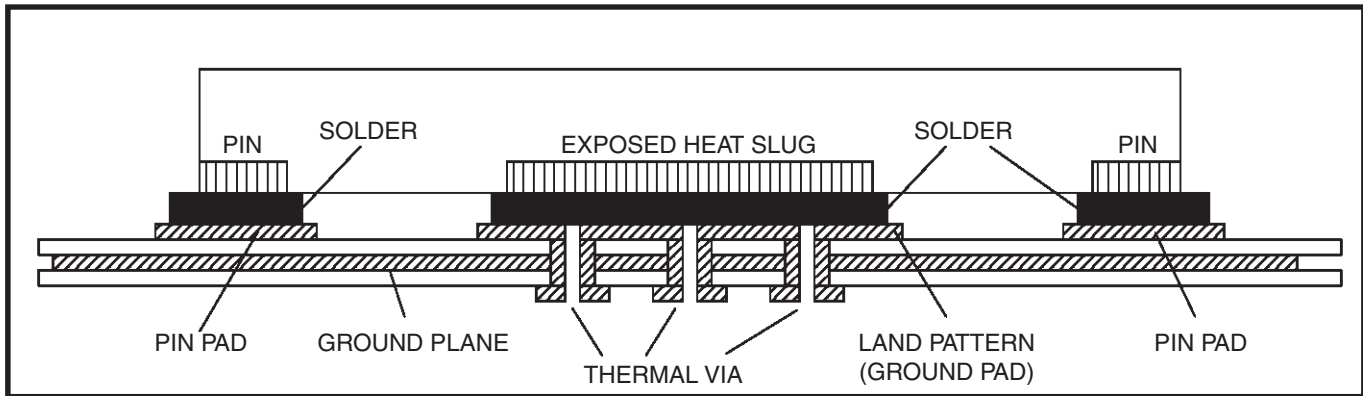

Figure 1. P.C. Assembly for Exposed Pad Thermal Release Path – Side View (drawing not to scale)

### Crystal Input Interface

The 83PN1561 has been characterized with 12pF parallel resonant crystals. The capacitor values shown in *Figure 2A* below were determined using a 25MHz, 12pF parallel resonant crystal and were

chosen to minimize the ppm error. Other parallel resonant crystal’s values can be used. For example, a crystal with a  $C_L = 18\text{pF}$  can be used, but would require the tuning capacitors to be adjusted.

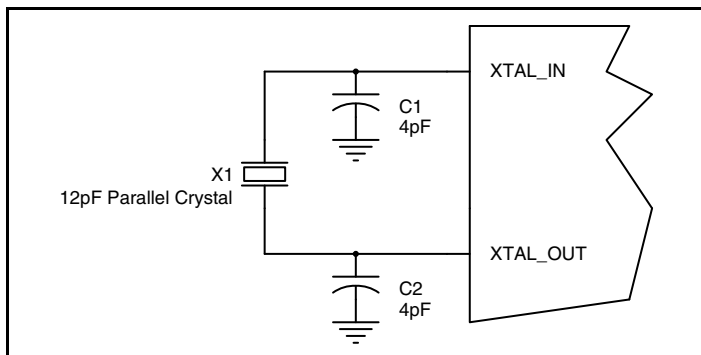

Figure 2A. Crystal Input Interface, using 12pF crystal

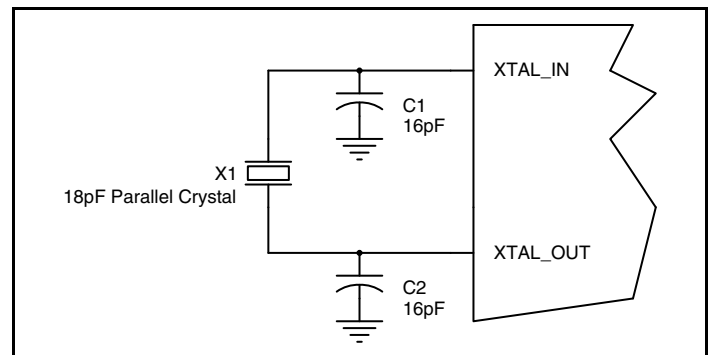

Figure 2B. Crystal Input Interface, using 18pF crystal

## Overdriving the XTAL Interface

The XTAL\_IN input can be overdriven by an LVCMOS driver or by one side of a differential driver through an AC coupling capacitor. The XTAL\_OUT pin can be left floating. The amplitude of the input signal should be between 500mV and 1.8V and the slew rate should not be less than 0.2V/nS. For 3.3V LVCMOS inputs, the amplitude must be reduced from full swing to at least half the swing in order to prevent signal interference with the power rail and to reduce internal noise. *Figure 3A* shows an example of the interface diagram for a high speed 3.3V LVCMOS driver. This configuration requires that the sum of the output impedance of the driver ( $R_o$ ) and the series resistance ( $R_s$ ) equals the transmission line impedance. In addition, matched termination at the crystal input will attenuate the signal in half. This

can be done in one of two ways. First,  $R_1$  and  $R_2$  in parallel should equal the transmission line impedance. For most 50Ω applications,  $R_1$  and  $R_2$  can be 100Ω. This can also be accomplished by removing  $R_1$  and changing  $R_2$  to 50Ω. The values of the resistors can be increased to reduce the loading for a slower and weaker LVCMOS driver. *Figure 3B* shows an example of the interface diagram for an LVPECL driver. This is a standard LVPECL termination with one side of the driver feeding the XTAL\_IN input. It is recommended that all components in the schematics be placed in the layout. Though some components might not be used, they can be utilized for debugging purposes. The datasheet specifications are characterized and guaranteed by using a quartz crystal as the input.

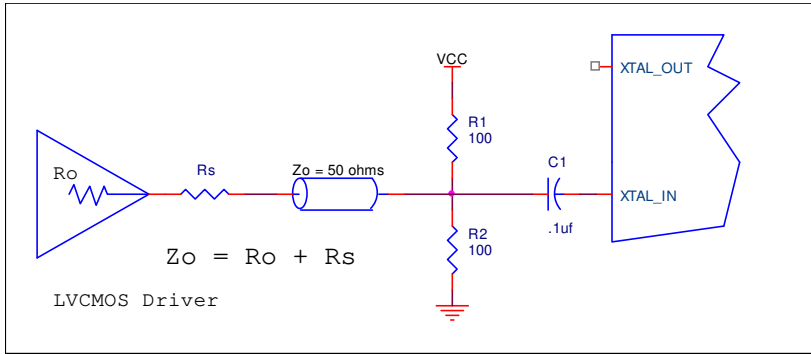

Figure 3A. General Diagram for LVCMOS Driver to XTAL Input Interface

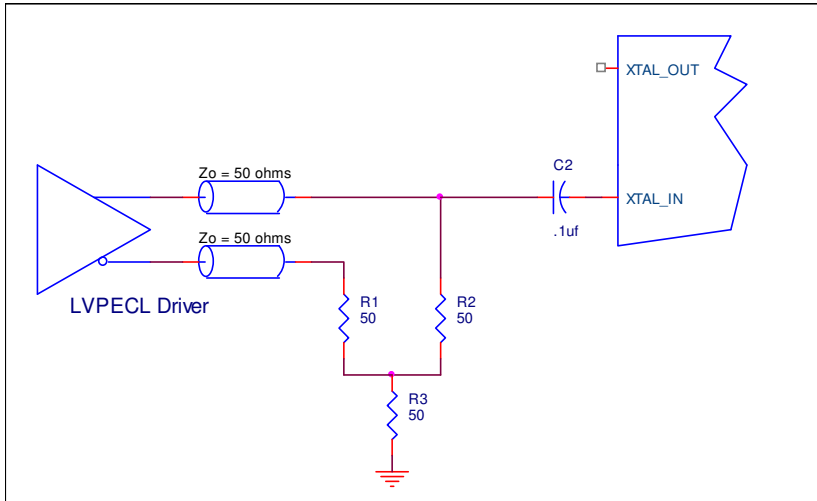

Figure 3B. General Diagram for LVPECL Driver to XTAL Input Interface

## Recommendations for Unused Input Pins

### Inputs:

#### LVC MOS Control Pins

All control pins have internal pullups; additional resistance is not required but can be added for additional protection. A 1kΩ resistor can be used.

### Termination for 3.3V LVPECL Outputs

The clock layout topology shown below is a typical termination for LVPECL outputs. The two different layouts mentioned are recommended only as guidelines.

The differential outputs are low impedance follower outputs that generate ECL/LVPECL compatible outputs. Therefore, terminating resistors (DC current path to ground) or current sources must be used for functionality. These outputs are designed to drive 50Ω

transmission lines. Matched impedance techniques should be used to maximize operating frequency and minimize signal distortion. *Figures 4A and 4B* show two different layouts which are recommended only as guidelines. Other suitable clock layouts may exist and it would be recommended that the board designers simulate to guarantee compatibility across all printed circuit and clock component process variations.

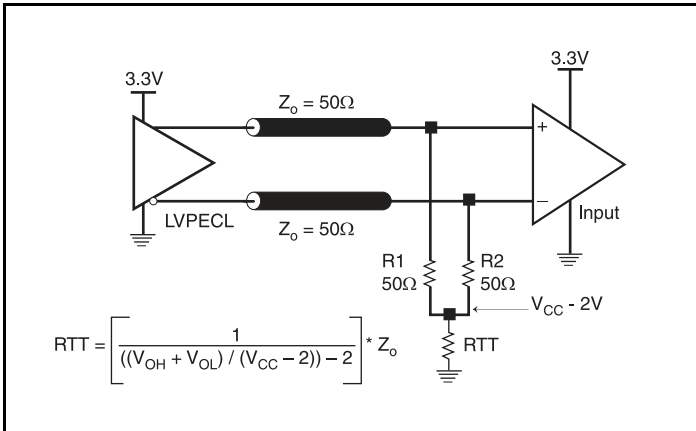

Figure 4A. 3.3V LVPECL Output Termination

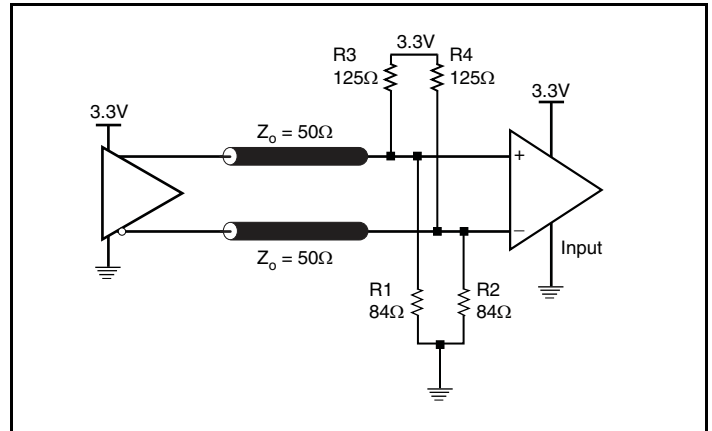

Figure 4B. 3.3V LVPECL Output Termination

## Termination for 2.5V LVPECL Outputs

Figure 5A and Figure 5B show examples of termination for 2.5V LVPECL driver. These terminations are equivalent to terminating 50Ω to  $V_{CC} - 2V$ . For  $V_{CC} = 2.5V$ , the  $V_{CC} - 2V$  is very close to ground

level. The R3 in Figure 5B can be eliminated and the termination is shown in Figure 5C.

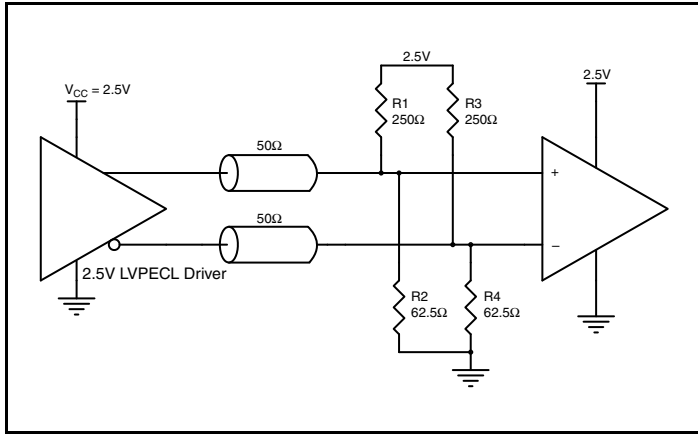

Figure 5A. 2.5V LVPECL Driver Termination Example

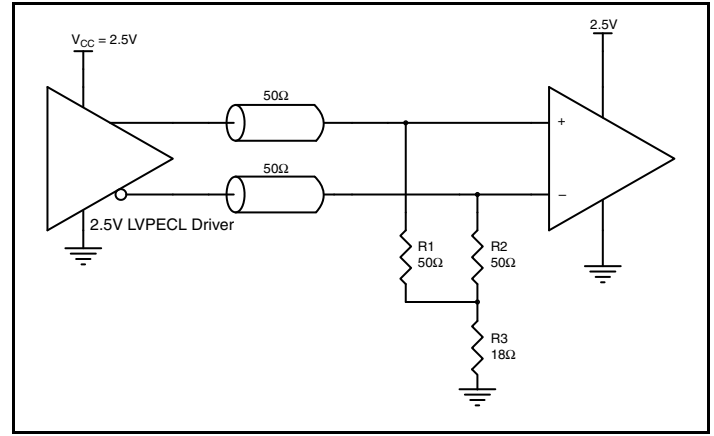

Figure 5B. 2.5V LVPECL Driver Termination Example

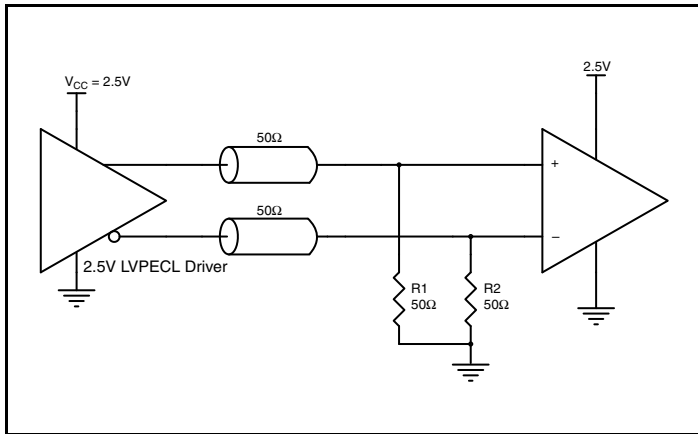

Figure 5C. 2.5V LVPECL Driver Termination Example

## Power Considerations

This section provides information on power dissipation and junction temperature for the 83PN156I. Equations and example calculations are also provided.

### 1. Power Dissipation.

The total power dissipation for the 83PN156I is the sum of the core power plus the power dissipated in the load(s). The following is the power dissipation for  $V_{CC} = 3.3V + 5\% = 3.465V$ , which gives worst case results.

NOTE: Please refer to Section 3 for details on calculating power dissipated in the load.

- Power (core)<sub>MAX</sub> =  $V_{CC\_MAX} * I_{EE\_MAX} = 3.465V * 131mA = \mathbf{453.915mW}$
- Power (outputs)<sub>MAX</sub> = **32mW/Loaded Output pair**

**Total Power**<sub>MAX</sub> (3.3V, with all outputs switching) =  $453.915mW + 32mW = \mathbf{485.915mW}$

### 2. Junction Temperature.

Junction temperature,  $T_j$ , is the temperature at the junction of the bond wire and bond pad directly affects the reliability of the device. The maximum recommended junction temperature is 125°C. Limiting the internal transistor junction temperature,  $T_j$ , to 125°C ensures that the bond wire and bond pad temperature remains below 125°C.

The equation for  $T_j$  is as follows:  $T_j = \theta_{JA} * Pd\_total + T_A$

$T_j$  = Junction Temperature

$\theta_{JA}$  = Junction-to-Ambient Thermal Resistance

$Pd\_total$  = Total Device Power Dissipation (example calculation is in section 1 above)

$T_A$  = Ambient Temperature

In order to calculate junction temperature, the appropriate junction-to-ambient thermal resistance  $\theta_{JA}$  must be used. Assuming no air flow and a multi-layer board, the appropriate value is 39.2°C/W per Table 7 below.

Therefore,  $T_j$  for an ambient temperature of 85°C with all outputs switching is:

$$85^\circ\text{C} + 0.486\text{W} * 39.2^\circ\text{C/W} = 104.1^\circ\text{C}. \text{ This is below the limit of } 125^\circ\text{C}.$$

This calculation is only an example.  $T_j$  will obviously vary depending on the number of loaded outputs, supply voltage, air flow and the type of board (multi-layer).

**Table 7. Thermal Resistance  $\theta_{JA}$  for 10 Lead VFQFN, Forced Convection**

$\theta_{JA}$ vs. Air Flow	
Meters per Second	<b>0</b>
Multi-Layer PCB, JEDEC Standard Test Boards	39.2°C/W

### 3. Calculations and Equations.

The purpose of this section is to calculate the power dissipation for the LVPECL output pair.

LVPECL output driver circuit and termination are shown in *Figure 6*.

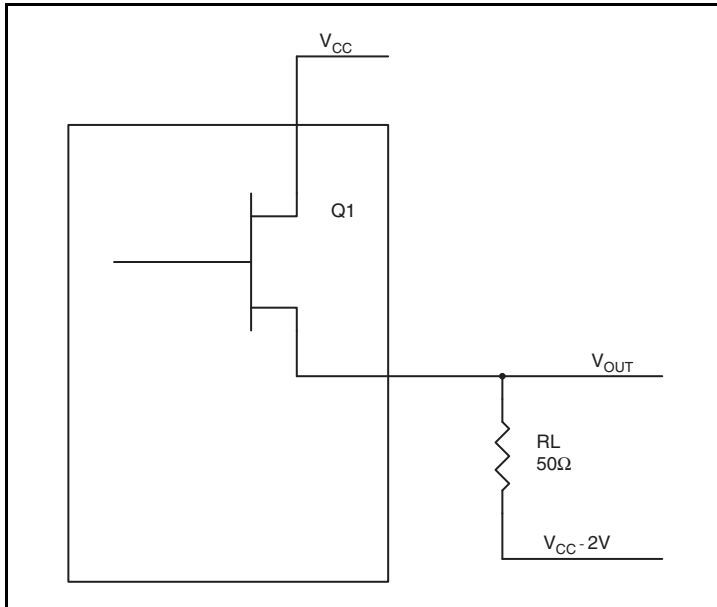

**Figure 6. LVPECL Driver Circuit and Termination**

To calculate worst case power dissipation into the load, use the following equations which assume a 50Ω load, and a termination voltage of  $V_{CC} - 2V$ .

- For logic high,  $V_{OUT} = V_{OH\_MAX} = V_{CC\_MAX} - 0.8V$   
 $(V_{CC\_MAX} - V_{OH\_MAX}) = 0.8V$
- For logic low,  $V_{OUT} = V_{OL\_MAX} = V_{CC\_MAX} - 1.6V$   
 $(V_{CC\_MAX} - V_{OL\_MAX}) = 1.6V$

$Pd\_H$  is power dissipation when the output drives high.

$Pd\_L$  is the power dissipation when the output drives low.

$$Pd\_H = [(V_{OH\_MAX} - (V_{CC\_MAX} - 2V))/R_L] * (V_{CC\_MAX} - V_{OH\_MAX}) = [(2V - (V_{CC\_MAX} - V_{OH\_MAX}))/R_L] * (V_{CC\_MAX} - V_{OH\_MAX}) = [(2V - 0.8V)/50\Omega] * 0.8V = \mathbf{19.2mW}$$

$$Pd\_L = [(V_{OL\_MAX} - (V_{CC\_MAX} - 2V))/R_L] * (V_{CC\_MAX} - V_{OL\_MAX}) = [(2V - (V_{CC\_MAX} - V_{OL\_MAX}))/R_L] * (V_{CC\_MAX} - V_{OL\_MAX}) = [(2V - 1.6V)/50\Omega] * 1.6V = \mathbf{12.82mW}$$

$$\text{Total Power Dissipation per output pair} = Pd\_H + Pd\_L = \mathbf{32mW}$$

## Reliability Information

**Table 8.  $\theta_{JA}$  vs. Air Flow Table for a 10 Lead VFQFN**

$\theta_{JA}$ vs. Air Flow	
Meters per Second	0
Multi-Layer PCB, JEDEC Standard Test Boards	39.2°C/W

## Transistor Count

The transistor count for 83PN156I is: 24,932

## Package Dimensions

**Table 9. Package Dimensions for 10-Lead VFQFN**

VNJR-1			
All Dimensions in Millimeters			
Symbol	Minimum	Nominal	Maximum
<b>N</b>	10		
<b>A</b>	0.80	0.90	1.00
<b>A1</b>	0	0.02	0.05
<b>b1</b>	0.35	0.40	0.45
<b>b2</b>	1.35	1.40	1.45
<b>D</b>	5.00 Basic		
<b>D2</b>	1.55	1.70	1.80
<b>E</b>	7.00 Basic		
<b>E2</b>	3.55	3.70	3.80
<b>e1</b>	1.0		
<b>e2</b>	2.54		
<b>L1</b>	0.45	0.55	0.65
<b>L2</b>	1.0	1.10	1.20
<b>N</b>	10		
<b>N<sub>D</sub></b>	2		
<b>N<sub>E</sub></b>	3		
<b>aaa</b>	0.15		
<b>bbb</b>	0.10		
<b>ccc</b>	0.10		

# Package Outline

## Package Outline - K Suffix for 10-Lead VFQFN

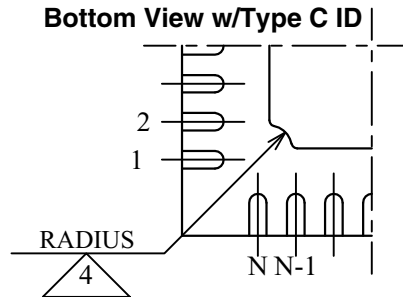
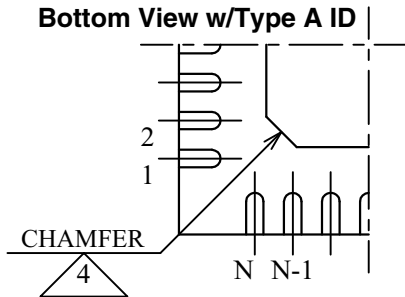
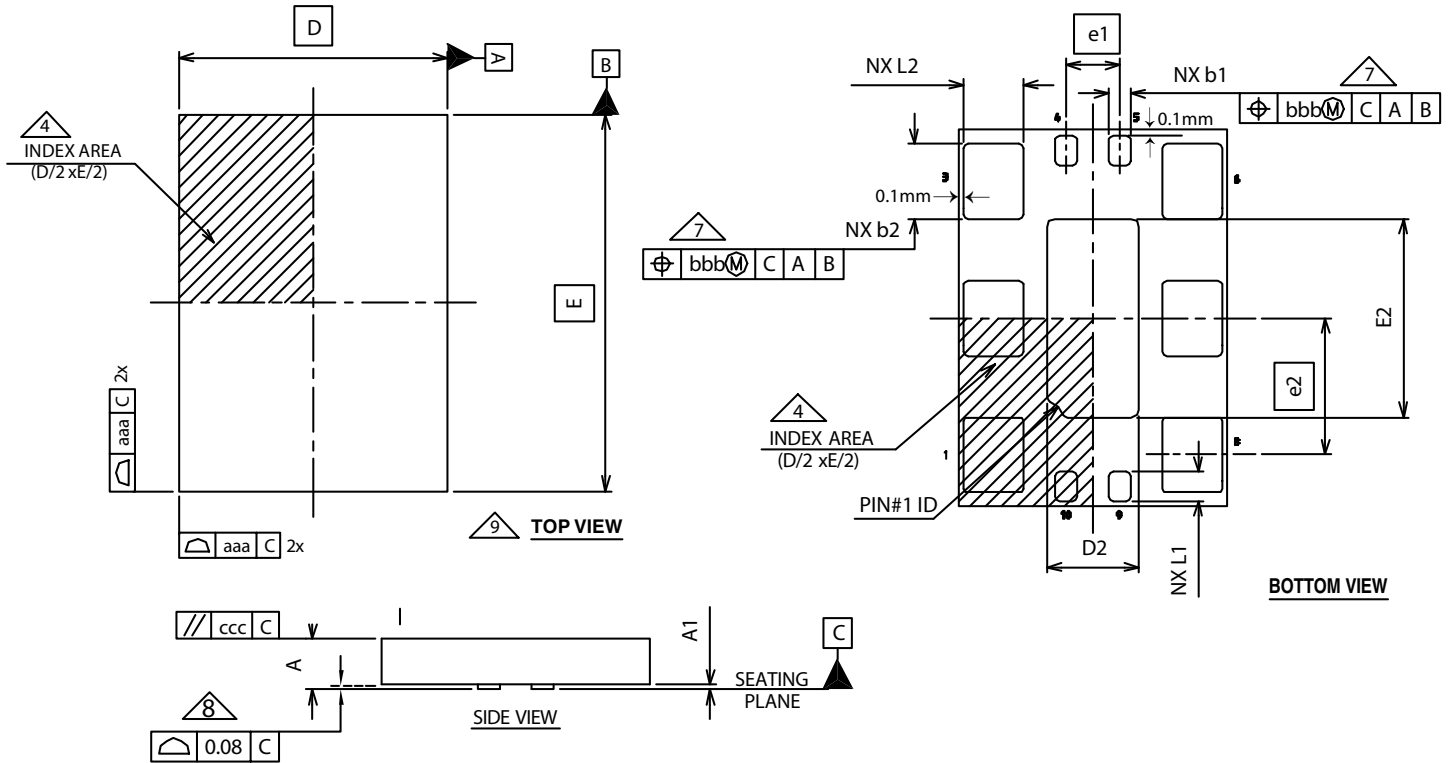

- There are 2 methods of indicating pin 1 corner at the back of the VFQFN package:
1. Type A: Chamfer on the paddle (near pin 1)
  2. Type C: Mouse bite on the paddle (near pin 1)

NOTE: The following package mechanical drawing is a generic drawing that applies to any pin count VFQFN package. This drawing is not intended to convey the actual pin count or pin layout of this device. The pin count and pinout are shown on the front page. The package dimensions are in Table 9.



## Ordering Information

Table 10. Ordering Information

Part/Order Number	Marking	Package	Shipping Packaging	Temperature
83PN156DKILF	ICS3PN156DIL	“Lead-Free” 10 Lead VFQFN	Tray	-40°C to 85°C
83PN156DKILFT	ICS3PN156DIL	“Lead-Free” 10Lead VFQFN	Tape & Reel	-40°C to 85°C

## Revision History Sheet

Rev	Table	Page	Description of Change	Date
A		3 10	Absolute Maximum Ratings - corrected supply voltage to 3.63V. Updated <i>Overdriving the XTAL Interface</i> application note.	4/25/11
A	T10	17	Ordering Information - removed quantity from tape and reel. Deleted LF note below table. Removed ICS from part number where needed. Updated header and footer.	3/4/16



## IMPORTANT NOTICE AND DISCLAIMER

RENESAS ELECTRONICS CORPORATION AND ITS SUBSIDIARIES (“RENESAS”) PROVIDES TECHNICAL SPECIFICATIONS AND RELIABILITY DATA (INCLUDING DATASHEETS), DESIGN RESOURCES (INCLUDING REFERENCE DESIGNS), APPLICATION OR OTHER DESIGN ADVICE, WEB TOOLS, SAFETY INFORMATION, AND OTHER RESOURCES “AS IS” AND WITH ALL FAULTS, AND DISCLAIMS ALL WARRANTIES, EXPRESS OR IMPLIED, INCLUDING, WITHOUT LIMITATION, ANY IMPLIED WARRANTIES OF MERCHANTABILITY, FITNESS FOR A PARTICULAR PURPOSE, OR NON-INFRINGEMENT OF THIRD PARTY INTELLECTUAL PROPERTY RIGHTS.

These resources are intended for developers skilled in the art designing with Renesas products. You are solely responsible for (1) selecting the appropriate products for your application, (2) designing, validating, and testing your application, and (3) ensuring your application meets applicable standards, and any other safety, security, or other requirements. These resources are subject to change without notice. Renesas grants you permission to use these resources only for development of an application that uses Renesas products. Other reproduction or use of these resources is strictly prohibited. No license is granted to any other Renesas intellectual property or to any third party intellectual property. Renesas disclaims responsibility for, and you will fully indemnify Renesas and its representatives against, any claims, damages, costs, losses, or liabilities arising out of your use of these resources. Renesas' products are provided only subject to Renesas' Terms and Conditions of Sale or other applicable terms agreed to in writing. No use of any Renesas resources expands or otherwise alters any applicable warranties or warranty disclaimers for these products.

(Disclaimer Rev.1.0 Mar 2020)

### Corporate Headquarters

TOYOSU FORESIA, 3-2-24 Toyosu,  
Koto-ku, Tokyo 135-0061, Japan  
[www.renesas.com](http://www.renesas.com)

### Contact Information

For further information on a product, technology, the most up-to-date version of a document, or your nearest sales office, please visit:  
[www.renesas.com/contact/](http://www.renesas.com/contact/)

### Trademarks

Renesas and the Renesas logo are trademarks of Renesas Electronics Corporation. All trademarks and registered trademarks are the property of their respective owners.