

# Customer Information Sheet

DRAWING No.: M50-315XX42

SHEET 2 OF 2

IF IN DOUBT - ASK

©

NOT TO SCALE

THIRD ANGLE PROJECTION

ALL DIMENSIONS IN mm

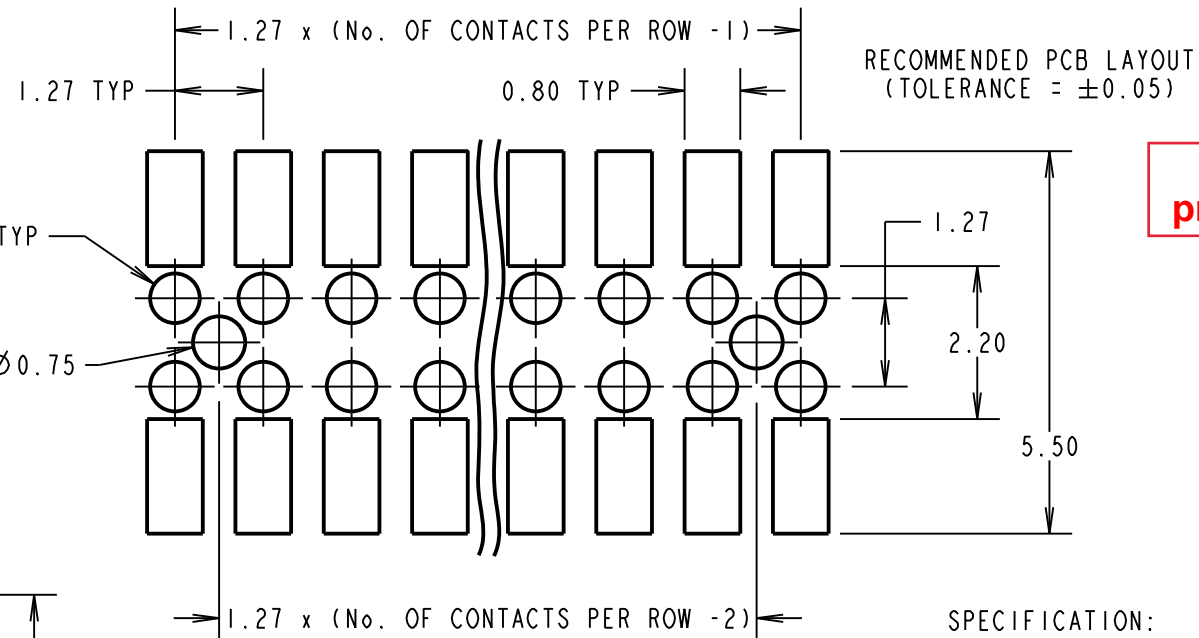
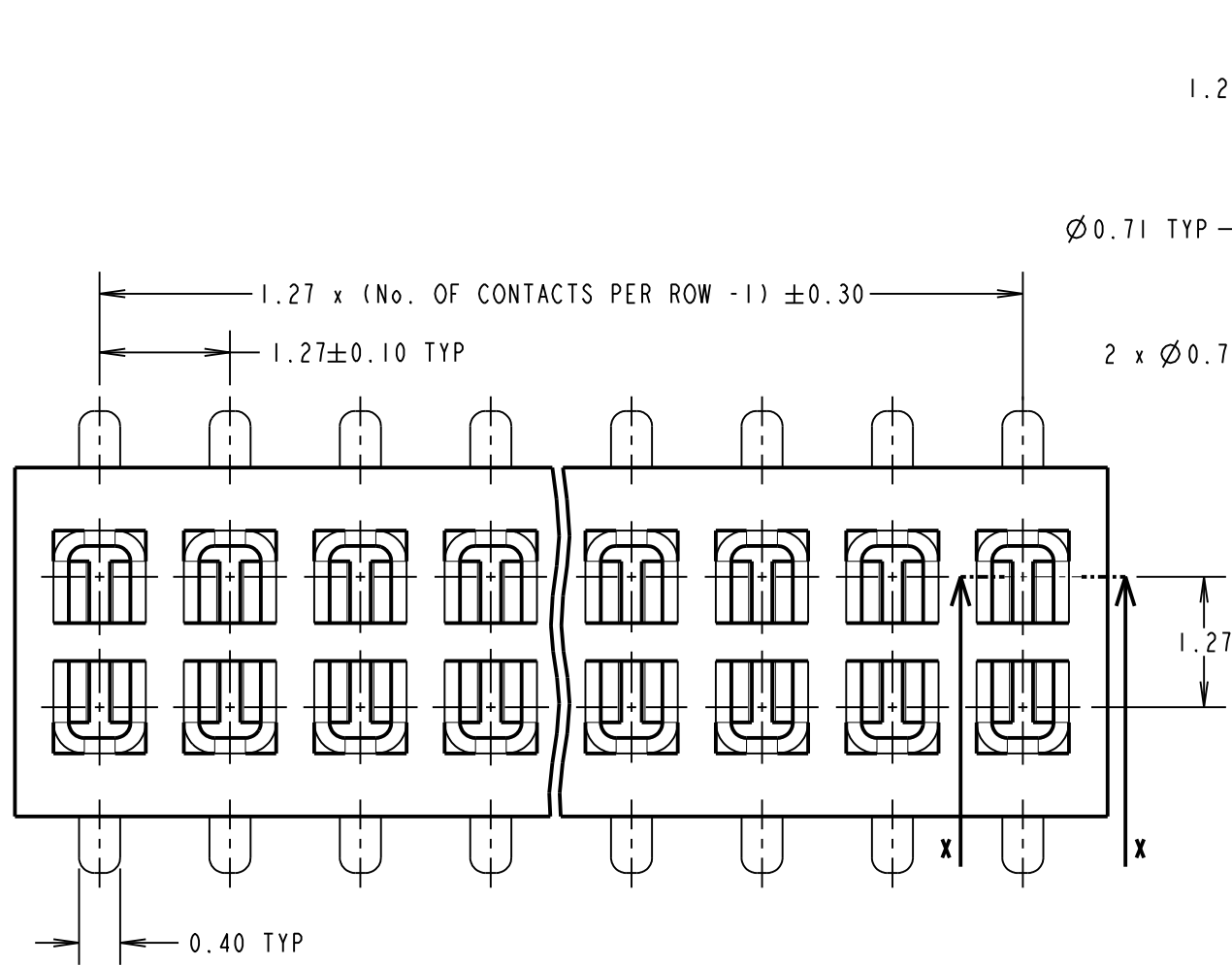

**Active products:**

- M50-3150342
- M50-3150542
- M50-3150642
- M50-3150842
- M50-3151042
- M50-3151242
- M50-3151542
- M50-3152042
- M50-3152542

**OBSOLETE**  
All other size/finish combinations not listed

ORDER CODE

**M50-315XX42**

No. OF CONTACTS PER ROW: \_\_\_\_\_  
03 TO 40

FINISH: \_\_\_\_\_  
42 = GOLD FLASH + 100% TIN OVER NICKEL

**SPECIFICATION:**

**MATERIAL:**  
MOULDING = NYLON-6T, UL94V-0, BLACK  
**CONTACTS = PHOSPHOR BRONZE**  
**FINISH:**  
CONTACTS = 1.27µ NICKEL ALL OVER,  
GOLD FLASH ON CONTACT AREA,  
2.54µ 100% TIN ON TAILS

**ELECTRICAL:**  
CURRENT RATING = 1A  
CONTACT RESISTANCE = 20mΩ MAX  
INSULATION RESISTANCE = 1000MΩ MIN  
DIELECTRIC WITHSTANDING = 500V AC FOR ONE MINUTE

**MECHANICAL:**  
DURABILITY = 300 CYCLES MIN  
INSERTION FORCE = 1.5N MAX PER CONTACT  
WITHDRAWAL FORCE = 0.2N MIN PER CONTACT

**ENVIRONMENTAL:**  
TEMPERATURE RANGE = -40°C TO +105°C

**PACKING:**  
TUBE  
FOR COMPLETE SPECIFICATION, SEE COMPONENT SPECIFICATION C029XX (LATEST ISSUE)

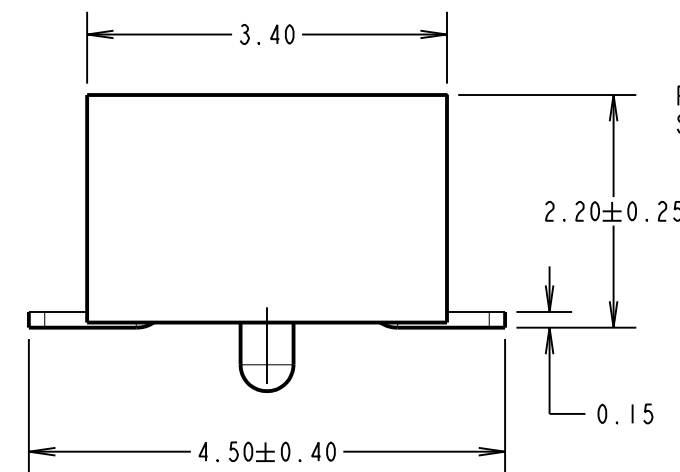
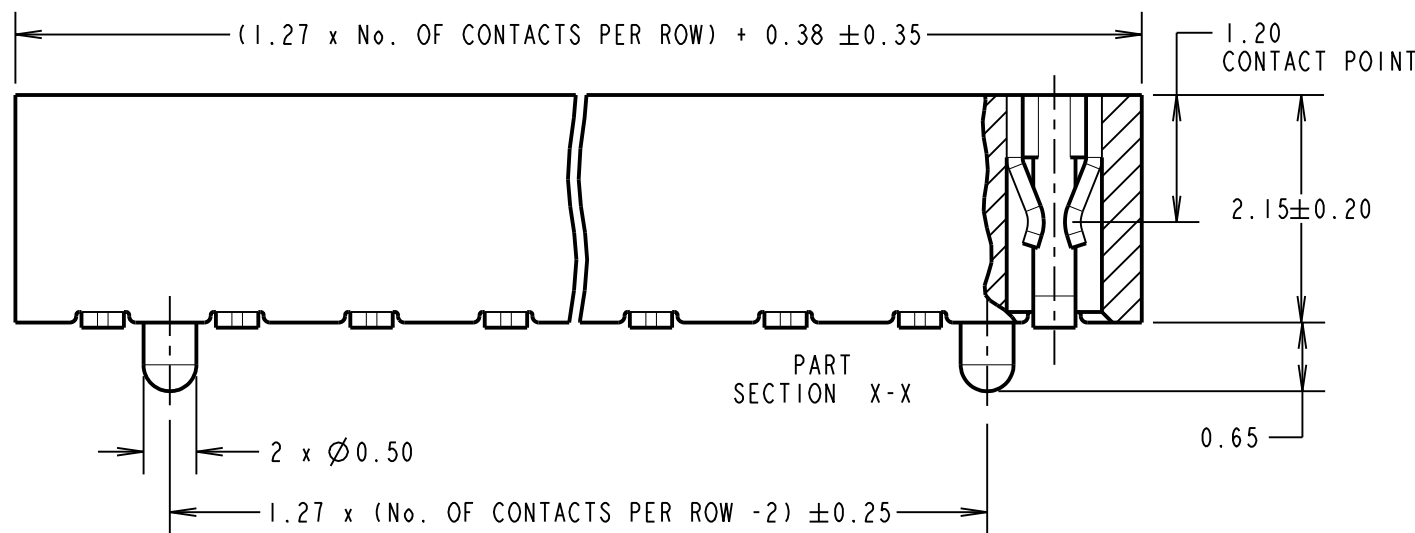

NOTE:  
1. ALL TOLERANCES ARE ±0.15 UNLESS OTHERWISE STATED.

**HARWIN**

www.harwin.com  
technical@harwin.com

THIS DRAWING AND ANY INFORMATION OR DESCRIPTIVE MATTER SET OUT HEREON ARE CONFIDENTIAL AND COPYRIGHT PROPERTY OF THE HARWIN GROUP AND MUST NOT BE DISCLOSED, LOANED, COPIED OR USED FOR MANUFACTURING, TENDERING OR FOR ANY OTHER PURPOSE WITHOUT THEIR WRITTEN PERMISSION.

**TOLERANCES**  
X = ±1mm  
X.X = ±0.50mm  
X.XX = ±0.10mm  
X.XXX = ±0.01mm  
ANGLES = ±5°  
UNLESS STATED

**MATERIAL:**  
SEE ABOVE  
**FINISH:**  
SEE ABOVE  
**S/AREA:**  
mm<sup>2</sup>

**TITLE:**  
1.27mm PITCH DIL SMT VERT.  
LOW-PROFILE SOCKET ASSY

**DRAWING NUMBER:**  
**M50-315XX42**

MSP	16	08.08.16	13112
NAME	ISS.	DATE	C/NOTE
APPROVED:		M. PERREN	
CHECKED:		S. BENNETT	
DRAWN:		W. J. BOURNE	
CUSTOMER REF.:			
ASSEMBLY DRG:			