

74F352 Dual 4-Input Multiplexer

General Description

The 'F352 is a very high-speed dual 4-input multiplexer with common Select inputs and individual Enable inputs for each section. It can select two bits of data from four sources. The two buffered outputs present data in the inverted (complementary) form. The 'F352 is the functional equivalent of the 'F153 except with inverted outputs.

Features

- Inverted version of 'F153
- Separate enables for each multiplexer
- Input clamp diode limits high speed termination effects

Ordering Code: See Section 11

Commercial	Package Number	Package Description
74F352PC	N16E	16 Lead (0.300" Wide) Molded Dual-in-Line
74F352SJ (Note 1)	M16D	16 Lead (0.300" Wide) Molded Small Outline, JEDEC

Note 1: Devices also available in 13" reel. Use suffix = SJX

Logic Symbols

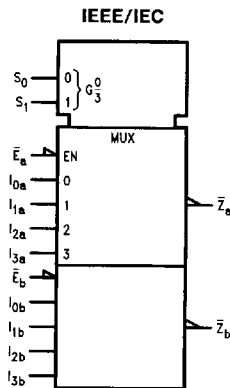
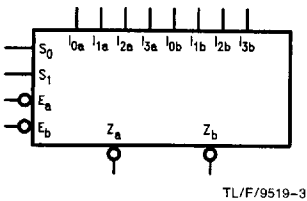

Connection Diagram

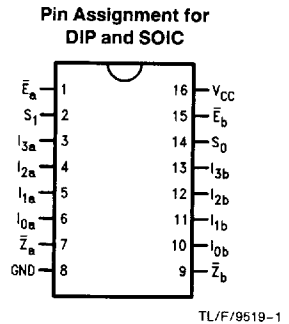

Unit Loading/Fan Out: See Section 2 for U.L. definitions

Pin Names	Description	74F	
		U.L. HIGH/LOW	Input I_{IH}/I_{IL} Output I_{OH}/I_{OL}
$I_{0a}-I_{3a}$	Side A Data Inputs	1.0/1.0	20 μ A/ -0.6 mA
$I_{0b}-I_{3b}$	Side B Data Inputs	1.0/1.0	20 μ A/ -0.6 mA
S_0-S_1	Common Select Inputs	1.0/1.0	20 μ A/ -0.6 mA
\bar{E}_a	Side A Enable Input (Active LOW)	1.0/1.0	20 μ A/ -0.6 mA
\bar{E}_b	Side B Enable Input (Active LOW)	1.0/1.0	20 μ A/ -0.6 mA
\bar{Z}_a, \bar{Z}_b	Multiplexer Outputs (Inverted)	50/33.3	-1 mA/20 mA

Functional Description

The 'F352 is a dual 4-input multiplexer. It selects two bits of data from up to four sources under the control of the common Select inputs (S_0, S_1). The two 4-input multiplexer circuits have individual active LOW Enables (\bar{E}_a, \bar{E}_b) which can be used to strobe the outputs independently. When the Enables (\bar{E}_a, \bar{E}_b) are HIGH, the corresponding outputs (\bar{Z}_a, \bar{Z}_b) are forced HIGH.

The 'F352 can be used to move data from a group of registers to a common output bus. The particular register from which the data came would be determined by the state of the Select inputs. A less obvious application is as a function generator. The 'F352 can generate two functions of three variables. This is useful for implementing highly irregular random logic.

The logic equations for the outputs are shown below:

$$\bar{Z}_a = \bar{E}_a \cdot (I_{0a} \cdot \bar{S}_1 \cdot \bar{S}_0 + I_{1a} \cdot \bar{S}_1 \cdot S_0 + I_{2a} \cdot S_1 \cdot \bar{S}_0 + I_{3a} \cdot S_1 \cdot S_0)$$

$$\bar{Z}_b = \bar{E}_b \cdot (I_{0b} \cdot \bar{S}_1 \cdot \bar{S}_0 + I_{1b} \cdot \bar{S}_1 \cdot S_0 + I_{2b} \cdot S_1 \cdot \bar{S}_0 + I_{3b} \cdot S_1 \cdot S_0)$$

Truth Table

Select Inputs		Inputs (a or b)					Output
S_0	S_1	\bar{E}	I_0	I_1	I_2	I_3	\bar{Z}
X	X	H	X	X	X	X	H
L	L	L	L	X	X	X	H
L	L	L	H	X	X	X	L
H	L	L	X	L	X	X	H
H	L	L	X	H	X	X	L
L	H	L	X	X	L	X	H
L	H	L	X	X	H	X	L
H	H	L	X	X	X	L	H
H	H	L	X	X	X	H	L

H = HIGH Voltage Level
 L = LOW Voltage Level
 X = Immaterial

Logic Diagram

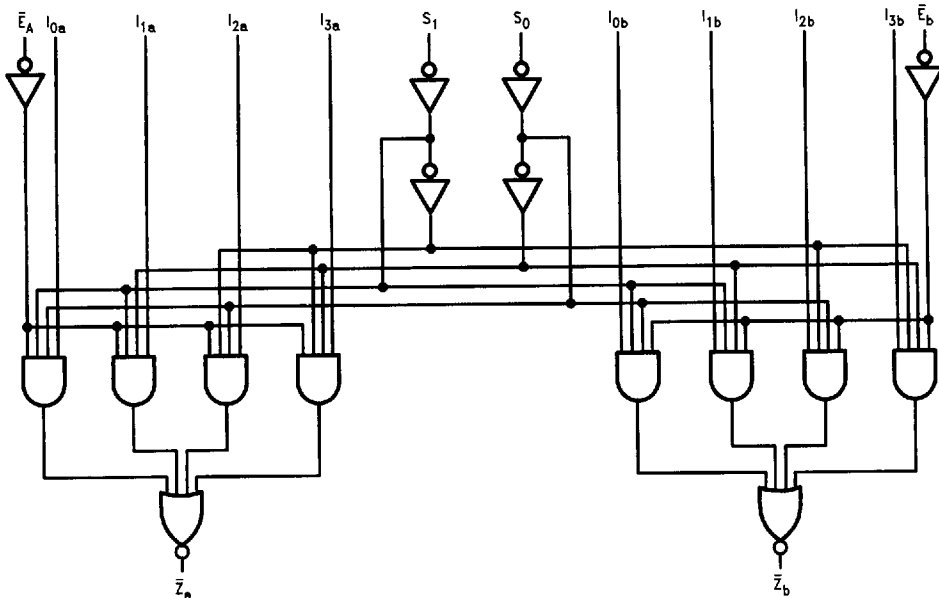

TL/F/9519-4

Please note that this diagram is provided only for the understanding of logic operations and should not be used to estimate propagation delays.

Absolute Maximum Ratings (Note 1)

Storage Temperature	-65°C to +150°C
Ambient Temperature under Bias	-55°C to +125°C
Junction Temperature under Bias	-55°C to +175°C
Plastic	-55°C to +150°C
V _{CC} Pin Potential to Ground Pin	-0.5V to +7.0V
Input Voltage (Note 2)	-0.5V to +7.0V
Input Current (Note 2)	-30 mA to +5.0 mA
Voltage Applied to Output in HIGH State (with V _{CC} = 0V)	
Standard Output	-0.5V to V _{CC}
TRI-STATE® Output	-0.5V to +5.5V
Current Applied to Output in LOW State (Max)	twice the rated I _{OL} (mA)

Note 1: Absolute maximum ratings are values beyond which the device may be damaged or have its useful life impaired. Functional operation under these conditions is not implied.

Note 2: Either voltage limit or current limit is sufficient to protect inputs.

Recommended Operating Conditions

Free Air Ambient Temperature	0°C to +70°C
Commercial	
Supply Voltage	
Commercial	+4.5V to +5.5V

DC Electrical Characteristics

Symbol	Parameter	74F			Units	V _{CC}	Conditions
		Min	Typ	Max			
V _{IH}	Input HIGH Voltage	2.0			V		Recognized as a HIGH Signal
V _{IL}	Input LOW Voltage			0.8	V		Recognized as a LOW Signal
V _{CD}	Input Clamp Diode Voltage			-1.2	V	Min	I _{IN} = -18 mA
V _{OH}	Output HIGH Voltage	74F 10% V _{CC} 74F 5% V _{CC}	2.5 2.7		V	Min	I _{OH} = -1 mA I _{OH} = -1 mA
V _{OL}	Output LOW Voltage	74F 10% V _{CC}		0.5	V	Min	I _{OL} = 20 mA
I _{IH}	Input HIGH Current	74F		5.0	μA	Max	V _{IN} = 2.7V
I _{BVI}	Input HIGH Current Breakdown Test	74F		7.0	μA	Max	V _{IN} = 7.0V
I _{CEX}	Output HIGH Leakage Current	74F		50	μA	Max	V _{OUT} = V _{CC}
V _{ID}	Input Leakage Test	74F	4.75		V	0.0	I _{ID} = 1.9 μA All Other Pins Grounded
I _{OD}	Output Leakage Circuit Current	74F		3.75	μA	0.0	V _{IOD} = 150 mV All Other Pins Grounded
I _{IL}	Input LOW Current			-0.6	mA	Max	V _{IN} = 0.5V
I _{OS}	Output Short-Circuit Current		-60	-150	mA	Max	V _{OUT} = 0V
I _{CCH}	Power Supply Current			9.3	mA	Max	V _O = HIGH
I _{CCL}	Power Supply Current			13.3	mA	Max	V _O = LOW

AC Electrical Characteristics: See Section 2 for Waveforms and Load Configurations

Symbol	Parameter	74F			74F		Units	Fig. No.
		T _A = +25°C V _{CC} = +5.0V C _L = 50 pF			T _A , V _{CC} = Com C _L = 50 pF			
		Min	Typ	Max	Min	Max		
t _{PLH} t _{PHL}	Propagation Delay S _n to \bar{Z}_n	4.0 3.5	8.0 6.5	11.0 8.5	3.5 3.0	12.5 9.5	ns	2-3
t _{PLH} t _{PHL}	Propagation Delay \bar{E}_n to \bar{Z}_n	3.0 3.0	4.5 5.0	6.0 7.0	2.5 2.5	7.0 8.0	ns	2-3
t _{PLH} t _{PHL}	Propagation Delay I _n to \bar{Z}_n	2.0 1.3	5.2 2.5	7.0 4.0	2.0 1.0	8.0 4.5	ns	2-3