

PART NUMBER CODING
SWT201-UP_N-S01-UU-UU

REVISIONS				
REV.	ECO. NO	DESCRIPTION	DATE	BY
A	2235	INITIAL RELEASE	05/25/2011	LH

PLATING

T = .000015" MIN NICKEL UNDERPLATE, .000040" MIN PURE TIN, BRIGHT OVERALL (NOTE 7).

P = .000040" MIN. NICKEL UNDERPLATE, GOLD FLASH OVERALL.

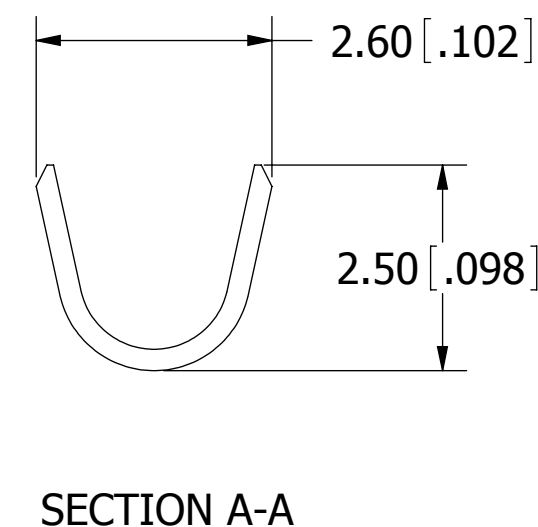
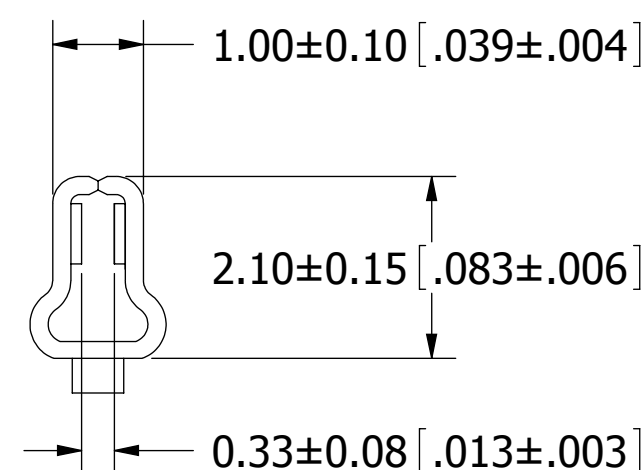
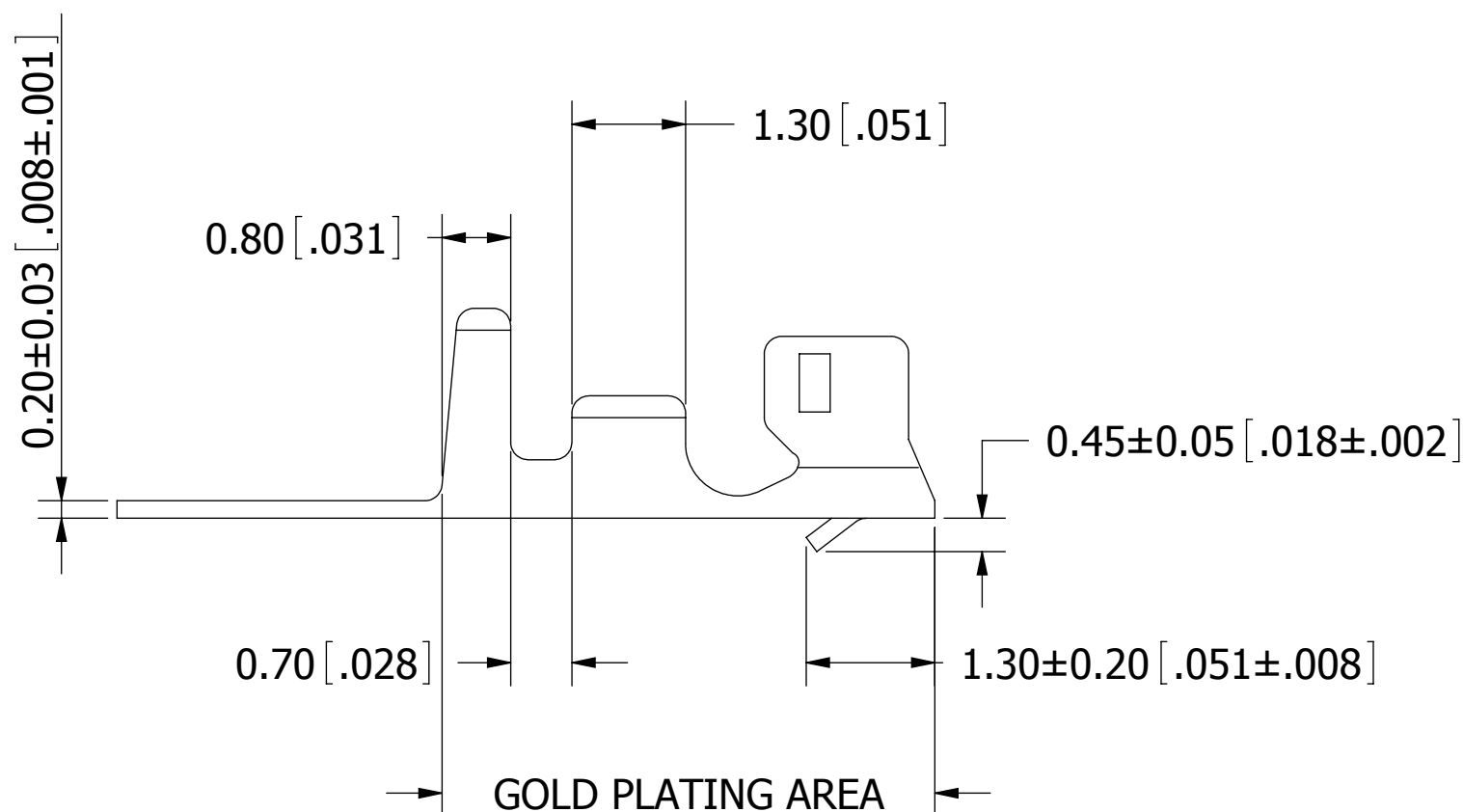
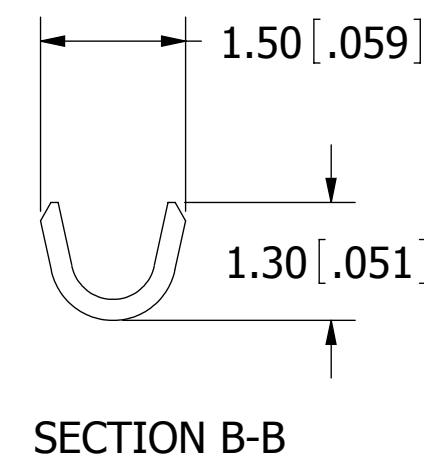
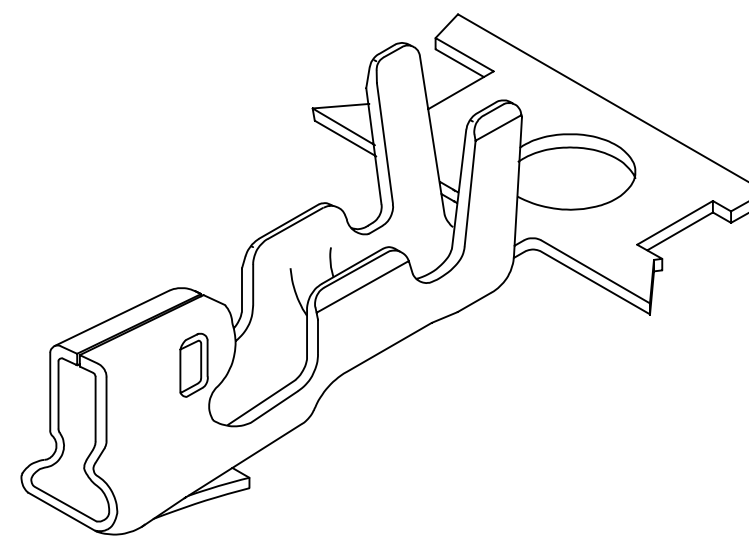
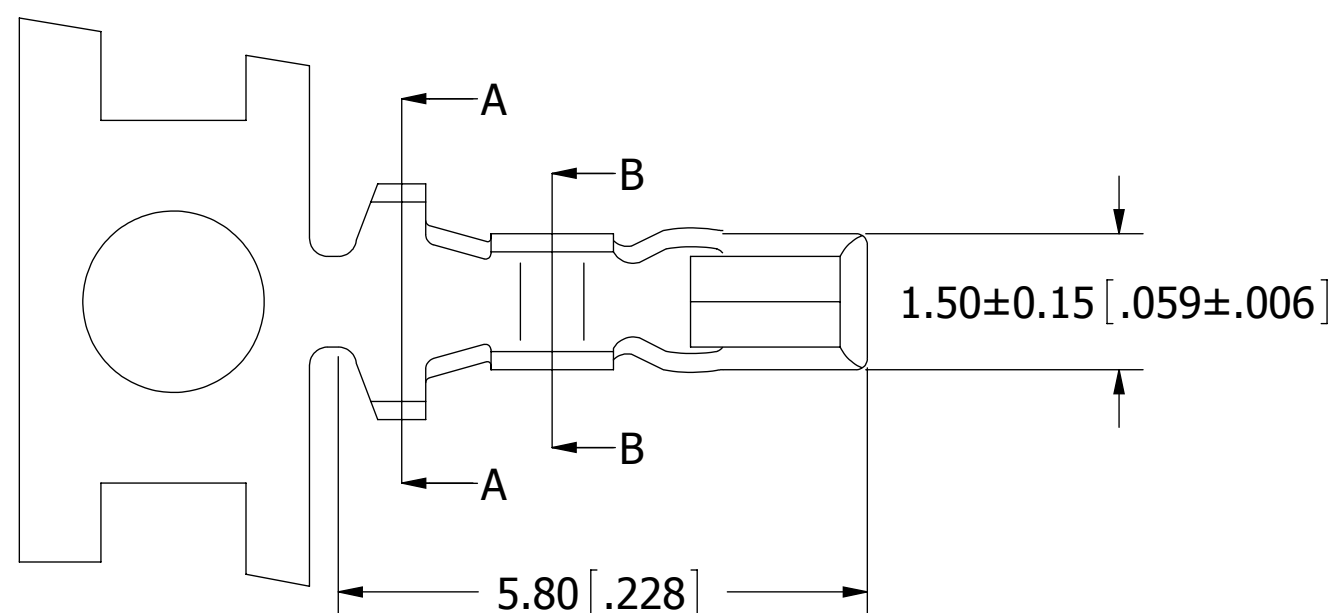

NOTES:

1. MATERIAL: PHOSPHOR BRONZE.
2. PLATING: SEE PART NUMBER CODING.
3. WIRE RANGE: AWG #24 - #28.
4. INSULATION O.D.: ϕ 1.20mm ~ ϕ 1.50mm.
5. QUANTITY PER REEL = 10,000 PIECES.
6. USED IN SWH201 SERIES HOUSING.
7. PLATING BEFORE STAMPING/FORMING.

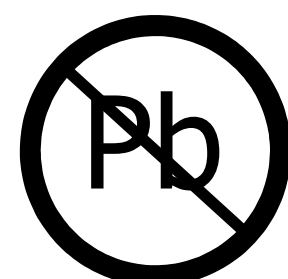

RoHS COMPLIANT

UNLESS OTHERWISE SPECIFIED: DIMENSIONS ARE IN MM[INCHES]	DRAWN	DATE	NAME	
		05/25/2011	LH	
TOLERANCES: ANGULAR: .X= ± 0.3 [.01] .XX= ± 0.30 [.012]	THE INFORMATION HEREIN CONTAINS PROPRIETARY INFORMATION OF SULLINS ELECTRONICS AND IS NOT TO BE REPRODUCED, USED OR DISCLOSED TO OTHERS FOR ANY PURPOSE EXCEPT AS SPECIFICALLY AUTHORIZED IN WRITING BY AN OFFICER OF SULLINS ELECTRONICS.			
	INTERPRET DIMENSIONS AND TOLERANCING PER: ASME Y14.5M-2009			
TITLE		CRIMP TERMINAL - SWH201		
PART NUMBER		SWT201-UP_N-S01-UU-UU		
SIZE	CAGE CODE	DWG. NO.	REV	
C	54453	11621	A	
SCALE: 12:1		SHEET 1 OF 1		