

THIS DRAWING IS UNPUBLISHED. RELEASED FOR PUBLICATION
 © COPYRIGHT - By - ALL RIGHTS RESERVED.

LOC		DIST		REVISIONS			
P	LTR	DESCRIPTION		DATE	DWN	APVD	
	H	REVISED PER ECO-15-004048		17MAR2015	NK	RH	

CONVERSION CHART		CONVERSION CHART	
INCH	MM	INCH	MM
.002	0,05	.374	9,49
.005	0,12	.396	10,06
.008	0,20	.400	10,16
.010	0,25	.524	13,31
.014	0,36		
.018	0,44		
.020	0,52		
.028	0,71		
.030	0,76		
.035	0,89		
.040	1,02		
.043	1,09		
.045	1,14		
.060	1,52		
.065	1,65		
.076	1,94		
.082	2,08		
.090	2,29		
.094	2,39		
.100	2,54		
.110	2,80		
.120	3,05		
.125	3,18		
.126	3,19		
.130	3,30		
.155	3,94		
.156	3,96		
.160	4,06		
.162	4,11		
.170	4,32		
.180	4,57		
.189	4,80		
.195	4,95		
.200	5,08		
.230	5,84		
.240	6,10		
.300	7,62		
.320	8,13		
.360	9,14		
.362	9,19		
.370	9,40		

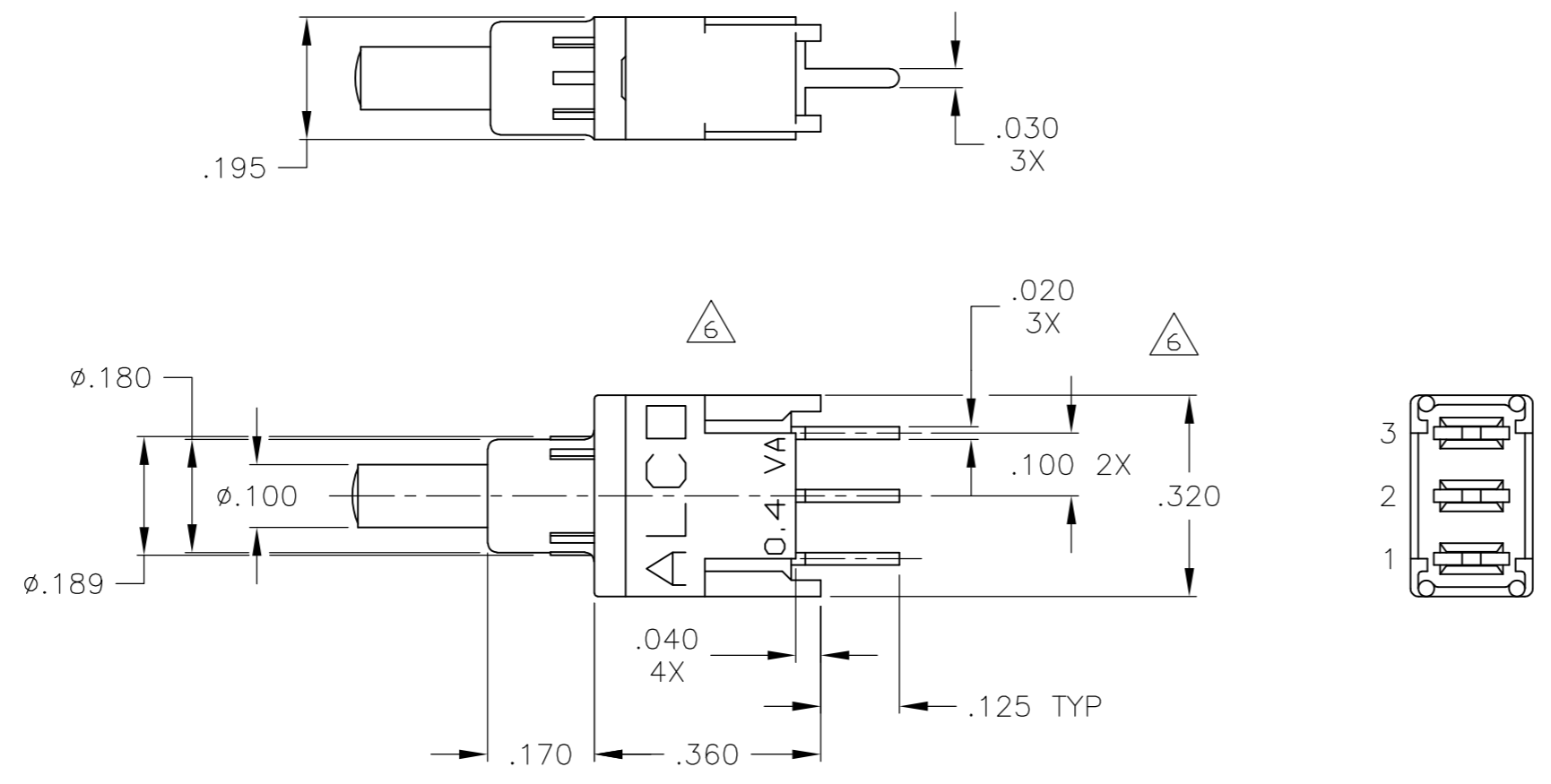

PC MOUNT

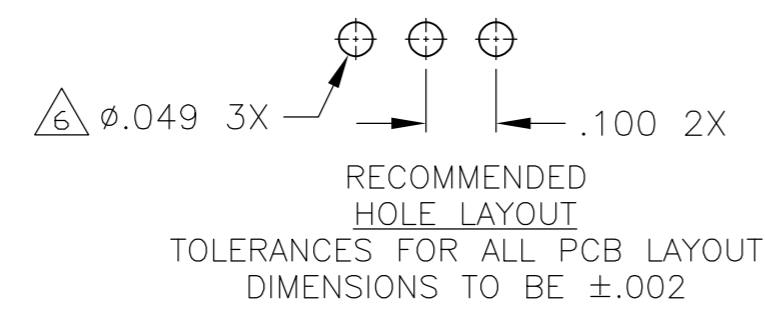

SPECIFICATIONS:

MATERIALS:

CASE: HIGH TEMPERATURE POLYESTER.
 ACTUATOR: POLYAMIDE.
 MOVING CONTACT: COPPER ALLOY, GOLD PLATE OVER NICKEL.
 FIXED CONTACT: COPPER ALLOY, GOLD PLATE OVER NICKEL.
 TERMINALS: COPPER ALLOY, TIN-LEAD PLATE.

ELECTRICAL:

CONTACT RATING: 0.4VA @ 20 VAC/DC
 INITIAL CONTACT RESISTANCE: 20 MILLIOHMS MAX.
 INSULATION RESISTANCE: 1000 MEGOHMS @ 500V DC MIN.
 DIELECTRIC STRENGTH: C 1000 VOLTS RMS AT SEA LEVEL.
 F 500 VOLTS RMS AT SEA LEVEL.
 LIFE EXPECTANCY: C 80,000 CYCLES
 F 60,000 CYCLES.

MECHANICAL:

ACTUATION TRAVEL: .035.

ENVIRONMENTAL:

OPERATING TEMPERATURE: -22°F TO +185°F
 (-30°C TO +85°C).
 STORAGE TEMPERATURE: -67°F TO +185°F
 (-55°C TO +85°C)

NOTES:

1. INTERPRET DRAWING PER ASME Y14.5M-1994.

PART NUMBERING SEQUENCE

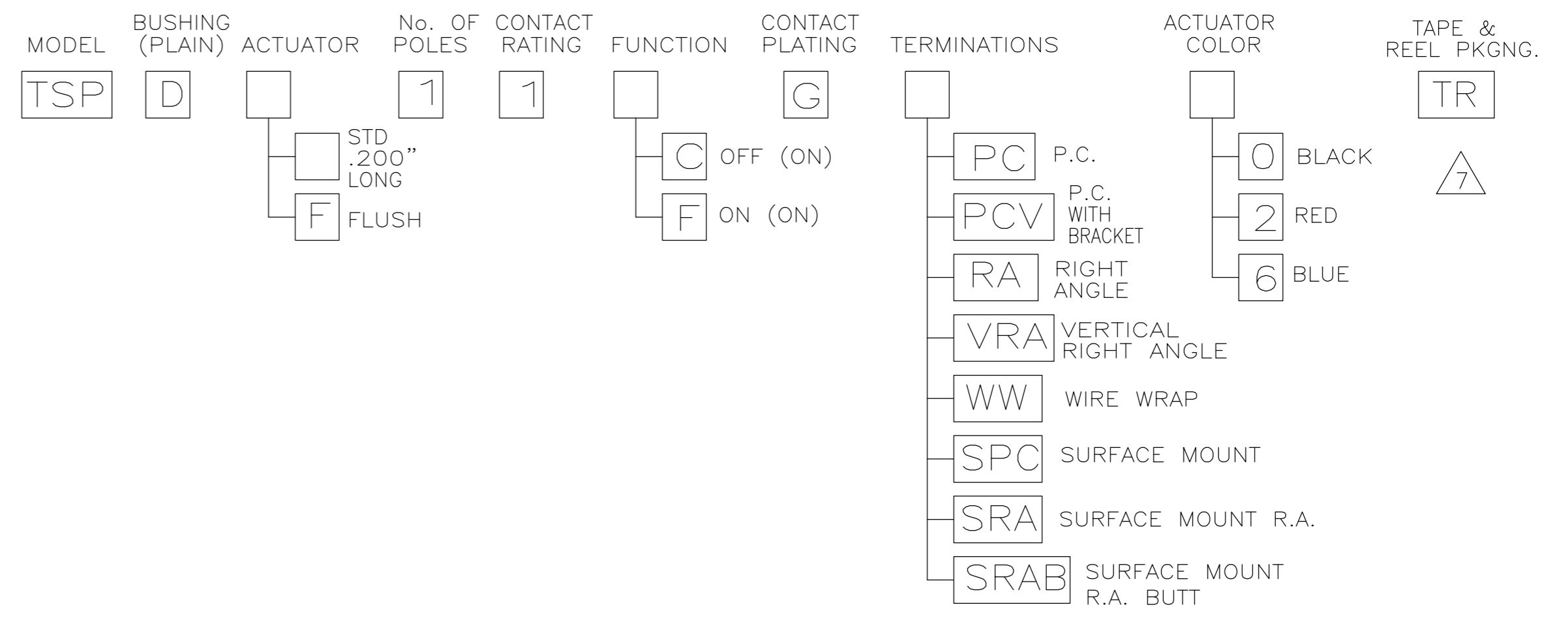

FIGURE 1

FUNCTION CHART	
THE FOLLOWING FUNCTIONS AVAILABLE IN SINGLE POLE.	
[C] 2 POSITIONS OFF (ON) TERMINALS CONNECTED: [1-3] OMIT CENTER TERMINAL FOR FUNCTION [C]	
[F] 2 POSITIONS ON (ON) TERMINALS CONNECTED: [1-2] [2-3]	
OFF INDICATES A MECHANICAL POSITION WITH NO ELECTRICAL CONNECTION. (ON) INDICATES MOMENTARY ACTION	

FILE NAME: 40287S1L	DIRECTORY: PSHSWTCH	CODE IDENT. NO. 91506	PRODUCT CODE: B53	THIS DRAWING IS A CONTROLLED DOCUMENT.		DWN C.M.M. 9-19-90 CHK B.J.A. 12-20-90 APVD B.J.A. 12-20-90 PRODUCT SPEC APPLICATION SPEC	TE Connectivity NAME: OUTLINE DRAWING SEALED PUSHBUTTON SWITCH SINGLE POLE TSP SERIES		
				DIMENSIONS: INCHES	TOLERANCES UNLESS OTHERWISE SPECIFIED:	SIZE A2	CAGE CODE 00779	DRAWING NO. C=1-1437573-1	RESTRICTED TO
					0 PLC ± - 1 PLC ± - 2 PLC ± - 3 PLC ± .010 4 PLC ± - ANGLES ± 1°	WEIGHT -	SCALE 4:1	SHEET 1 of 4	REV H
				MATERIAL SEE SPECIFICATIONS	FINISH SEE NOTES	CUSTOMER DRAWING			

1-1437573-1

A

THIS DRAWING IS UNPUBLISHED. RELEASED FOR PUBLICATION
 © COPYRIGHT - By - ALL RIGHTS RESERVED.

LOC		DIST		REVISIONS			
P	LTR	DESCRIPTION	DATE	DWN	APVD		
-	-	SEE SHEET 1	-	-	-		

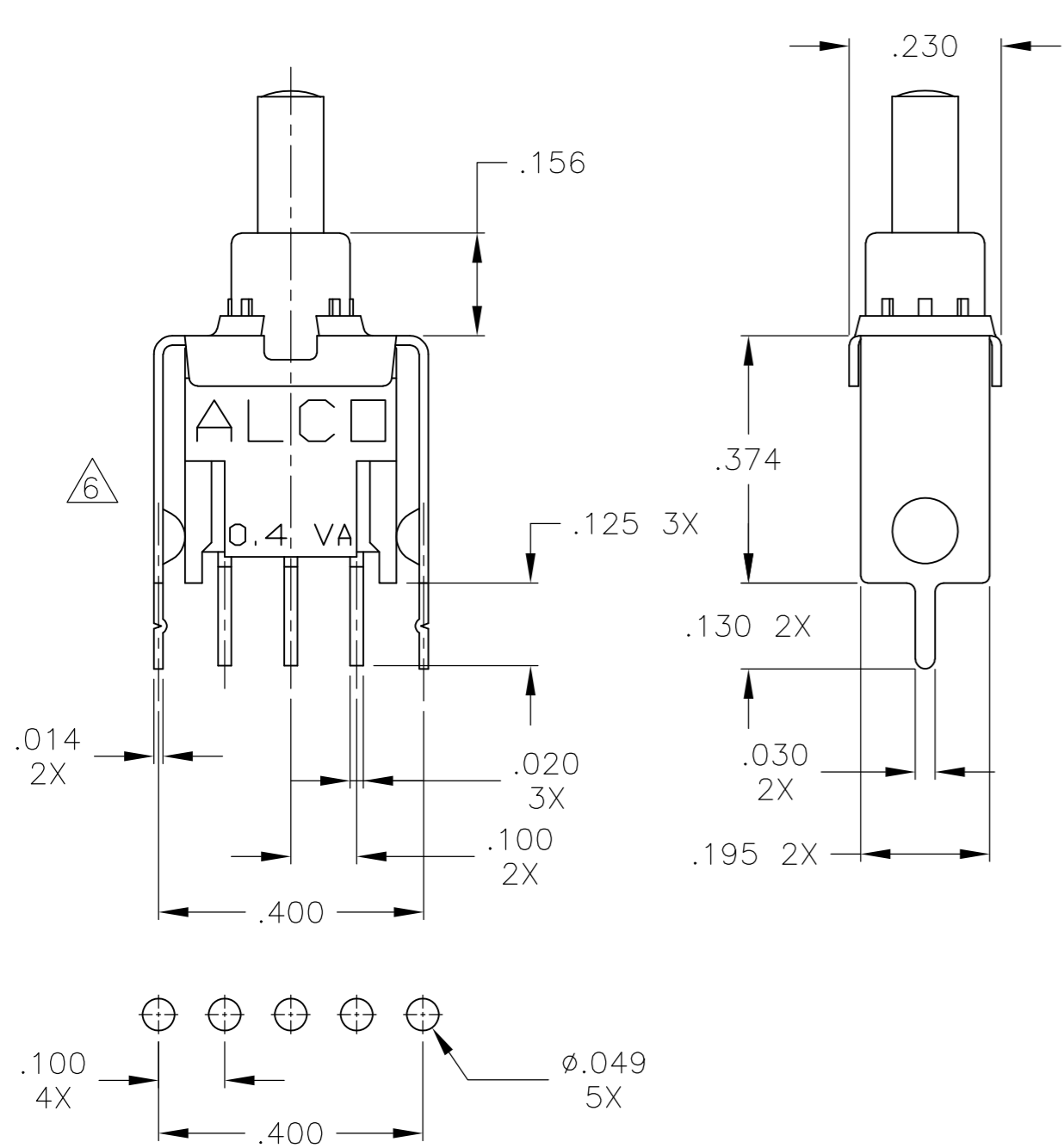

RECOMMENDED HOLE LAYOUT
 TOLERANCES $\pm.002$ UNLESS
 OTHERWISE NOTED.

PCV PC WITH VERTICAL
 SUPPORT BRACKET

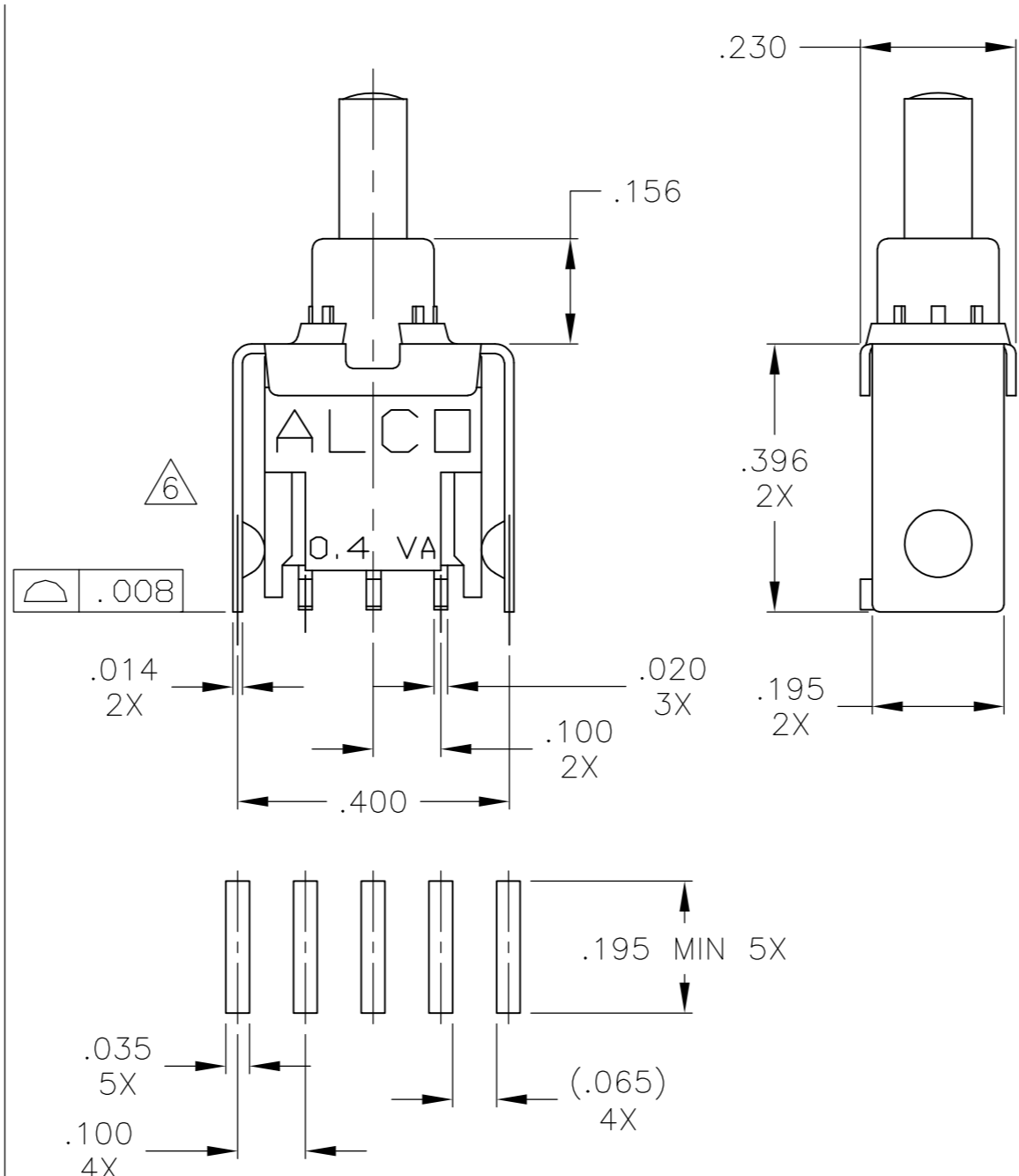

RECOMMENDED HOLE LAYOUT
 TOLERANCES $\pm.002$ UNLESS
 OTHERWISE NOTED.

SPC SURFACE MOUNT

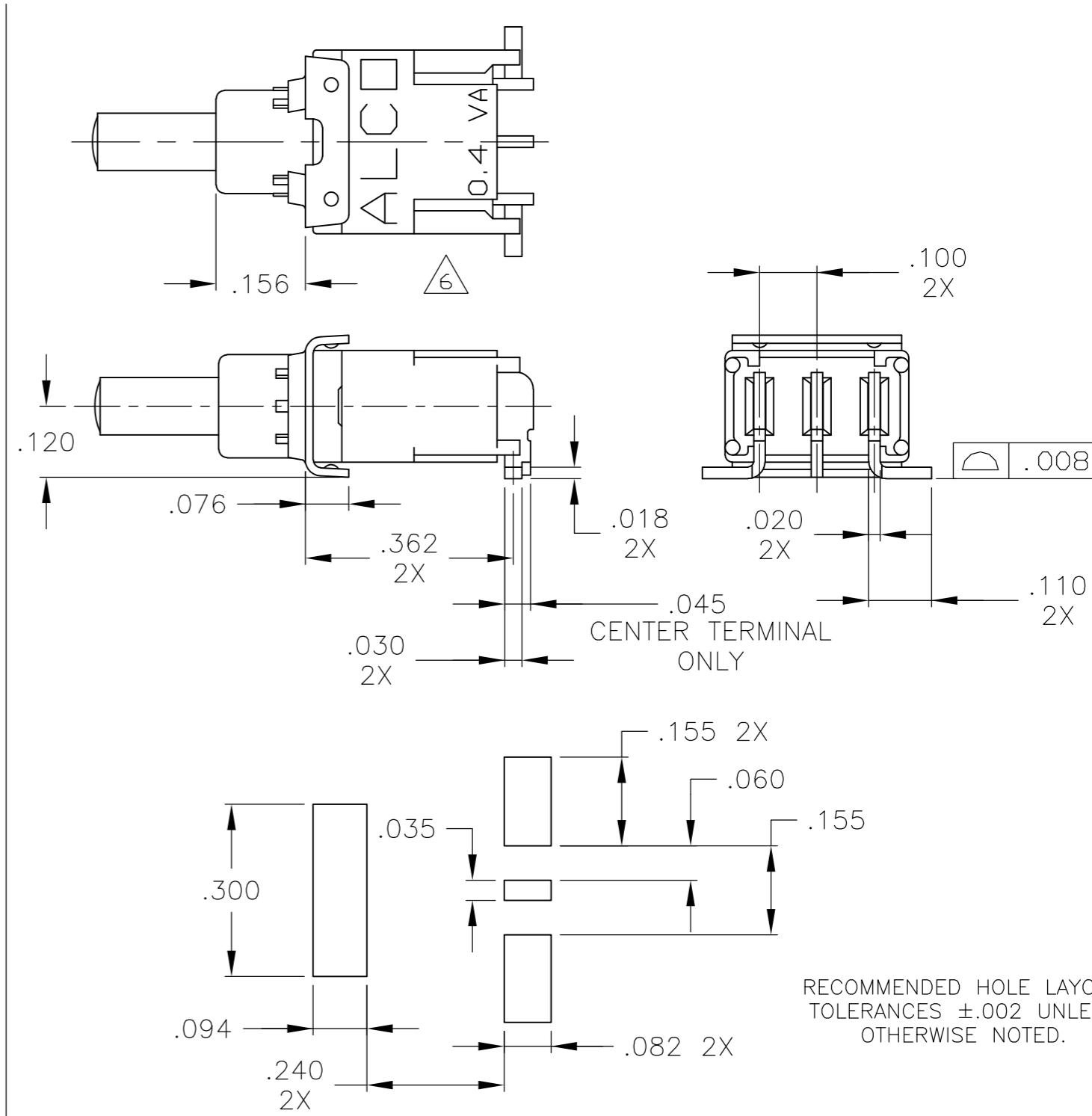

RECOMMENDED HOLE LAYOUT
 TOLERANCES $\pm.002$ UNLESS
 OTHERWISE NOTED.

SRA SURFACE MOUNT RIGHT ANGLE,
 "L" BENDA

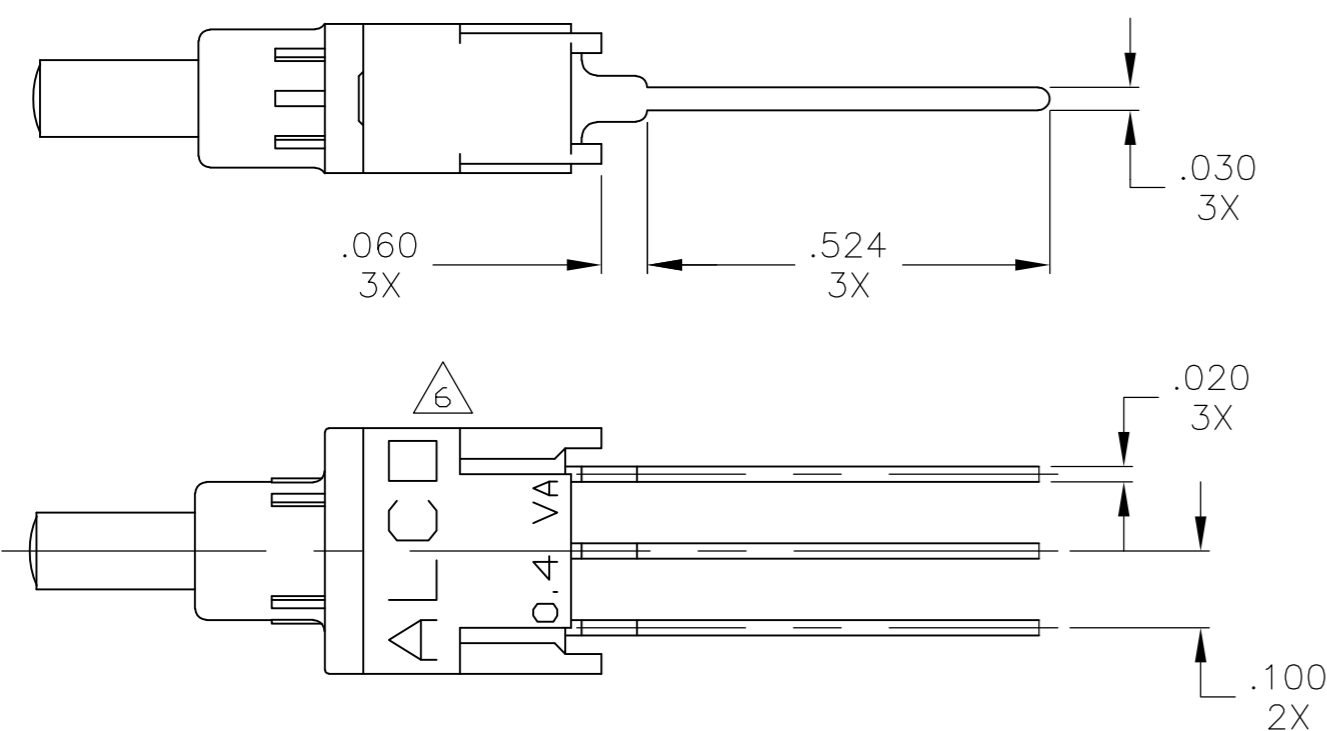

WW WIRE WRAP

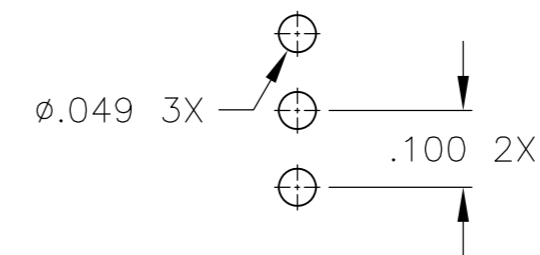

RECOMMENDED HOLE LAYOUT
 TOLERANCES $\pm.002$ UNLESS
 OTHERWISE NOTED.

FILE NAME: 40287S1L		DIRECTIONS: INCHES		TOLERANCES UNLESS OTHERWISE SPECIFIED:		DWN: C.M.M. 9-19-90				
DIRECTOR: PSHSWTCH				0 PLC $\pm -$ 1 PLC $\pm -$ 2 PLC $\pm -$ 3 PLC $\pm .010$ 4 PLC $\pm -$ ANGLES $\pm 1^\circ$		CHK: B.J.A. 12-20-90				NAME: OUTLINE DRAWING SEALED PUSHBUTTON SWITCH SINGLE POLE TSP SERIES
CODE IDENT. NO. 91506		MATERIAL: SEE SPECIFICATIONS		FINISH: SEE NOTES		APVD: B.J.A. 12-20-90		DRAWING NO. A2 00779		RESTRICTED TO
PRODUCT CODE: B53						APPLICATION SPEC: -		SCALE: 4:1		REV: H
						WEIGHT: -		CAGE CODE: 00779		SHEET: 2 of 4
						CUSTOMER DRAWING		DRAWING NO. 1-1437573-1		

THIS DRAWING IS UNPUBLISHED. RELEASED FOR PUBLICATION
 © COPYRIGHT - By - ALL RIGHTS RESERVED.

LOC		DIST		REVISIONS			
P	LTR	DATE	DWN	APVD	DESCRIPTION		
-	-	-	-	-	SEE SHEET 1		

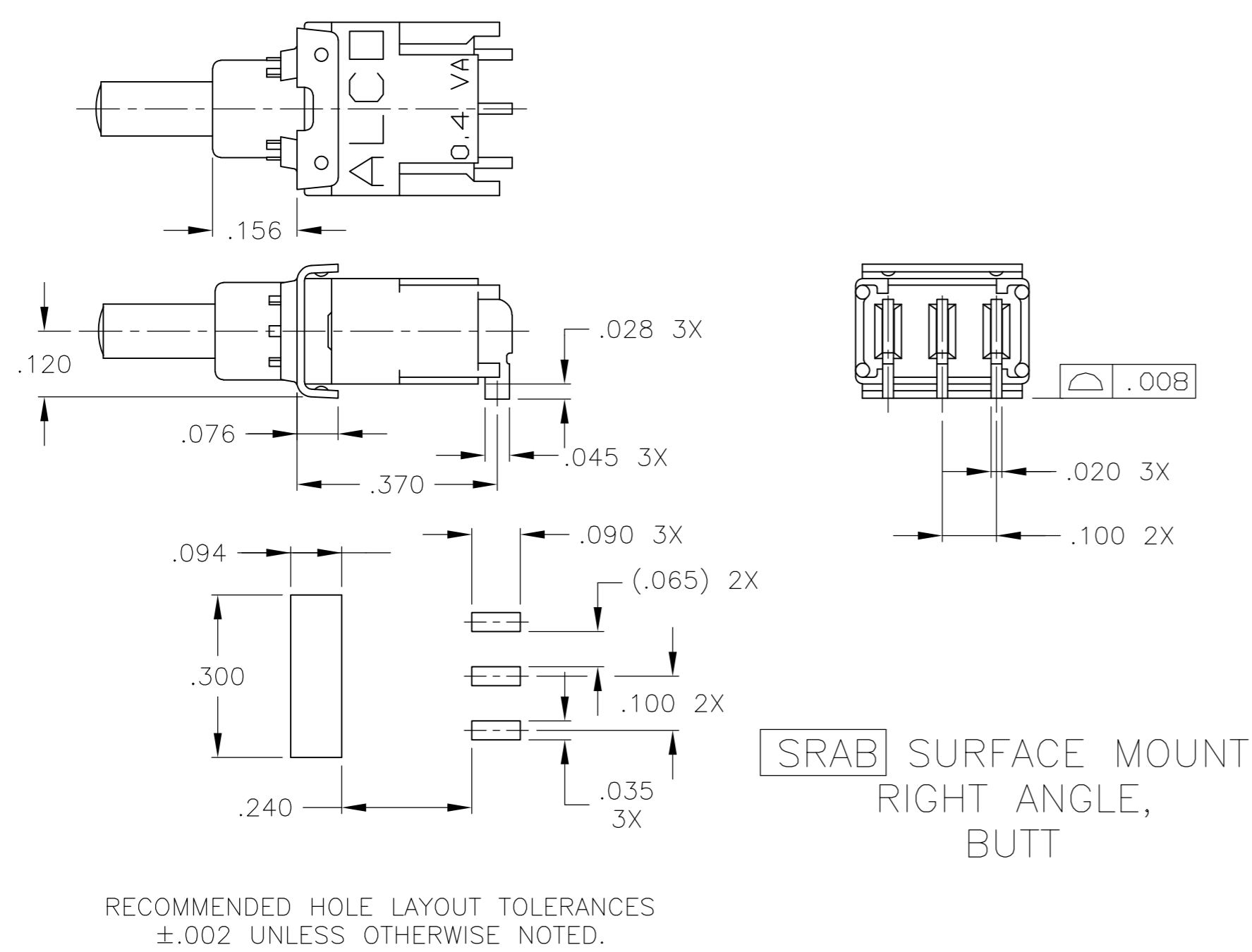
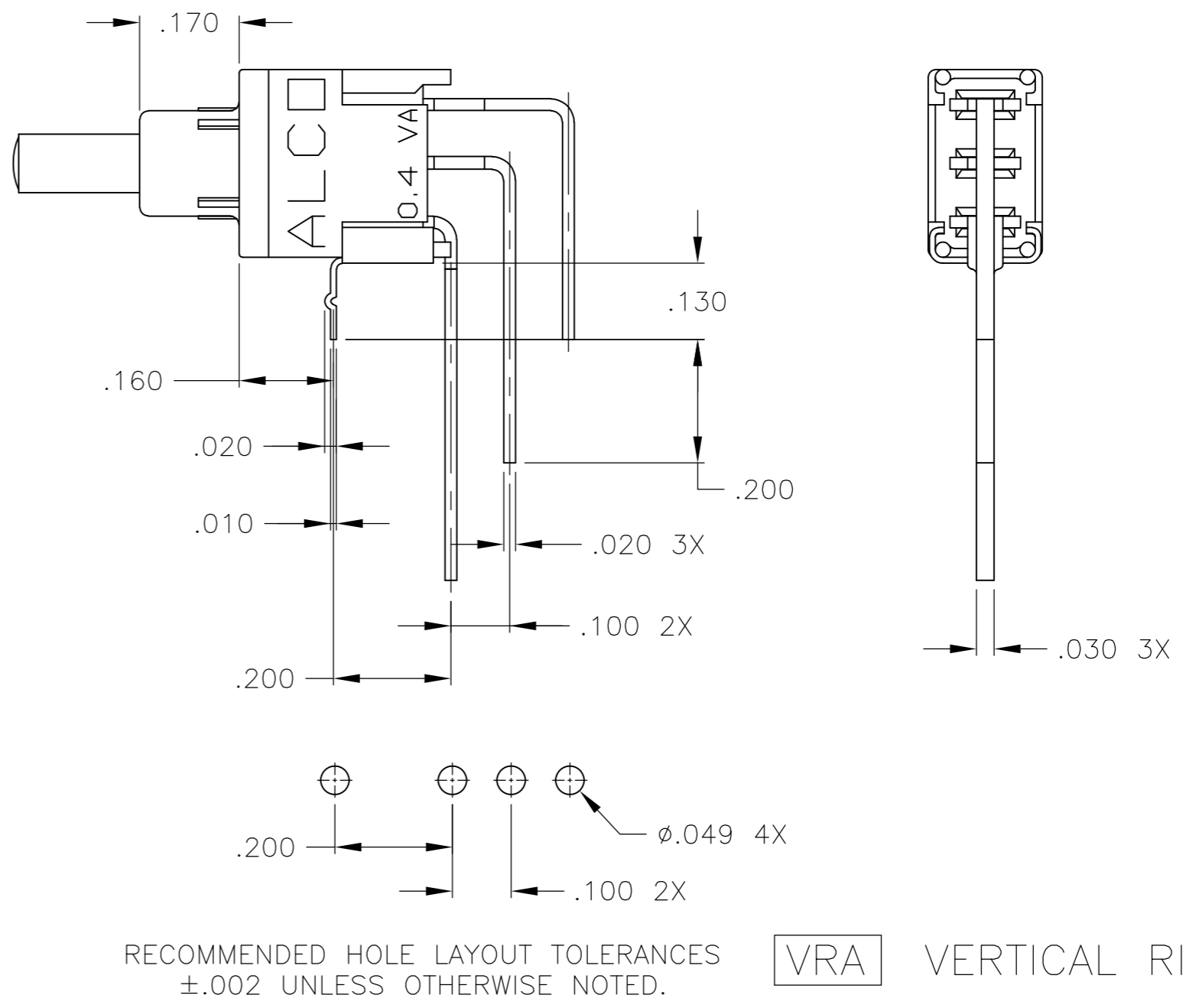
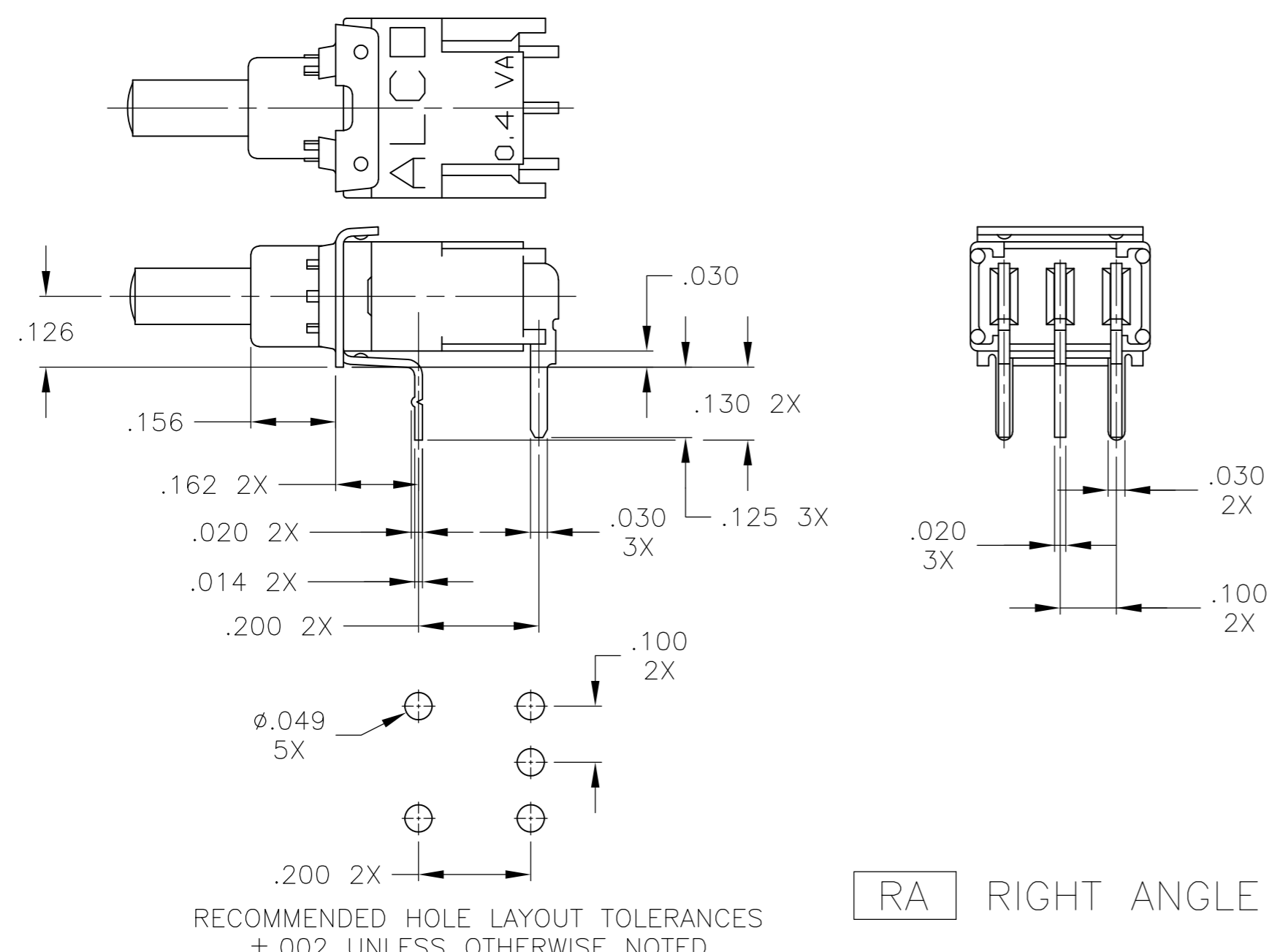

ACTUATORS

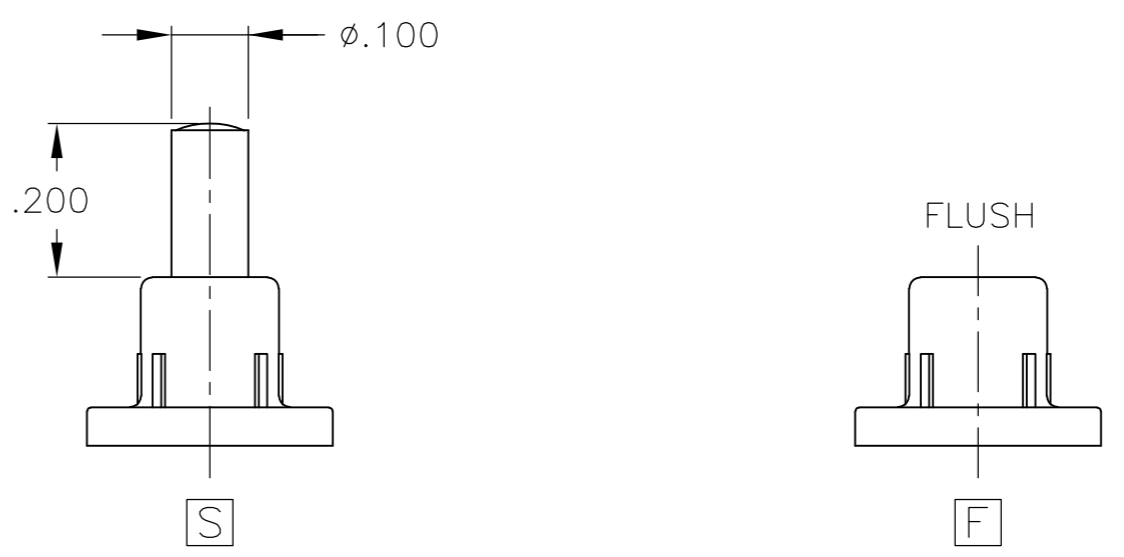

FILE NAME: 40287S1L	DIMENSIONS: INCHES	TOLERANCES UNLESS OTHERWISE SPECIFIED:	DWN C.M.M. 9-19-90		RESTRICTED TO	
DIRECTORY: PSHSWCH		0 PLC ± -	CHK B.J.A. 12-20-90		NAME OUTLINE DRAWING SEALED PUSHBUTTON SWITCH SINGLE POLE TSP SERIES	RESTRICTED TO
CODE IDENT. NO. 91506		1 PLC ± -	APVD B.J.A. 12-20-90	SIZE A2	CAGE CODE 00779	DRAWING NO. 1-1437573-1
PRODUCT CODE: B53	MATERIAL SEE SPECIFICATIONS	2 PLC ± -	PRODUCT SPEC	SCALE 4:1	SHEET 3 of 4	REV H
		3 PLC ± .010	APPLICATION SPEC			
		4 PLC ± -	WEIGHT -			
		ANGLES ± 1°	CUSTOMER DRAWING			
		FINISH				
		SEE NOTES				

THIS DRAWING IS UNPUBLISHED. RELEASED FOR PUBLICATION
 © COPYRIGHT - By - ALL RIGHTS RESERVED.

LOC	DIST	REVISIONS					
		P	LTR	DESCRIPTION	DATE	DWN	APVD
-	-	-	-	SEE SHEET 1	-	-	-

	TSPD11CGPC0	1-1437573-1
	TSPD11CGPC2	1-1437573-3
	TSPD11CGPCV0	1-1437573-4
	TSPD11CGRA0	1-1437573-5
	TSPD11CGRA2	1-1437573-7
OBSOLETE	TSPD11CGRA6	4-1437573-2
	TSPD11CGSPC0	1-1437573-8
	TSPD11CGSPC2	4571210-1
	TSPD11CGSRA0TR	1571733-1
	TSPD11CGSRA0	1-1437573-9
	TSPD11CGSRA2	2-1437573-0
OBSOLETE	TSPD11CGSRAB0	2-1437573-1
	TSPD11CGVRA0	2-1437573-2
	TSPD11CGWW0	2-1437573-3
	TSPD11FGPC0	2-1437573-4
	TSPD11FGPCV0	2-1437573-5
	TSPD11FGRA0	2-1437573-6
OBSOLETE	TSPD11FGSPC0	2-1437573-7
	TSPD11FGSRA0	2-1437573-8
	TSPD11FGSRAB0	2-1437573-9
	TSPD11FGVRA0	3-1437573-0
	TSPDF11CGPC0	3-1437573-1
OBSOLETE	TSPDF11CGSRAB0TR	4571460-1
	TSPDF11CGSRA0TR	4571533-1
	TSPDF11CGRA0	3-1437573-2
	TSPDF11CGSRA0	3-1437573-3
	TSPDF11CGVRA0	3-1437573-4
	TSPDF11FGPC0	3-1437573-5
	TSPDF11FGRA0	3-1437573-6
OBSOLETE	TSPDF11FGSRA0	3-1437573-7
PRELIMINARY PART	TSPDF11FGVRA0	1571369-1
	MODEL NUMBER	PART NUMBER

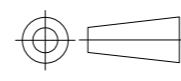
FILE NAME: 40287S1L	THIS DRAWING IS A CONTROLLED DOCUMENT.		DWN C.M.M. 9-19-90	 TE Connectivity	
DIRECTORY: PSHSWCH	DIMENSIONS: INCHES	TOLERANCES UNLESS OTHERWISE SPECIFIED:	CHK B.J.A. 12-20-90		
CODE IDENT. NO. 91506		0 PLC ± -	APVD B.J.A. 12-20-90	NAME OUTLINE DRAWING SEALED PUSHBUTTON SWITCH SINGLE POLE TSP SERIES	
PRODUCT CODE: B53		MATERIAL SEE SPECIFICATIONS	1 PLC ± - 2 PLC ± - 3 PLC ± .010 4 PLC ± - ANGLES ± 1°		
		FINISH SEE NOTES	WEIGHT -	SIZE A2	CAGE CODE 00779
			CUSTOMER DRAWING	DRAWING NO. 1-1437573-1	RESTRICTED TO -
				SCALE 4:1	SHEET 4 of 4
				REV H	