

LOW POWER AND LOW OFFSET VOLTAGE SUPER SMALL-SIZED SINGLE C-MOS COMPARATOR

■GENERAL DESCRIPTION

The NJU7108 is a super small-sized package single C-MOS comparator with push pull output.

The operating voltage is from 1V to 5.5V, and the interface can be connected with most of TTL and C-MOS type standard logic ICs.

Furthermore, The input offset voltage is lower than 4mV and Low operating current 10 μ A, therefore they can be suitable for battery use items and other portable items.

The NJU7108 is available in small package SC-88A.

■PACKAGE INFORMATION



**NJU7108F3
(SC- 88A)**

■FEATURES

- Single Low Power Supply $V_{DD}=1.0\sim 5.5V$
- Low Offset Voltage $V_{IO}=4mV$ max.
- Low Operating Current $I_{DD}=10\mu A$ typ.
- Push Pull Output
- Package Outline SC-88A
- C-MOS Technology

■PIN CONFIGURATION

**NJU7108F3
(Top View)**

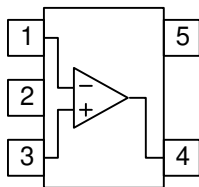

PIN CONFIGURATION

1. -INPUT
2. V_{SS}
3. +INPUT
4. OUTPUT
5. V_{DD}

■EQUIVALENT CIRCUIT

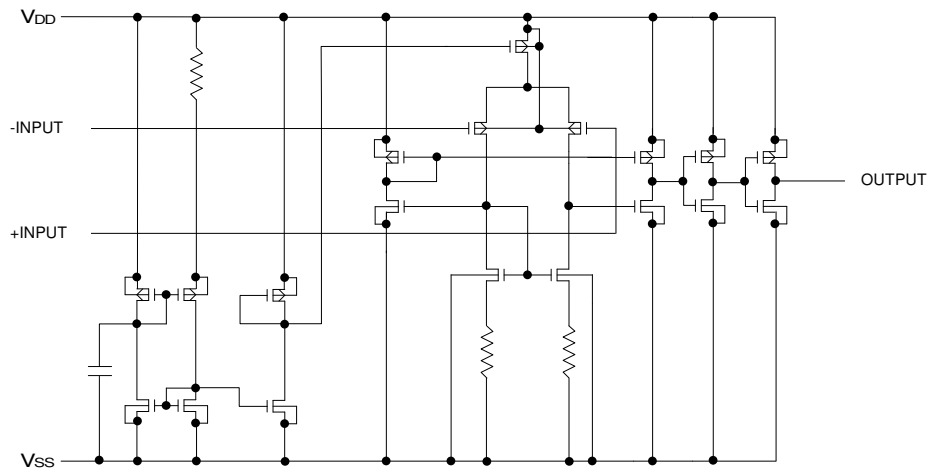

■ABSOLUTE MAXIMUM RATINGS

(Ta=25°C)

PARAMETER	SYMBOL	RATING	UNIT
Supply Voltage	V _{DD}	7.0	V
Differential Input Voltage	V _{ID}	±7.0 (Note1)	V
Common Mode Input Voltage	V _{IC}	-0.3~7.0 (Note1)	V
Power Dissipation	P _D	250 (Note2)	mW
Operating Temperature	Topr	-40~+85	°C
Storage Temperature	Tstg	-55~+125	°C

(Note1) For supply voltage less than +7.0V, the absolute maximum input voltage is equal to supply voltage.

(Note2) Mounted on a glass epoxy board (FR-4) in size of 50x50x1.6mm.

(Note3) Decoupling capacitor should be connected between V_{DD} and V_{SS} due to the stabilized operation for the circuit. □

■ELECTRICAL CHARACTERISTICS

(V_{DD}=3.0V, R_L=∞, Ta=25°C)

PARAMETER	SYMBOL	CONDITIONS	MIN	TYP	MAX	UNIT
Operating Voltage	V _{DD}		1.0	-	5.5	V
Input Offset Voltage	V _{IO}	V _{IN} =V _{DD} /2	-	-	4	mV
Input Offset Current	I _{IO}		-	1	-	pA
Input Bias Current	I _{IB}		-	1	-	pA
Input Common Mode Voltage Range	V _{ICM}		0~2.5	-	-	V
High Level Output Voltage	V _{OH}	I _{OH} =-5mA	2.7	-	-	V
Low Level Output Voltage	V _{OL}	I _{OL} =+5mA	-	-	0.3	V
Supply Current	I _{DD}		-	10	20	μA

(V_{DD}=3.0V, f=10kHz, C_L=15pF, Ta=25°C)

PARAMETER	SYMBOL	CONDITIONS	MIN	TYP	MAX	UNIT
Propagation Delay Low to High	t _{PLH}	Over Drive=100mV	-	500	-	ns
Propagation Delay High to Low	t _{PHL}	Over Drive=100mV	-	190	-	ns
Output Signal Rising Time	t _{TLH}	Over Drive=100mV	-	10	-	ns
Output Signal Falling Time	t _{THL}	Over Drive=100mV	-	5	-	ns

■TIMING WAVEFORM

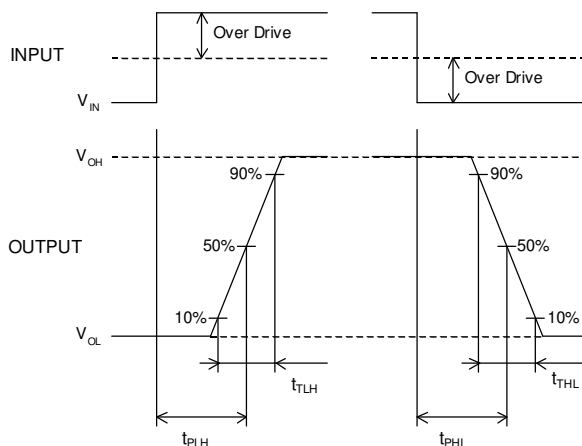

■ TYPICAL CHARACTERISTICS

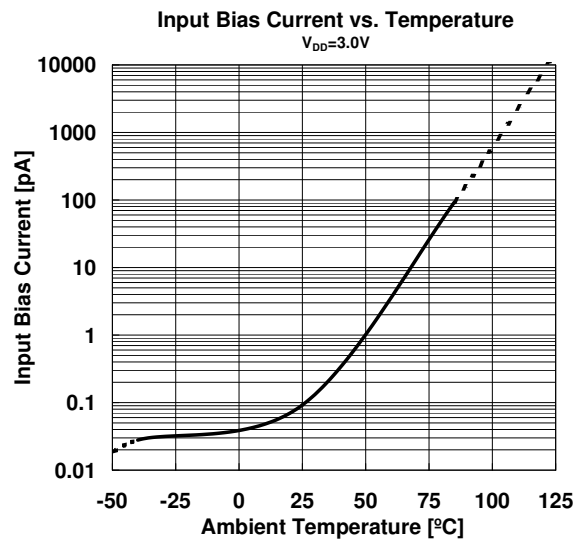
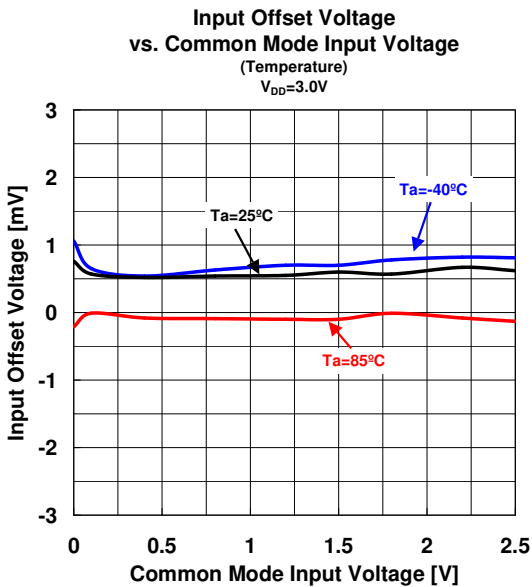
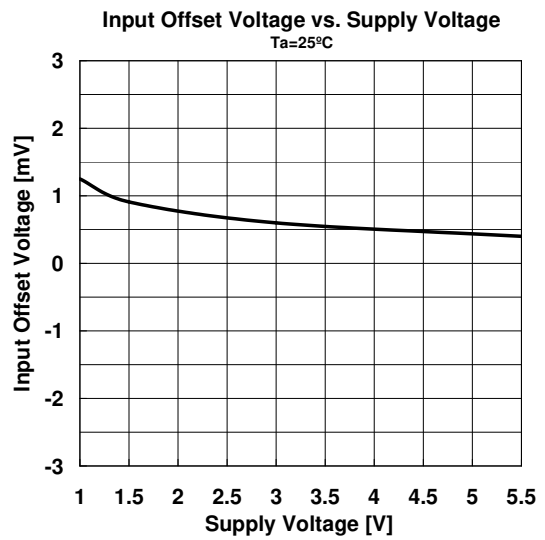
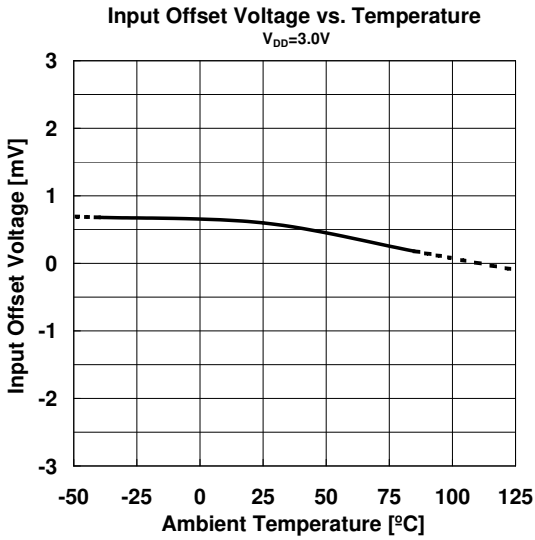
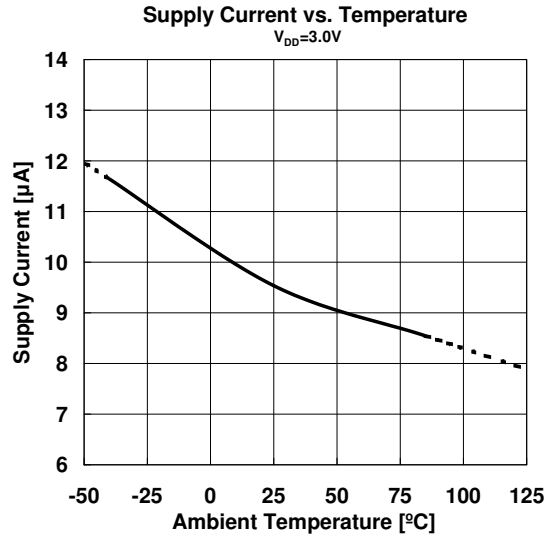
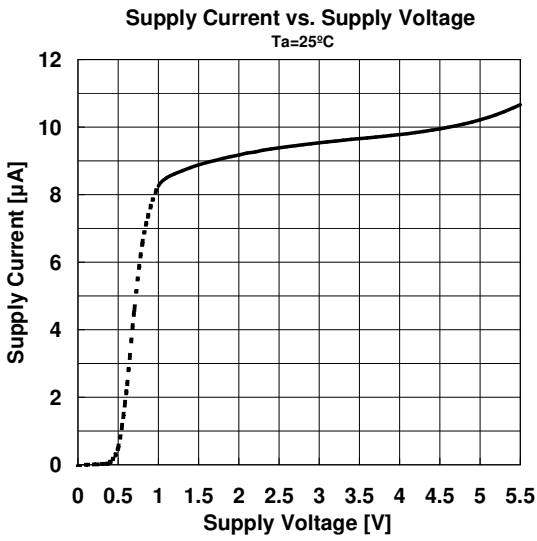

TYPICAL CHARACTERISTICS

High Level Output Voltage vs. Output Current
(Temperature)
 $V_{DD}=1.0V$

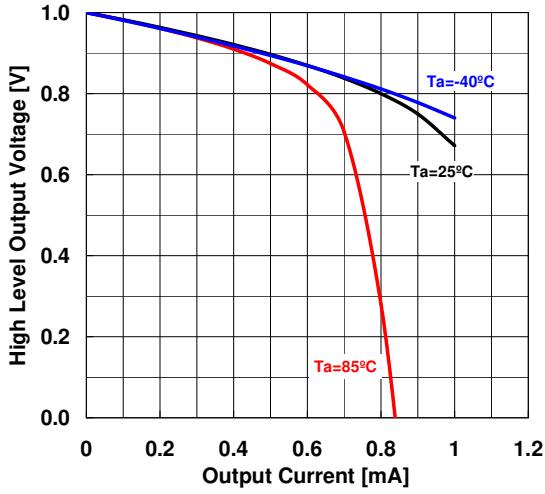

Low Level Output Voltage vs. Output Current
(Temperature)
 $V_{DD}=1.0V$

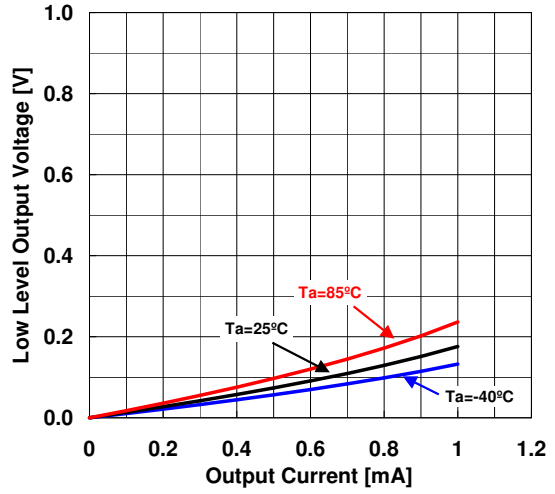

High Level Output Voltage vs. Output Current
(Temperature)
 $V_{DD}=3.0V$

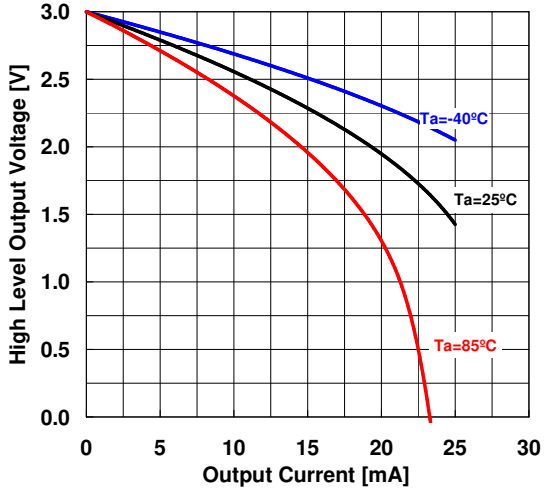

Low Level Output Voltage vs. Output Current
(Temperature)
 $V_{DD}=3.0V$

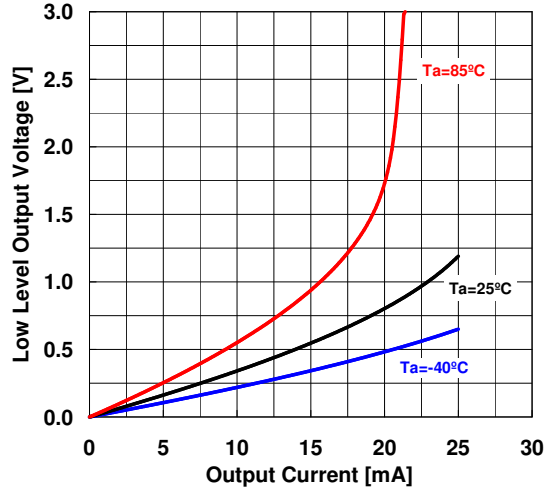

High Level Output Voltage vs. Output Current
(Temperature)
 $V_{DD}=5.5V$

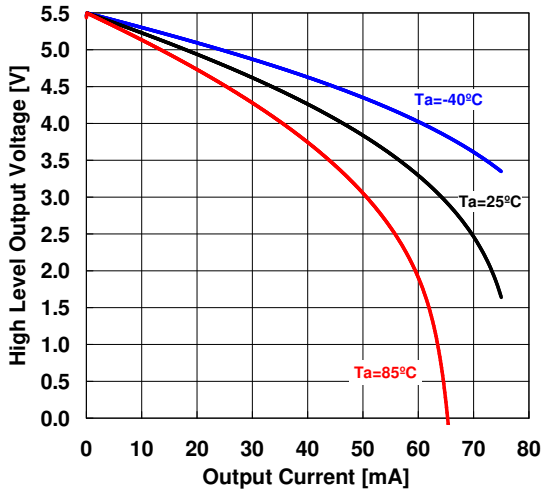

Low Level Output Voltage vs. Output Current
(Temperature)
 $V_{DD}=5.5V$

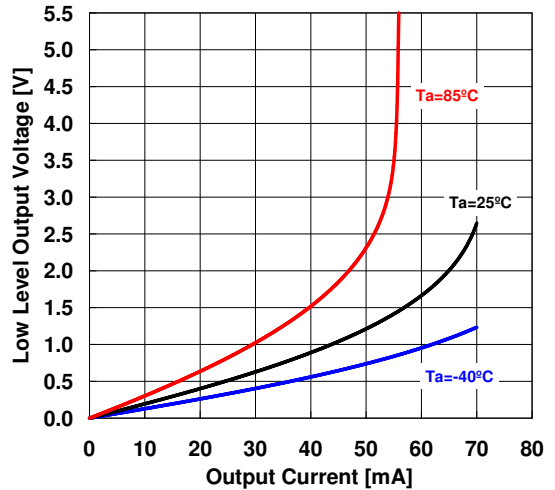

■ TYPICAL CHARACTERISTICS

Propagation Delay t_{PLH}

$V_{DD}/V_{SS}=\pm 1.5V$, Over Drive=100mV, $C_L=15pF$, $T_a=25^\circ C$

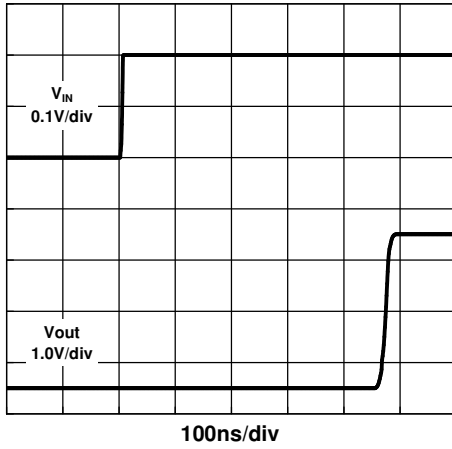

Propagation Delay t_{PHL}

$V_{DD}/V_{SS}=\pm 1.5V$, Over Drive=100mV, $C_L=15pF$, $T_a=25^\circ C$

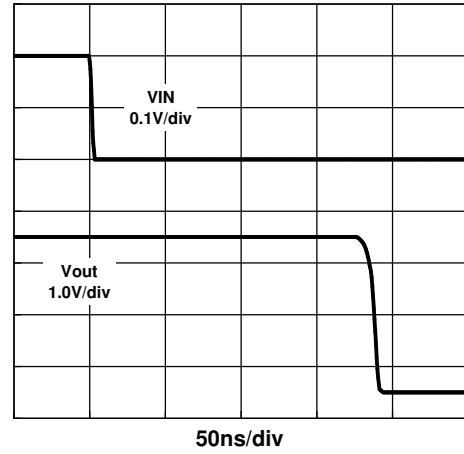

Propagation Delay vs. Temperature

$V_{DD}/V_{SS}=\pm 1.5V$, $V_{IN}=200mV_{pp}$, Over Drive=100mV, $C_L=15pF$

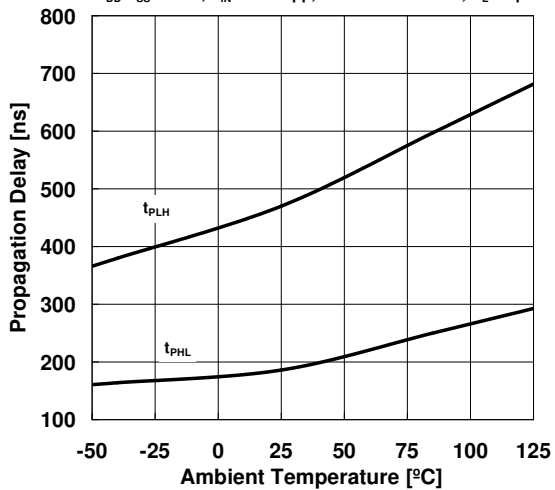

Propagation Delay vs. Supply Voltage

$V_{IN}=200mV_{pp}$, Over Drive=100mV, $C_L=15pF$, $T_a=25^\circ C$

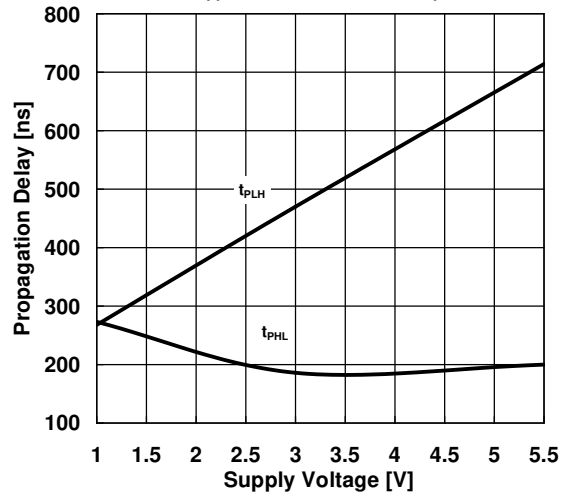

■ TEST CIRCUIT

Switching Characteristics Measurement Circuit

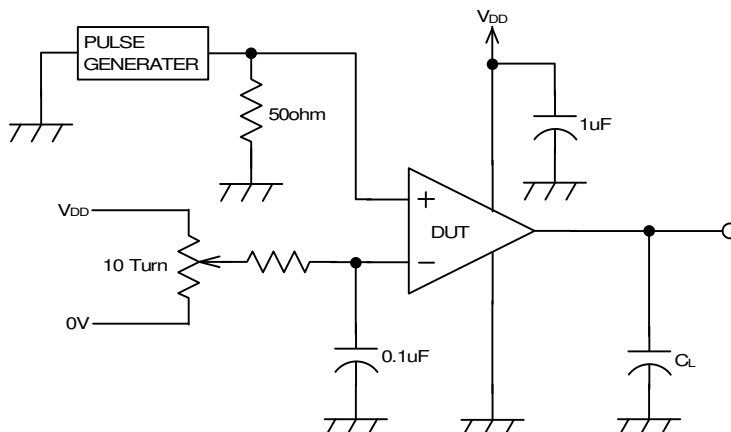

■PACKAGE DIMENSIONS

SC-88A

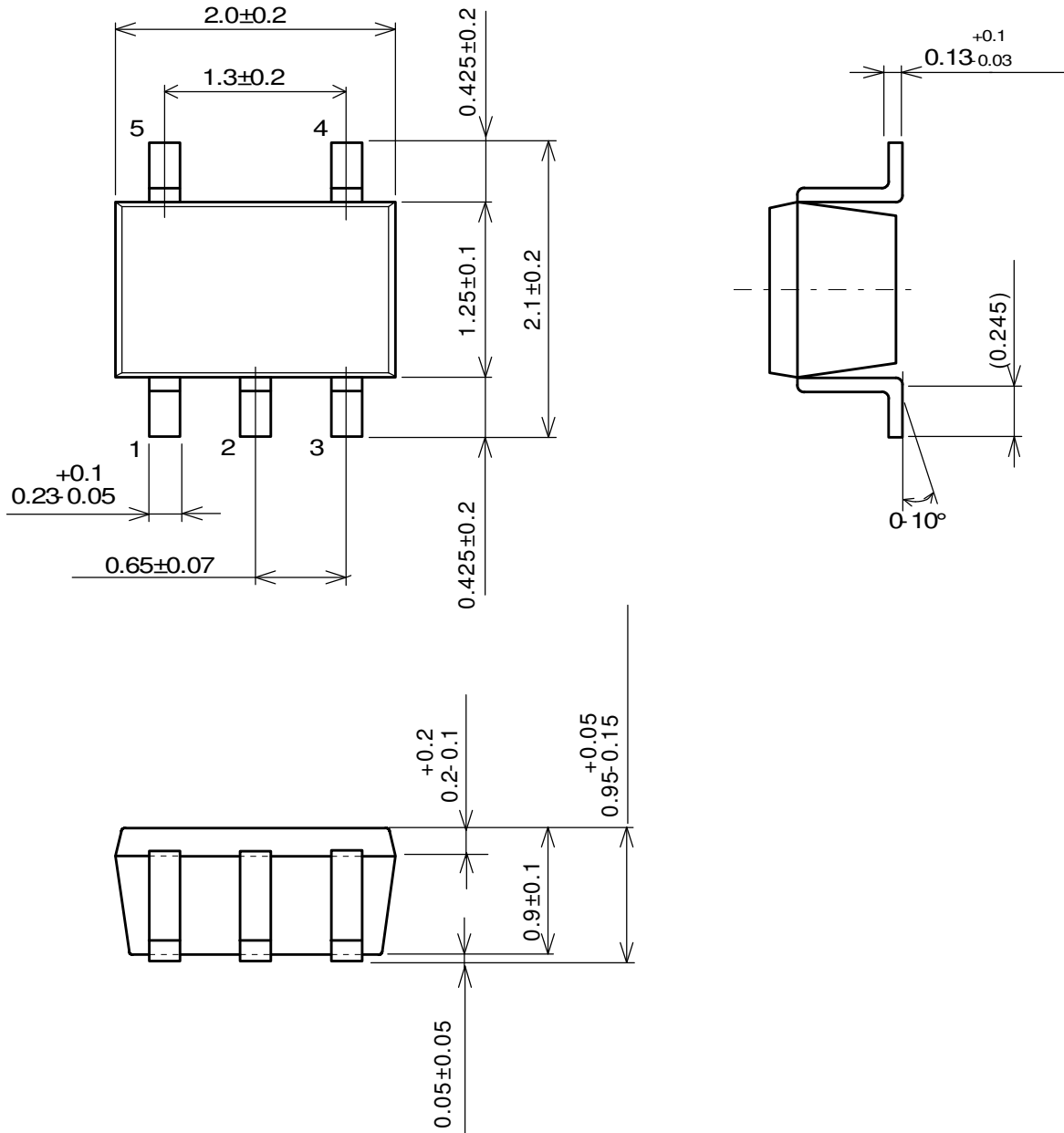

[CAUTION]
 The specifications on this data book are only given for information, without any guarantee as regards either mistakes or omissions. The application circuits in this data book are described only to show representative usages of the product and not intended for the guarantee or permission of any right including the industrial rights.