

THIS DRAWING IS UNPUBLISHED. RELEASED FOR PUBLICATION
 © COPYRIGHT BY TYCO ELECTRONICS CORPORATION. ALL RIGHTS RESERVED.

LOC		DIST		REVISIONS			
P	LTR	DESCRIPTION	DATE	DWN	APVD		
AD	00						
	A	ECO-07-000908	02JUL07	MB	MS		

INCH	MM
.004	0,10
.005	0,13
.010	0,25
.012	0,30
.039	1,00
.050	1,27
.059	1,50
.075	1,90
.118	3,00
.138	3,50
.170	4,32
.236	6,00

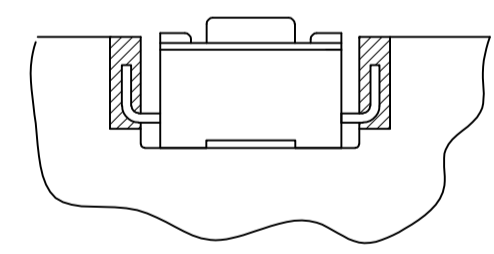
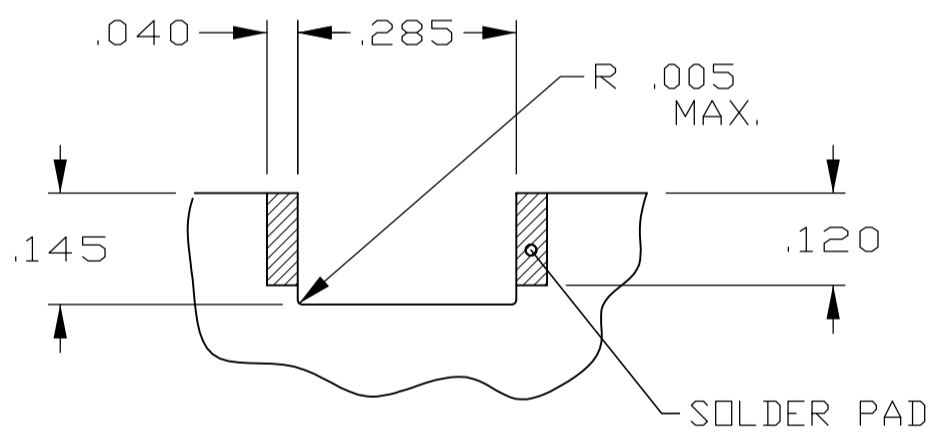
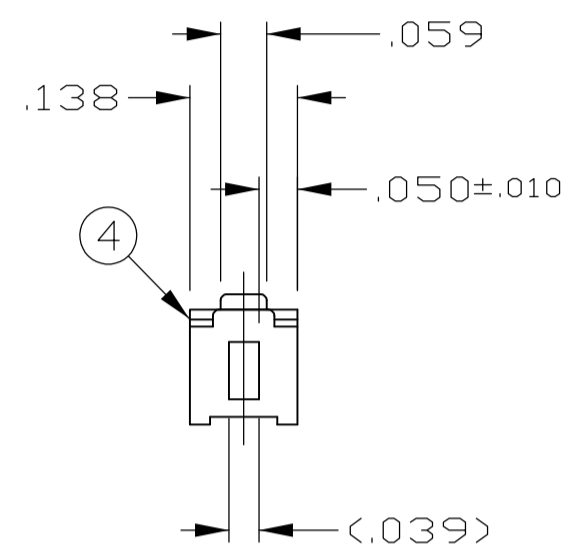
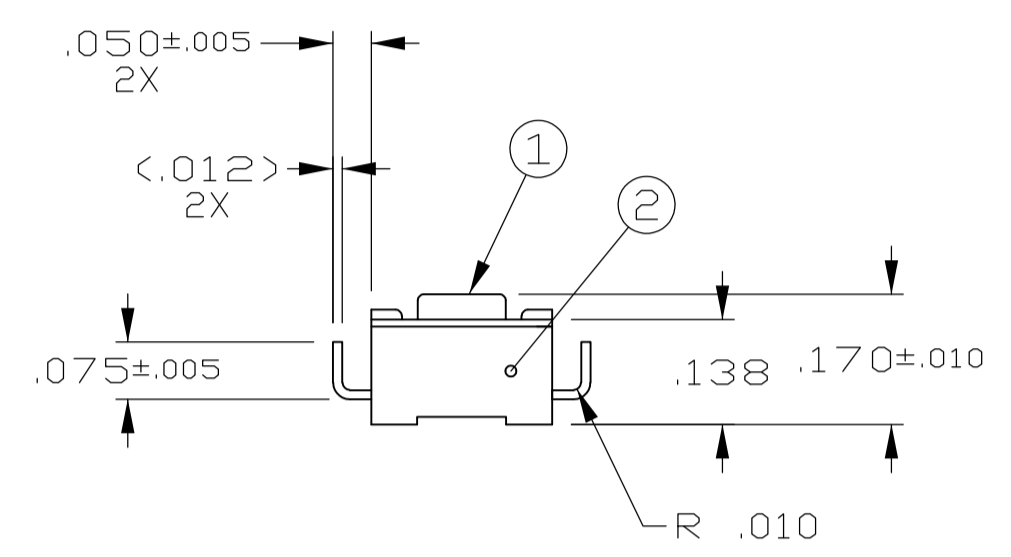
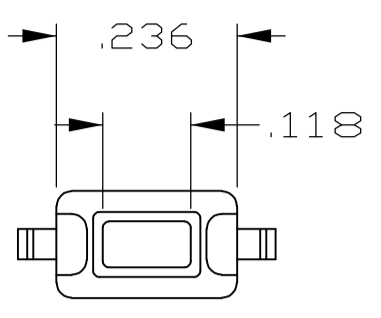

RECOMMENDED CUT-OUT FOOTPRINT

SPECIFICATIONS:

MATERIALS:
 CASE: NYLON 6/6, G30, 94HB, COLOR: NATURAL.
 COVER: STAINLESS STEEL.
 ACTUATOR BUTTON: NYLON 4/6, BLACK.
 MOVING CONTACT: 301 STAINLESS STEEL, 20μ" SILVER CLAD.
 FIXED CONTACT/TERMINAL: BRASS, 50μ" SILVER PLATE.

ELECTRICAL:
 MAX CONTACT RATING: 50MILLIAMPS@24V DC
 MIN CONTACT RATING: 10MICROAMPS@1V DC
 CONTACT RESISTANCE: 500 MILLIOHMS MAX.
 INSULATION RESISTANCE: 500 MEGOHMS MIN. @ 500 VDC.
 DIELECTRIC STRENGTH: 500 VAC.
 LIFE EXPECTANCY: 20,000 CYCLES MIN.

MECHANICAL:
 ACTUATION FORCE: 100 +60/-40 GRAMS.
 ACTUATION TRAVEL: .010 in. (0,25 mm).

ENVIRONMENTAL:
 OPERATING TEMPERATURE: -35°C TO +85°C
 STORAGE TEMPERATURE: -35°C TO +85°C
 RESISTANCE TO SOLDER HEAT PER 109-201, COND B

NOTES:

1. ALL MATERIALS AND FINISHES SHALL COMPLY WITH EU DIRECTIVE 2002/95/EC OF 27JAN2003 (ROHS)
2. SUBCONTRACTOR TO NOTE PART NUMBER, MANUFACTURING LOT NUMBER AND QUANTITY ON EACH PACKAGE.
3. PARTS TO BE COMMERCIALY FREE OF BURRS (MAX. OF 5% OF MATERIAL THICKNESS). NO LOOSE BURRS PERMITTED.
4. PARTS TO BE PACKAGED IN BAGS WITH 2,000 SWITCHES PER BAG.
5. PART NUMBER FSMJMTR IS PACKAGED IN TAPE AND REEL PER AIDSHEET DWG. 81082-01.
6. REEL AND CARRIER TAPE DWG, 11746.
7. COVER SEAL TAPE PART NO. 11747.
8. TAPE AND REEL PACKAGING MUST CONFORM TO AUGAT SPEC. 255.

THIS DRAWING IS A CONTROLLED DOCUMENT.		DWN M.BINNER 02JUL2007	Tyco Electronics Corporation Harrisburg, PA 17105-3608	
DIMENSIONS: INCHES		CHK M.SARVER 02JUL07	NAME FSMJM PUSHBUTTON SWITCH	
TOLERANCES UNLESS OTHERWISE SPECIFIED:		APVD M.SARVER 02JUL07	RESTRICTED TO	
0 PLC ± -		PRODUCT SPEC	SIZE A2	CAGE CODE 00779
1 PLC ± -		APPLICATION SPEC	DRAWING NO 8-1437565-2	SHEET 1 of 1
2 PLC ± -			SCALE 4:1	REV A
3 PLC ± .012				
4 PLC ± -				
ANGLES ± -				
FINISH		WEIGHT -		
MATERIAL -		CUSTOMER DRAWING		