

SJ100340
(DRAWING NO.)

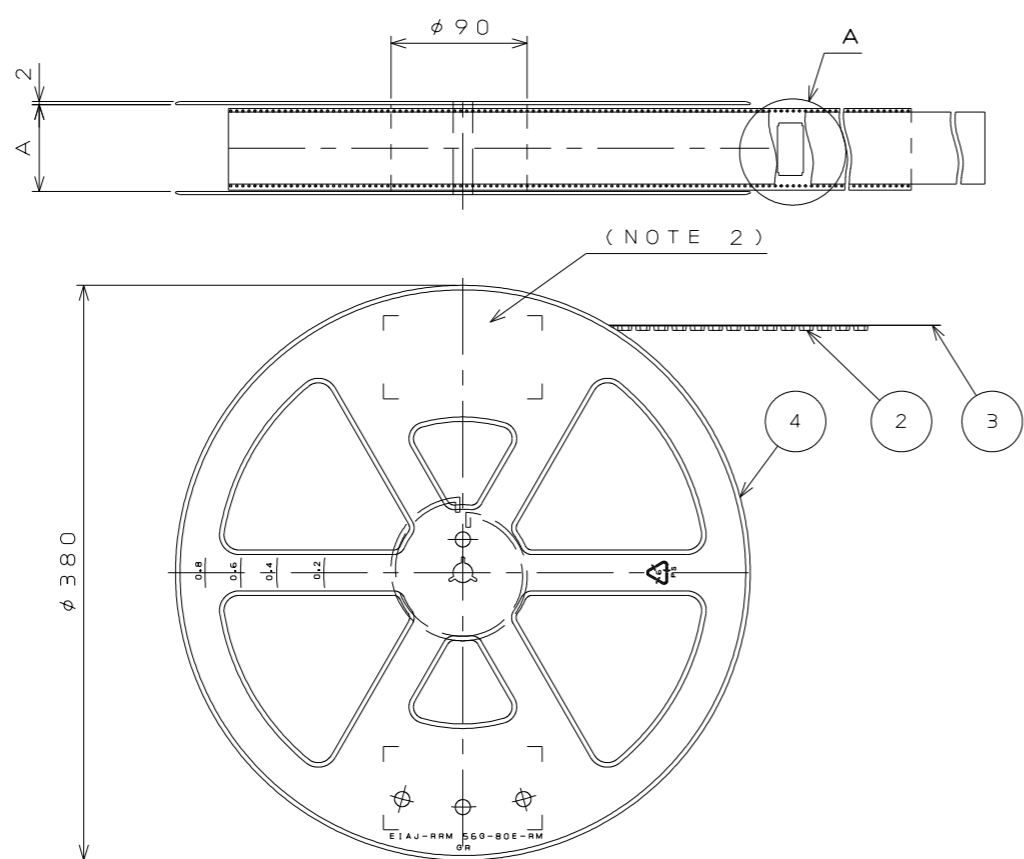

版数 VER.	年月日 DATE	CN NO.	変更内容 DESCRIPTION	製図 DR.	担当 CHK.	査閲 APPD.	承認 APPD.
2	10.Mar.2004	54574	REVISED TITLE, ETC		T.SHIODA	K.KAWASE	S.KASHIWAGI
3	1.Jul.2015	013743	CHANGED CARRIER TAPE MATERIAL	M.SAITOU	N.UCHIYAMA		T.KUDOU

TABLE 1

PART No.	A	B	C	D	E	F	CARRIER TAPE MATERIAL	CARRIER TAPE FORM
WR- 20P-VF-N1-R1500	18	16	7.5	—	8.3	0.4	PP.	TYPE II
WR- 30P-VF-N1-R1500	18	16	7.5	—	10.8	0.4	PP.	TYPE II
WR- 40P-VF-N1-R1500	26	24	11.5	—	13.3	0.4	PP.	TYPE II
WR- 50P-VF-N1-R1500	26	24	11.5	—	15.1	0.4	PP.	TYPE II
WR- 60P-VF-N1-R1500	26	24	11.5	—	18.3	0.4	PP.	TYPE II
WR- 70P-VF-N1-R1500	34	32	14.2	28.4	20.8	0.4	PP.	TYPE II
WR- 80P-VF-N1-R1500	34	32	14.2	28.4	22.6	0.4	PP.	TYPE II
WR-100P-VF-N1-R1500	46	44	20.2	40.4	27.7	0.4	PP.	TYPE II
WR-120P-VF-N1-R1500	46	44	20.2	40.4	32.6	0.4	PP.	TYPE II
WR-160P-VF-N1-R1500	58	56	26.2	52.4	43.3	0.5	PP.	TYPE II

DETAIL A
(SCALE 2:1)

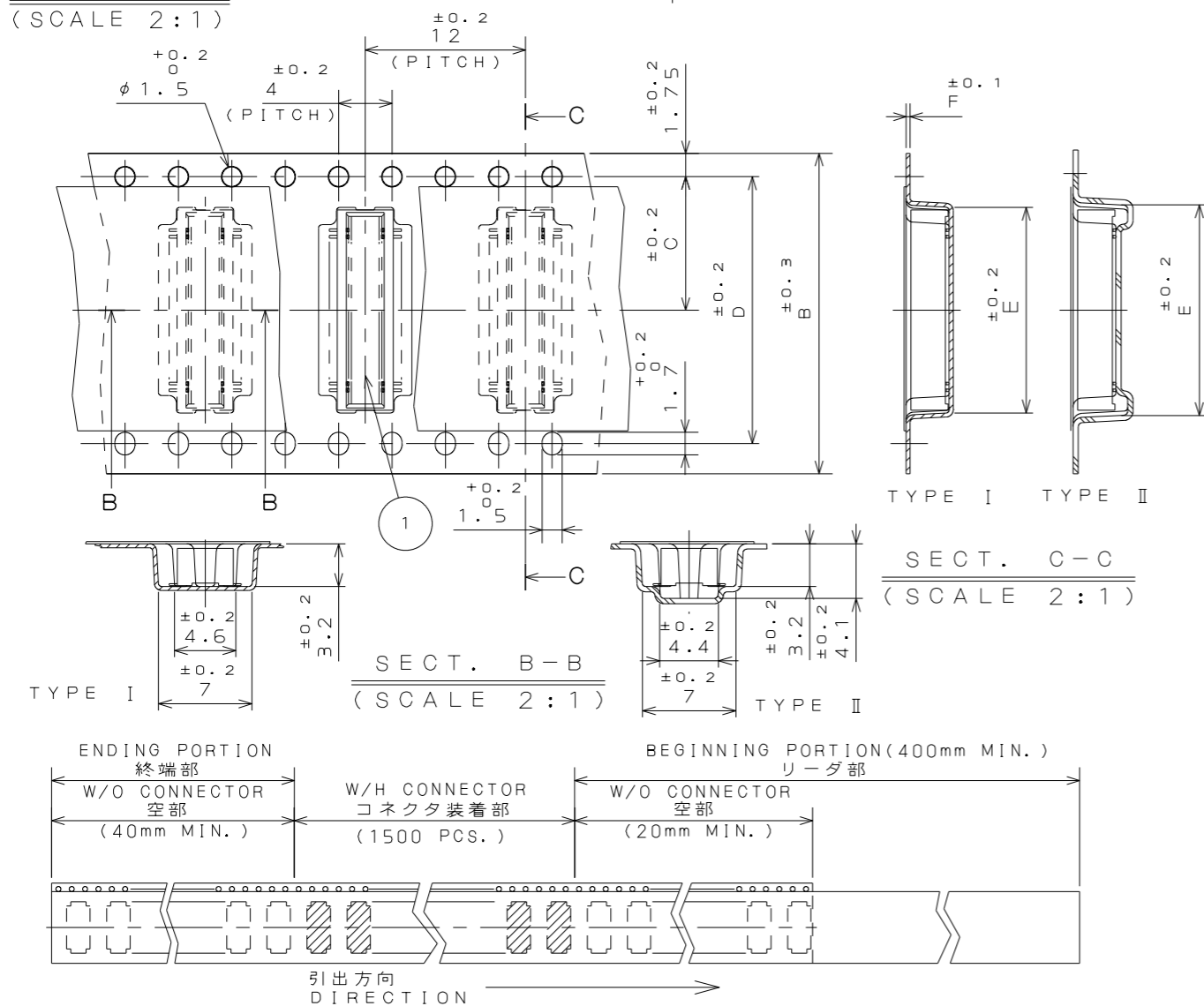

- NOTE1. SUFFIX "-R1500" OF PART NUMBER WR-*P-VF-N1-R1500 INDICATES 1500 PCS IN REEL.
 2. THE LABEL IN WHICH PART NO., NUMBER OF CONTACTS LOT NO., TAPE WIDTH AND FEED PITCH ARE MARKED, IS ATTACHED AS SHOWN.
 3. REFER TO THE DRAWING SJ100338(WR-*P-VF-N1) FOR CONNECTOR DIMENSION.
 4. IN CASE THAT DIMENSIONS B (TAPE WIDTH) IS 16mm 24mm, THERE IS PILOT HOLE AT ONE SIDE ONLY.
 5. CONTACT FINISH (TERMINAL AREA)

-VF-N1-R1500 GOLD FLASH OVER NICKEL

6. THE REEL SHAPE IN THIS DRAWING IS SUBJECT TO BE DIFFERENT FROM THE ACTUAL.

- "WR-*P-VF-N1-R1500"は 収納数1500個入りの リールに収納された 品名を表す。
- 図示の位置に 下記のシールを貼り、品名、収納数、ロットNo. 及びテープの幅と送りピッチを記入すること。
- コネクタ寸法は SJ100338(WR-*P-VF-N1)参照。
- B寸法(テープ幅)が16及び24の場合、パイロット穴は片側のみである。
- 品名に於て-VF-N1は端子部Ni上Auフラッシュメッキである。

現品ラベル/ARTICLE LABEL
 品名(DESCRIPTION) WR-*P-VF-N1-R1500
 図番(PART No.) SJ100340
 数量(Q'ty) 1.500
 ITEM NO *****
 Lot No. *****
 E.Code. TB2*2

2014/01/17
MADE IN JAPAN
JAE Japan Aviation Electronics Industry, Ltd.
QCF-C-0676(12.01)/JAPS-9006-2

4	PLASTIC REEL	—	PS. (RECYCLE)	—	—	—	—
3	COVER TAPE	—	PET.	—	—	—	—
2	CARRIER TAPE	—	TABLE 1	—	—	—	—
1	CONNECTOR	1500	—	—	—	—	WR-*P-VF-N1 SJ100338(NOTE 3)
符号 No.	名称 DESCRIPTION	個数 QTY.	材 料 MATERIAL	仕 上 FINISH	備 考 REMARKS		
仕様書 (SPECIFICATION)	第1版 (ORIGINAL DATE) 4.Dec.2003	尺 度 (SCALE)	シ リ ー ス (SERIES) WR	製 図 DR. M.TANAKA	日 本 航 空 電 子 工 業 株 式 有 限 公 司 JAPAN AVIATION ELECTRONICS INDUSTRY, LTD.	図面番号 (DRAWING NO.) SJ100340	
一般公差 (GENERAL TOLERANCE)	担 当 CHK. T.SHIODA	名 称 (TITLE) WR-*P-VF-N1-R1500	査 閲 APPD. K.KAWASE	認 可 APPD. S.KASHIWAGI	質 量 (MASS)	版 数 (VER.) 3	
寸 法 (DIMENSION)	角 度 (ANGLES)	単 位 (UNIT) : mm					
. ±0.8	×° ±						
.x ±0.4	×°x ±						
.xx ±0.1							
.xxx ±							