

THIS DRAWING IS UNPUBLISHED. RELEASED FOR PUBLICATION  
 © COPYRIGHT - By - ALL RIGHTS RESERVED.

LOC	DIST	REVISIONS					
AF	50	P	LTR	DESCRIPTION	DATE	DWN	APVD
		J1		REVISED PER ECR-19-018151	12NOV2020	AA	EW

- 1 CONTINUOUS STRIP ON REELS.
- 2 MATING TAB THK TO BE  $0.81 \pm 0.025$  [.032±.001].
- 3 WIRE SIZE IS #18-#14 AWG.
- 4 INSULATION RANGE IS 1.52-3.81 [.060-.150] DIA.
- 5 REEL WITH INTERLEAVING PAPER.
- 6 MATERIAL: BRASS
- 7 MATERIAL: HO4 PHOS BRZ
- 8 RECEPTACLE LENGTH CAN VARY UP TO 6.35 [.250] MAX, THIS SIDE ONLY.
- 9 PREPRODUCTION - FASR REQUIRED

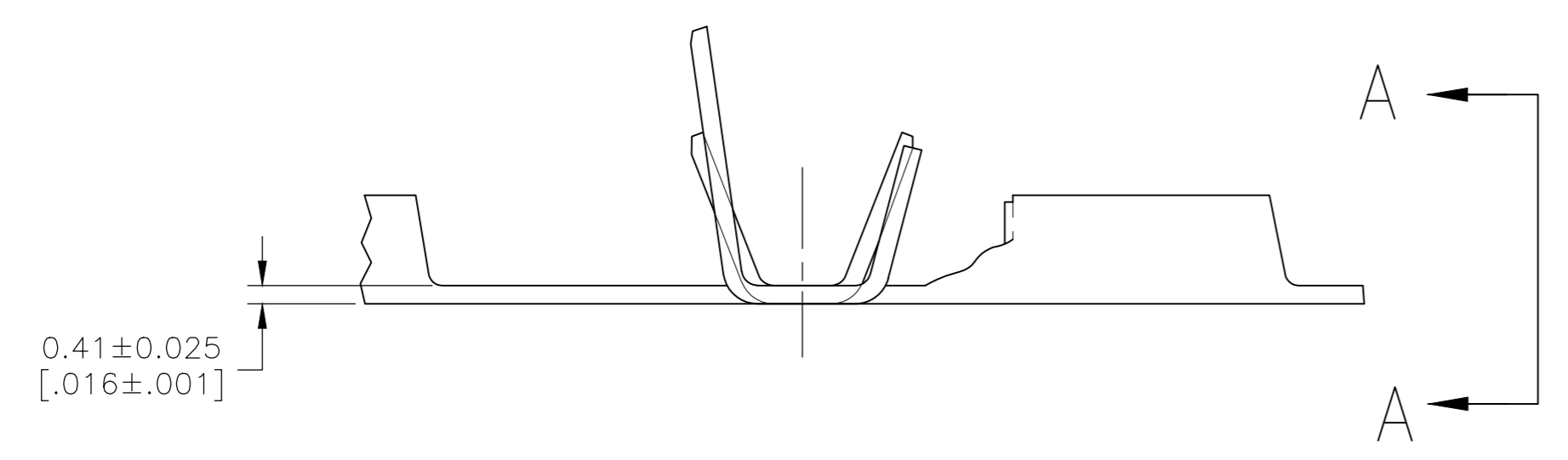
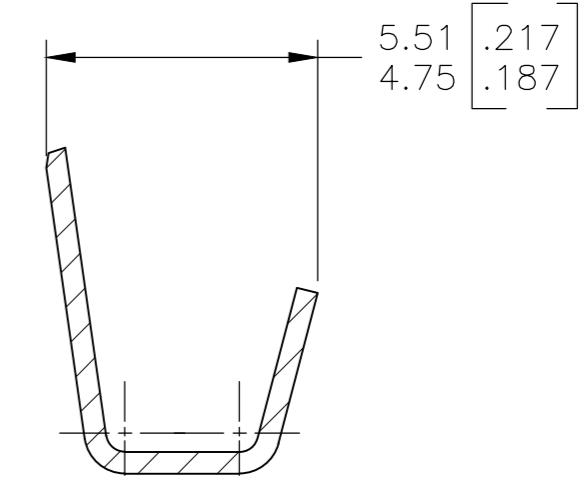
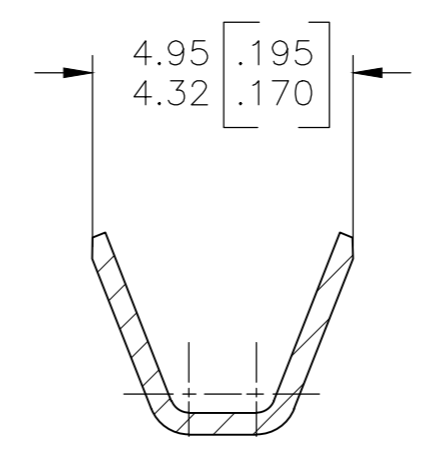
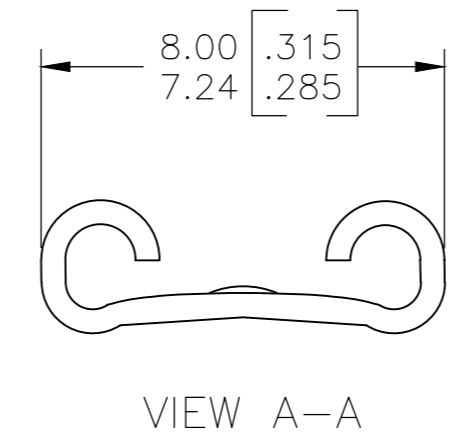
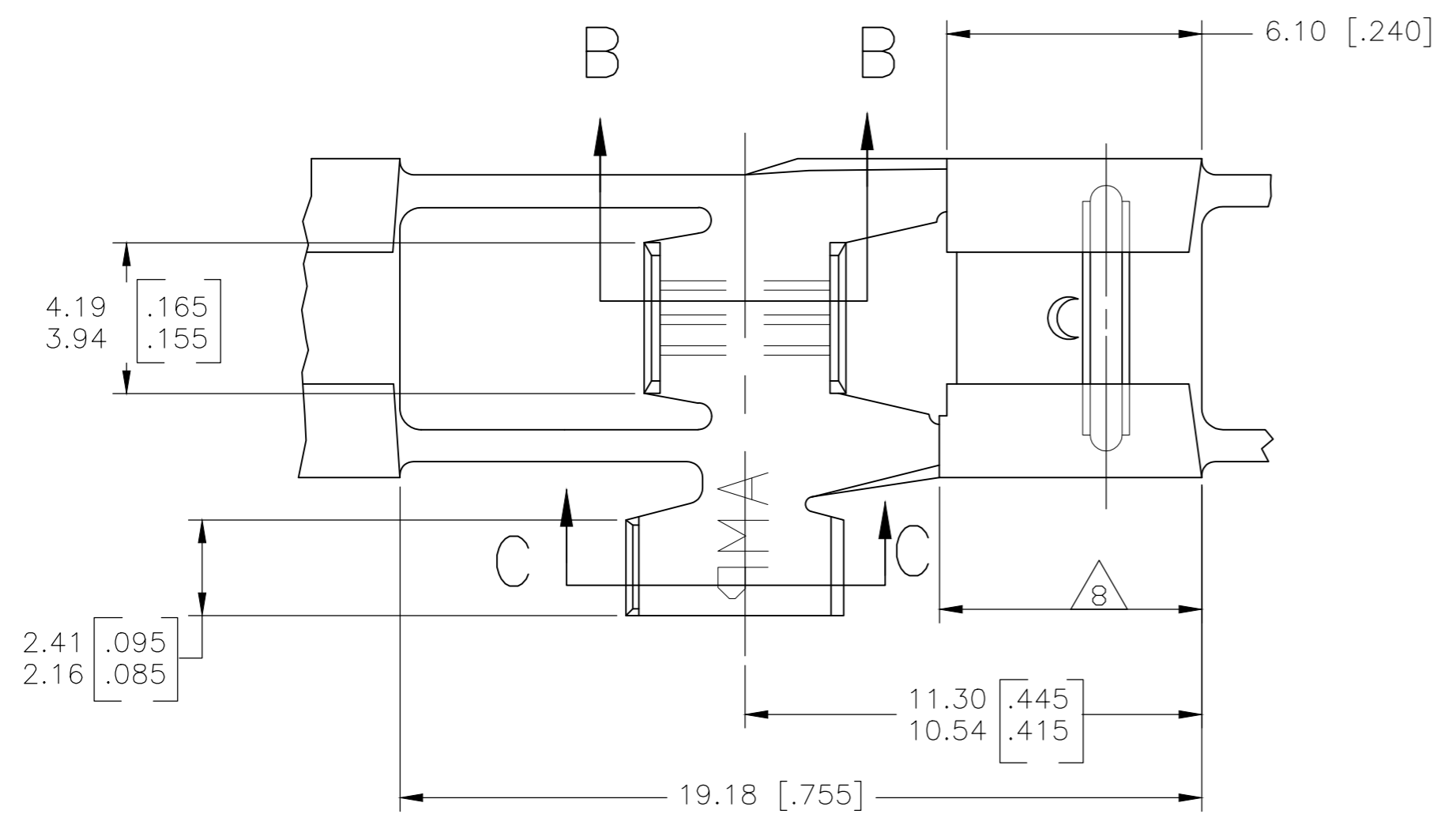

PART NO.	WIRE		INSULATION DIAMETER (MAX)	WIRE BARREL CRIMP			TENSILE STRENGTH POUNDS	
	QTY	SIZE AWG		WIDTH	CRIMP HEIGHT	CRIMPER		ANVIL
63314-1	1	14	.150	.120	.071	F	FLAT	50
	1	16			.063			30
	1	18			.057			20

5	OBSOLETE	7	SILVER	9	63314-5
	REVERSE REELED	6	TIN		63314-4
		6	TIN		63314-2
		6	-		63314-1
	MATERIAL		FINISH		PART NO.

THIS DRAWING IS A CONTROLLED DOCUMENT.

DWN	JR RUTH	6/16/87
CHK	MS FEHER	6/16/87
APVD	C MEYERS	6/16/87
PRODUCT SPEC		
APPLICATION SPEC		
WEIGHT	-	
CUSTOMER DRAWING		

TE Connectivity

RECEPTACLE, FLAG, FASTON, 6.35 [.250] SERIES

SIZE	A2	CAGE CODE	00779	DRAWING NO	C=63314	RESTRICTED TO	-
SCALE	7:1	SHEET	1 of 1	REV	J1		