

DO NOT
SCALE FROM
THIS PRINT

SERIES
-24: 2.4 MM

GENDER
-P: PLUG

TYPE
-C: CABLE

FINISH
-EP: 50µ" EXTRA HEAVY GOLD
CENTER CONTACT,
PASSIVATED OUTER CONTACT

TERMINATION
-S: SOLDER CLAMP

ORIENTATION
-S: STRAIGHT

CABLE TYPE
-160: SEMFLEX HP160

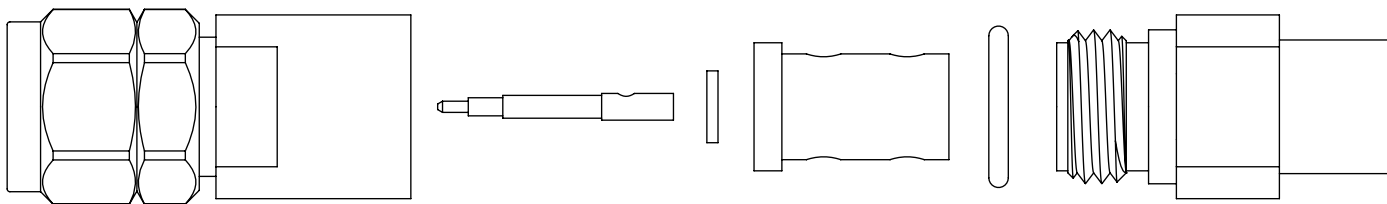
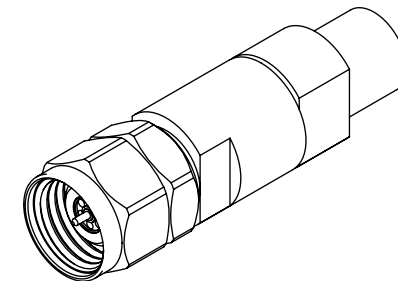
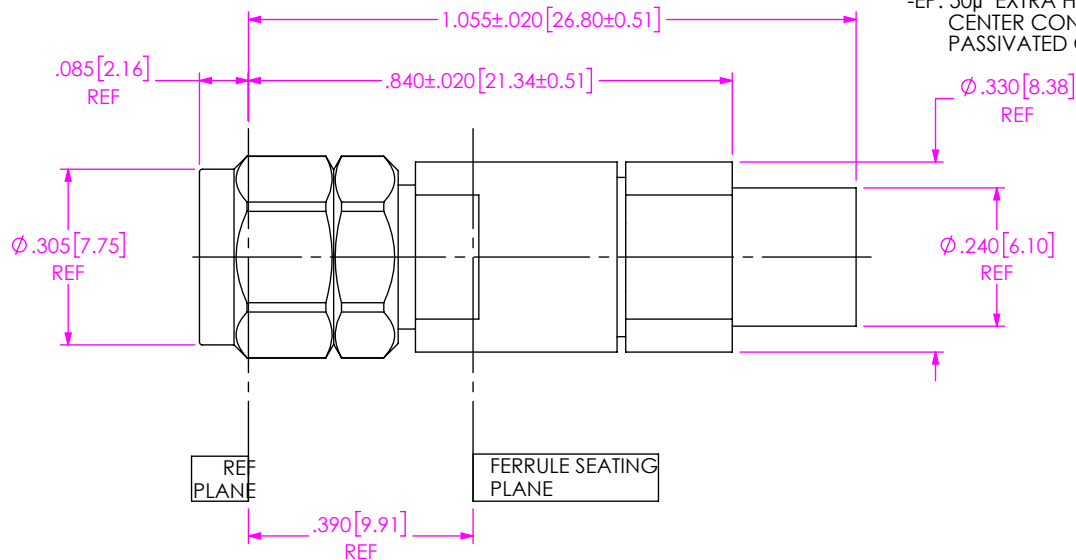

EXPLODED VIEW
NOT TO SCALE
(FOR CLARITY ONLY)

- NOTES:
- MATERIAL:
BODY, BUSHING, CLAMP NUT: STAINLESS STEEL.
GASKET & O-RING: SILICONE RUBBER.
BEAD: PPE.
DIELECTRIC STOP: ULTEM.
SOLDER FERRULE: BRASS ALLOY
CONTACT, LOCK RING: BERYLLIUM COPPER.

- FINISH:
BODY, BUSHING, CLAMP NUT: PASSIVATED.
CONTACT, SOLDER FERRULE: GOLD OVER NICKEL PLATE,
50 µIN MIN GOLD OVER 50 µIN MIN NICKEL.

3. PCI P/N: 3174.

UNLESS OTHERWISE SPECIFIED, DIMENSIONS ARE IN INCHES. TOLERANCES ARE: DECIMALS ANGLES .XX: ±.01 1° .XXX: ±.005 .XXXX: ±.0005	* PROPRIETARY NOTE * THIS DOCUMENT CONTAINS CONFIDENTIAL AND PROPRIETARY INFORMATION AND ALL DESIGN, MANUFACTURING, REPRODUCTION, USE, PATENT RIGHTS AND SALES RIGHTS ARE EXPRESSLY RESERVED BY SAMTEC, INC. THIS DOCUMENT SHALL NOT BE DISCLOSED, IN WHOLE OR PART, TO ANY UNAUTHORIZED PERSON OR ENTITY NOR REPRODUCED, TRANSFERRED OR INCORPORATED IN ANY OTHER PROJECT IN ANY MANNER WITHOUT THE EXPRESS WRITTEN CONSENT OF SAMTEC, INC.	 520 PARK EAST BLVD., NEW ALBANY, IN 47150 PHONE: 812-944-6733 FAX: 812-948-5047 e-Mail: info@SAMTEC.com code 55322
		DESCRIPTION: 2.4MM PLUG SOLDER CLAMP FOR SEMFLEX HP160 CABLE DWG. NO. PRF24-P-C-EP-160-SS BY: CHRISTIAN S. 04/30/2019 SHEET 1 OF 2

CABLE APPLICATION VIEWS

1A. TRIM CABLE TO EXPOSE DIELECTRIC CORE AND BRAIDS AS SHOWN.

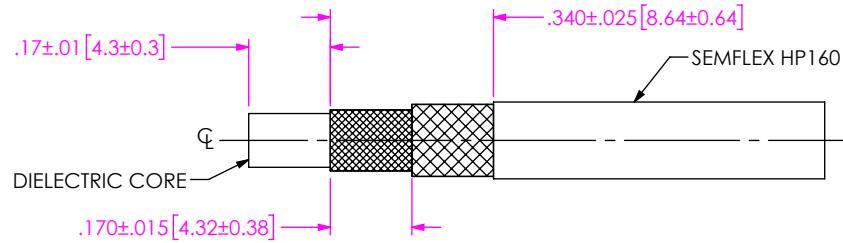

IN-PROCESS VIEW 1

2A. INSTALL O-RING ONTO CLAMP NUT AS SHOWN AND SLIDE CLAMP NUT OVER CABLE AS SHOWN.

2B. INSERT CABLE INTO SOLDER FERRULE UNTIL INNER BRAID IS SEATED AND SOLDER CABLE BRAIDS AS SHOWN.

2C. TRIM CABLE DIELECTRIC FLUSH WITH FACE OF SOLDER FERRULE.

2D. SLIDE DIELECTRIC STOP OVER CABLE CENTER CONDUCTOR AND SOLDER CONTACT FLUSH TO STOP TO DIM AS SHOWN.

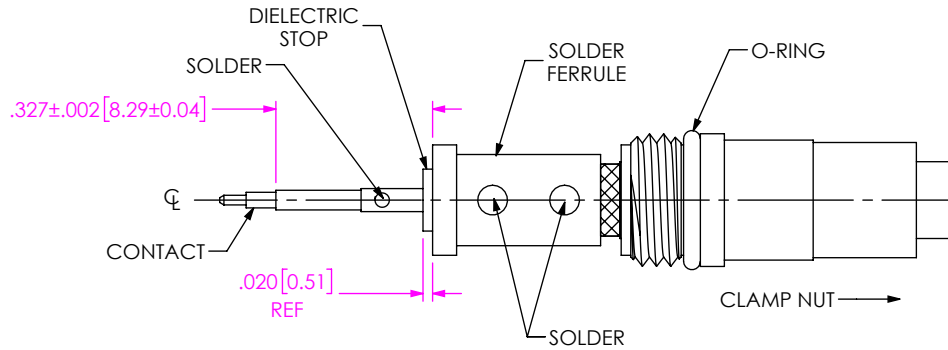

IN-PROCESS VIEW 2

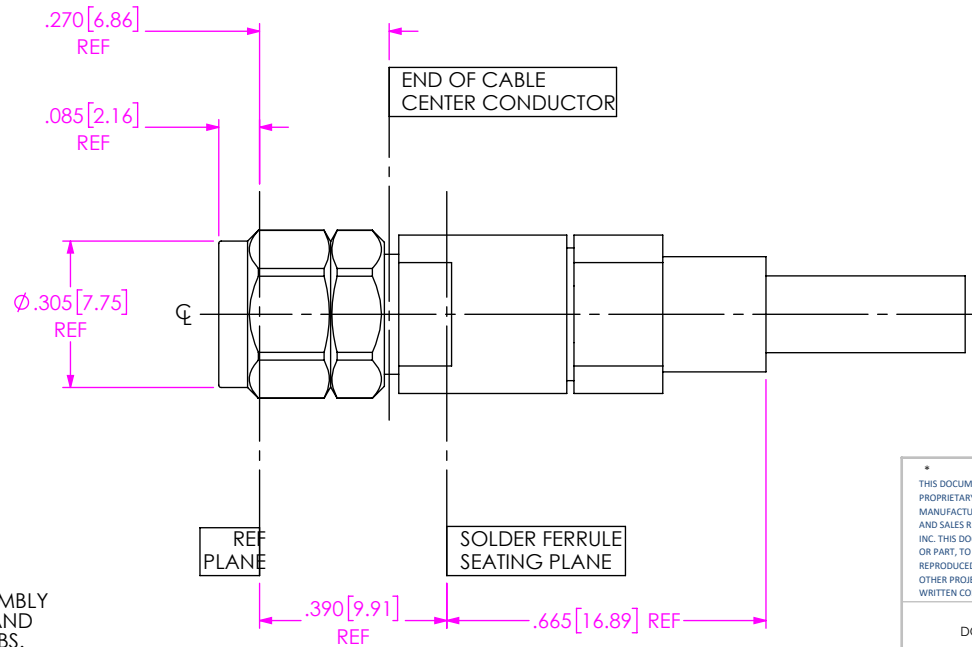

3A. INSERT CABLE/CONTACT SUB-ASSEMBLY INTO CONNECTOR UNTIL SEATED AND TIGHTEN CLAMP NUT TO 25-35 IN-LBS.

IN-PROCESS VIEW 3

PROPRIETARY NOTE
 THIS DOCUMENT CONTAINS CONFIDENTIAL AND PROPRIETARY INFORMATION AND ALL DESIGN, MANUFACTURING, REPRODUCTION, USE, PATENT RIGHTS AND SALES RIGHTS ARE EXPRESSLY RESERVED BY SAMTEC, INC. THIS DOCUMENT SHALL NOT BE DISCLOSED, IN WHOLE OR PART, TO ANY UNAUTHORIZED PERSON OR ENTITY NOR REPRODUCED, TRANSFERRED OR INCORPORATED IN ANY OTHER PROJECT IN ANY MANNER WITHOUT THE EXPRESS WRITTEN CONSENT OF SAMTEC, INC.



520 PARK EAST BLVD, NEW ALBANY, IN 47150
 PHONE: 812-944-6733 FAX: 812-948-5047
 e-Mail: info@SAMTEC.com code 55322

DO NOT SCALE DRAWING

SHEET SCALE: 4:1

DESCRIPTION: 2.4MM PLUG SOLDER CLAMP FOR SEMIFLEX HP160 CABLE

DWG. NO. PRF24-P-C-EP-160-SS

BY: CHRISTIAN S. 04/30/2019 SHEET 2 OF 2