

***Dolphin Frequency
Hopping Spread Spectrum
Evaluation Kit Hardware and Software***

User's Guide

IMPORTANT NOTICE

Texas Instruments Incorporated and its subsidiaries (TI) reserve the right to make corrections, modifications, enhancements, improvements, and other changes to its products and services at any time and to discontinue any product or service without notice. Customers should obtain the latest relevant information before placing orders and should verify that such information is current and complete. All products are sold subject to TI's terms and conditions of sale supplied at the time of order acknowledgment.

TI warrants performance of its hardware products to the specifications applicable at the time of sale in accordance with TI's standard warranty. Testing and other quality control techniques are used to the extent TI deems necessary to support this warranty. Except where mandated by government requirements, testing of all parameters of each product is not necessarily performed.

TI assumes no liability for applications assistance or customer product design. Customers are responsible for their products and applications using TI components. To minimize the risks associated with customer products and applications, customers should provide adequate design and operating safeguards.

TI does not warrant or represent that any license, either express or implied, is granted under any TI patent right, copyright, mask work right, or other TI intellectual property right relating to any combination, machine, or process in which TI products or services are used. Information published by TI regarding third-party products or services does not constitute a license from TI to use such products or services or a warranty or endorsement thereof. Use of such information may require a license from a third party under the patents or other intellectual property of the third party, or a license from TI under the patents or other intellectual property of TI.

Reproduction of information in TI data books or data sheets is permissible only if reproduction is without alteration and is accompanied by all associated warranties, conditions, limitations, and notices. Reproduction of this information with alteration is an unfair and deceptive business practice. TI is not responsible or liable for such altered documentation.

Resale of TI products or services with statements different from or beyond the parameters stated by TI for that product or service voids all express and any implied warranties for the associated TI product or service and is an unfair and deceptive business practice. TI is not responsible or liable for any such statements.

Following are URLs where you can obtain information on other Texas Instruments products and application solutions:

Products		Applications	
Amplifiers	amplifier.ti.com	Audio	www.ti.com/audio
Data Converters	dataconverter.ti.com	Automotive	www.ti.com/automotive
DSP	dsp.ti.com	Broadband	www.ti.com/broadband
Interface	interface.ti.com	Digital Control	www.ti.com/digitalcontrol
Logic	logic.ti.com	Military	www.ti.com/military
Power Mgmt	power.ti.com	Optical Networking	www.ti.com/opticalnetwork
Microcontrollers	microcontroller.ti.com	Security	www.ti.com/security
		Telephony	www.ti.com/telephony
		Video & Imaging	www.ti.com/video
		Wireless	www.ti.com/wireless

Mailing Address: Texas Instruments
Post Office Box 655303 Dallas, Texas 75265

Read This First

About This Manual

This document presents the contents of the Dolphin frequency hopping spread spectrum (FHSS) wireless UART demonstration and development tool kit. The Dolphin chipset consists of the TRF6903 RF transceiver and the DBB03A baseband ASIC. The term Dolphin will be used in the rest of the document.

The user manual provides information on how to operate the Dolphin demo kit and describes its hardware and software. Users should understand the DBB03A baseband ASIC and the TRF6903 to obtain the full benefit of this user manual.

How to Use This Manual

Different topics covered in this manual may require different levels of expertise. The first chapter gives an overview of the kit. The second and third chapters focus on how to use the kit and get started on the development. The fourth and fifth chapters focus on the hardware and software details of the Dolphin demo kit respectively. The frequency hopping protocol details are presented in Chapter 5 and Chapter 6 demonstrates applications and architectures that could use Dolphin.

Chapter 1 – Evaluation Kit Overview

Chapter 2 – Demonstrating a Wireless Link

Chapter 3 – PCB Hardware

Chapter 4 – Software

Chapter 5 – Protocol and Firmware Overview

Chapter 6 – Applications

Appendix A – RF Test Reports

Appendix B – FCC Prescan Documents

Appendix C – Range Results

Related Documentation From Texas Instruments

Other related Texas Instruments documents that may be helpful are:

- TRF6903 data sheet – SWRS022
- DBB03A data sheet – SWRS030
- TRF6903 design guide – SWRU009
- TRF6903 FAQ
- Interfacing Dolphin to an External System Microcontroller application note – SWRA045
- Dolphin Frequency Hopping Spread Spectrum Chipset Host Interface Protocol application note – SWRA043

Product Websites

For design and product information related to the TRF6903 and similar products, go to:

- <http://www.ti.com/ismrf>
- PDF documents and zip files may be located on Texas Instruments' website by typing in the literature number in the *Search* text box; for example, typing in SWRS022 locates the TRF6903 data sheet.

FCC Warning

This equipment is intended for use in a laboratory test environment only. It generates radio frequency (RF) energy and has not been tested for compliance within the limits of computing devices pursuant to Subpart J, Part 15 of United States FCC regulations, which are designed to provide reasonable protection against radio frequency interference. Operation of this equipment in other environments may cause interference with radio communications, in which case the user (at their own expense) will be required to take whatever measures may be required to correct this interference.

Disclaimer

Please note that the enclosed demonstration boards are experimental printed circuit boards and are therefore only intended for device demonstration and evaluation.

The circuit boards have been manufactured by one or more of Texas Instruments' external subcontractors which may not be production qualified. Device parameters that are measured with these circuit boards may not be representative of production devices or typical production data. Texas Instruments does not represent or guarantee that a final hardware version will be made available after device evaluation.

THE DEMONSTRATION CIRCUIT BOARDS ARE SUPPLIED WITHOUT WARRANTY OF ANY KIND, EXPRESSED, IMPLIED OR STATUTORY, INCLUDING BUT NOT LIMITED TO, ANY IMPLIED WARRANTY OF MERCHANTABILITY OR FITNESS FOR A PARTICULAR PURPOSE. TEXAS INSTRUMENTS ACCEPTS NO LIABILITY WHATSOEVER ARISING AS A RESULT OF THE USE OF THESE CIRCUIT BOARDS.

The fee associated with the demonstration boards is a nonrecurring engineering fee (NRE) to partially defray the engineering costs associated with circuit board development and applications support for the integrated circuit semiconductor product(s). The circuit board is a tool for demonstrating and evaluating the RF semiconductors supplied by Texas Instruments. The demonstration board is supplied to prospective customers to provide services and software that will help them to evaluate the RF semiconductors.

The demonstration board may be operated only for product demonstration or evaluation purposes and then only in nonresidential areas. Texas Instruments' understanding is that the customer's products using the RF parts listed shall be designed to comply with all applicable FCC and appropriate regulatory agency requirements and will, upon testing, comply with these requirements. Operation of this device is subject to the conditions that it does not cause harmful interference and that it must accept any interference.



Contents

1	Dolphin Demonstration and Evaluation Kit Overview	1-1
1.1	Description of Dolphin Chipset	1-2
1.2	Dolphin Chipset vs Dolphin Demo Kit	1-3
1.3	Dolphin Features	1-4
1.4	Low Power and High Power Chipset Solutions	1-4
1.5	Evaluation Software	1-5
1.6	Contents	1-6
1.7	Equipment Requirement	1-6
2	Demonstrating a Wireless Link	2-1
2.1	Board Description	2-2
2.2	Operational Overview	2-4
2.2.1	Preparing for Operation	2-4
2.2.2	Power Up	2-4
2.2.3	Wireless Demonstration – Link Mode	2-4
2.2.4	Test Mode	2-6
2.2.5	Error Conditions	2-6
3	PCB Hardware Overview	3-1
3.1	Hardware Overview	3-2
3.1.1	TRF6903 Block Diagram	3-3
3.1.2	DBB03A Block Diagram	3-4
3.2	Low Power Version	3-5
3.2.1	Overview	3-5
3.2.2	Schematics	3-6
3.2.3	Top and Bottom Side of the LP Board	3-7
3.2.4	BOM for the LP Version	3-9
3.3	High Power Version	3-12
3.3.1	Overview	3-12
3.3.2	Schematics	3-14
3.3.3	Different Layers of the HP Board	3-15
3.3.4	BOM for the HP Version	3-17
3.4	Other Hardware Features	3-20
3.4.1	Dolphin Interface Board	3-20
3.4.2	Antenna and RF Shield	3-22
3.4.3	Discrete LC Filter for Harmonic Suppression	3-22
3.4.4	IF Filter	3-23
3.4.5	Ceramic Discriminator	3-24
3.4.6	TR Switch	3-25

3.4.7	External Crystal for the TRF6903	3-25
4	Software Overview	4-1
4.1	Software Description	4-2
4.2	Software Setup	4-3
4.2.1	Setting Device Identification	4-4
4.2.2	RF Settings	4-4
4.2.3	Statistics	4-5
4.2.4	Test Settings	4-7
4.2.5	Communication Settings	4-9
4.3	Setting Up and Testing a Wireless Link	4-10
4.3.1	Single-Ended Test	4-10
4.3.2	Round Trip Test	4-12
4.3.3	Single Transmissions	4-13
4.3.4	Save Communication Log to a File	4-14
5	Protocol and Firmware Overview	5-1
5.1	Protocol Overview	5-2
5.1.1	RF Transmit / Receive Protocol Overview	5-2
5.1.2	RF Transmit Logic Diagram	5-3
5.1.3	RF Receive Logic Diagram	5-5
5.2	Firmware Overview	5-6
5.2.1	Implementation of Frequency-Hopping Protocol	5-6
6	Applications	6-1
6.1	Network Architecture	6-2
6.1.1	Point-Point Architecture	6-2
6.1.2	Broadcast Architecture	6-4
6.2	Applications	6-4
6.2.1	Wireless Metering – AMR	6-4
A	RF Test Reports	A-1
A.1	RF Test Report for the Low-Power Board	A-2
A.2	RF Test Report for the High-Power Board	A-3
B	FCC Prescan Results	B-1
B.1	Low-Power Board FCC Prescan Results	B-2
B.1.1	SUMMARY	B-2
B.1.2	SETUP	B-2
B.1.3	RESULTS	B-2
B.2	High Power Board FCC Prescan Results	B-3
B.2.1	SUMMARY	B-3
B.2.2	SETUP	B-3
B.2.3	RESULTS	B-4
C	Range Tests	C-1
C.1	Low-Power Board Range Results	C-2
C.2	High-Power Board Range Results	C-3
D	Dolphin Bit Rate (Data Rate) Vs Throughput	D-1
C.1	Dolphin Bit Rate (Data Rate Versus Throughput)	D-2

Figures

1-1	Dolphin Chipset Architecture	1-2
1-2	Dolphin Demo Kit	1-3
1-3	Evaluation Using Software	1-5
2-1	Top Side of the Demonstration Board	2-2
2-2	Top Side of the Serial Interface Board	2-3
2-3	Link Mode Demonstration	2-5
3-1	TRF6903 Block Diagram	3-3
3-2	DBB03A Block Diagram	3-4
3-3	Dolphin Low Power Board	3-5
3-4	Low Power Board Schematic	3-6
3-5	Top Side (LP Version)	3-7
3-6	Bottom Side (LP Version)	3-8
3-7	High Power (HP) Board	3-13
3-8	HP Board Schematic	3-14
3-9	Top Layer and Layer 2 (HP Version)	3-15
3-10	Bottom Layer and Layer 3 (HP Version)	3-16
3-11	Dolphin Interface Board Schematic	3-21
3-12	Top-Side Assembly of the Interface Board	3-22
3-13	Discrete LC Filter	3-23
3-14	Recommended IF Filter Response	3-24
3-15	Murata Ceramic Discriminator – Frequency Characteristics	3-25
4-1	Evaluation Software– Main Screen	4-2
4-2	Communication Setup Screen Under Settings Pull Down Menu	4-3
4-3	RF Settings Screen	4-5
4-4	Statistics Settings Screen	4-6
4-5	Test Settings Screen	4-7
4-6	Test Settings Transmit Mode	4-8
4-7	Test Settings Receive Mode	4-9
4-8	Transceiver Bit Rate Settings Screen	4-10
4-9	ID Setup for Single-Ended Link Test	4-12
4-10	ID Setup for Round-Trip Test	4-13
4-11	Enabling the Save Log To File Option	4-15
4-12	Saving the Log File	4-16
5-1	RF Overhead in Hop Mode	5-2
5-2	RF Overhead in Single-Channel Mode	5-3
5-3	Transmit-Side Logic Diagram	5-4
5-4	Receive-Side Logic Diagram	5-5
5-5	Protocol Overview	5-6
6-1	Star Topology	6-2

6-2	Ring Topology	6-3
6-3	Complete Topology	6-3
6-4	Broadcast Topology	6-4
6-5	Overview of the AMR System	6-5
6-6	Wireless Metering (AMR) Application Using Dolphin Wireless	6-6
C-1	Low-Power Board – Outdoor Range Results	C-2
C-2	High-Power Board – Outdoor Range Results	C-3

Tables

3-1	Initial System Design Specifications	3-2
3-2	Low Power (LP) Board Performance Summary	3-5
3-3	HP Board Performance	3-13
3-4	Murata IF Filter SF ECS10M7EA00-R0	3-23
3-5	Murata Ceramic Discriminator CDSCB10M7GA119-R0	3-24
3-6	Example Crystal Information: Crystek 017119	3-25
B-1	Fundamental Emissions: (15.249 limit = 94 dBmV/m)	B-3
B-2	FCC Part 15.247 – Maximum Power (A = 0 dB)	B-3
B-3	FCC Part 15.249 – Minimum Power (A = 20 dB)	B-3
B-4	FCC Part 15.247 – Transmit Mode, Maximum Power (A = 0 dB)	B-4
C-1	Range Test Results	C-1

Dolphin Demonstration and Evaluation Kit Overview

This chapter provides an overview of the Dolphin demonstration and development kit.

Topic	Page
1.1 Description of Dolphin Chipset	1-2
1.2 Dolphin Chipset vs Dolphin Demo Kit	1-3
1.3 Dolphin Features	1-4
1.4 Low Power and High Power Chipset Solutions	1-4
1.5 Evaluation Software	1-5
1.6 Contents	1-6
1.7 Equipment Requirement	1-6

1.1 Description of Dolphin Chipset

The Dolphin is a frequency hopping wireless universal asynchronous receiver/transmitter (UART) chipset solution and can be used to implement a wireless link that end applications can interface to as a peripheral, shielding the end-application from the implementation details. The Dolphin chipset solution eases wireless system development while keeping the end application highly integrated and flexible.

The Dolphin is a FCC pre-certified reference design and the chipset solution consists of a Texas Instruments TRF6903 single-chip multi-band RF transceiver and a digital baseband ASIC (DBB03A) with frequency hopping firmware residing on its ROM-based program memory.

The DBB03A can be controlled through an external evaluation software or system microcontroller through the hardware UART interface of the DBB03A. This is illustrated in Figure 1–1. For further details on the interfacing system micro to the Dolphin chipset and example firmware, see the application note SWRA045.

Figure 1–1. Dolphin Chipset Architecture

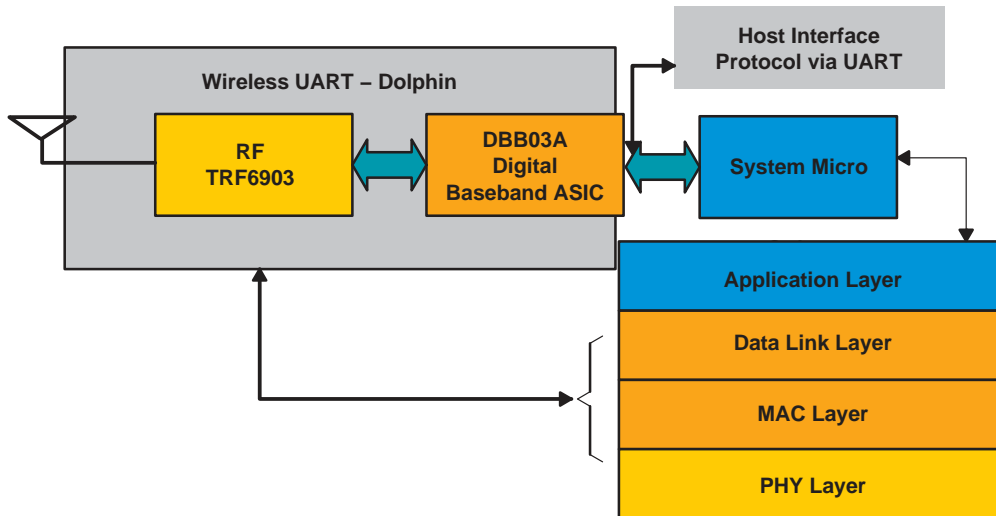

Note: See the DBB03A data sheet (SWRS030) for information on how to order these ROM-coded parts.

1.2 Dolphin Chipset vs Dolphin Demo Kit

It is important to understand the difference between Dolphin chipset and the Dolphin demo kit.

- ❑ The Dolphin demo kit as name indicates is used for demonstration/evaluation purposes and consists of a TRF6903 RF transceiver and the DBB03A digital baseband ASIC. For demo purposes, Texas Instruments provides software to evaluate Dolphin. This evaluation software interfaces with the DBB03A via UART as shown in Figure 1–2.

Figure 1–2. Dolphin Demo Kit

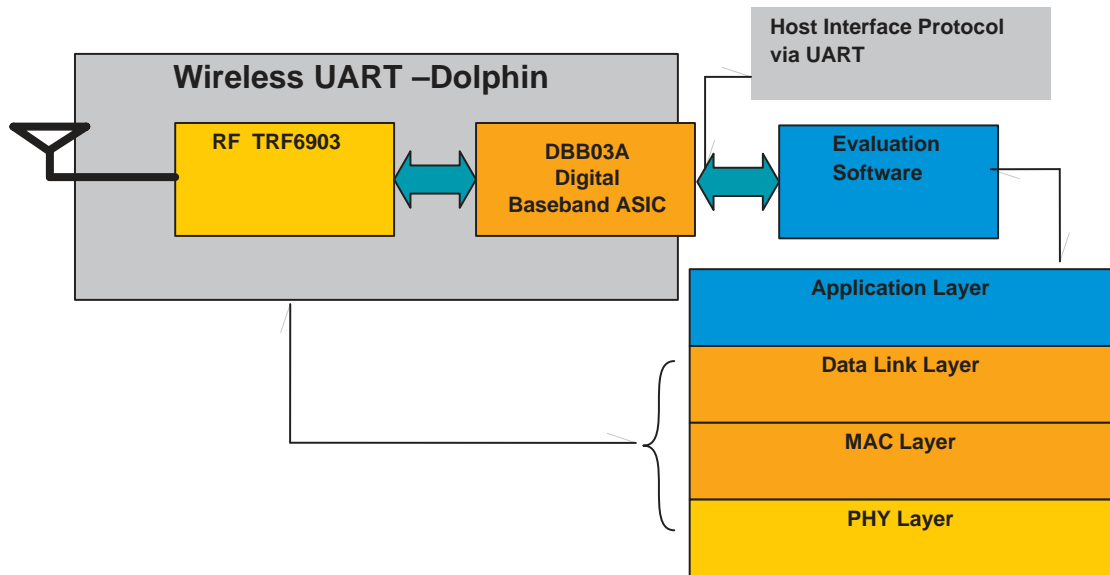

- ❑ See the <http://www.ti.com/ismrf> website for information on how to obtain the Dolphin demo kits.
- ❑ However in end-user applications, an external host/system microcontroller is needed to interface with the Dolphin. This is the Dolphin Chipset and is shown in Figure 1–1.

1.3 Dolphin Features

The end-system can treat Dolphin as a peripheral capable of establishing a wireless link. The system microcontroller focuses on the end application level protocol. Any catalog microcontroller can be used as a system microcontroller which provides added flexibility. The interface between the system microcontroller and the DBB03A digital baseband ASIC is a simple UART. The Dolphin demo kit has been provided with evaluation software that communicates with the DBB03A using a UART interface that follows a defined protocol. This host interface protocol document is detailed in *Dolphin Host Interface Protocol Definition* application report (SWRA043). The DBB03A digital baseband ASIC contains the frequency hopping firmware and handles the wireless communication protocols in the MAC and data link layer.

The Dolphin demo kit is used to demonstrate a FCC compliant (Sec 15.247) frequency hopping spread spectrum (FHSS) wireless data link. The firmware resides on the DBB03A device and supports point-point, broadcast networks with acknowledgement and retries. The reference design (schematics and layout of the board) has been FCC precertified and can be used to ramp up the FCC certification process and lower system development hurdles.

1.4 Low Power and High Power Chipset Solutions

The Dolphin chipset solution is offered in two versions; low power (LP) and high power (HP). The low-power version generates an output power of +7 dBm, while the high-power version generated an output power of +23 dBm (at $V_{CC} = 3.6\text{ V}$) and +20 dBm (at $V_{CC} = 3\text{ V}$) using an external PA.

Both LP and HP versions of the Dolphin demo kit are offered for evaluation. The Dolphin demo kit provides an option to be powered from either a 3-V battery or from an external dc-power supply.

Both the LP and HP designs are FCC precertified. For hardware descriptions of low-power and high-power versions, see Chapter 3. The schematics, Gerber's, and BOM for both low-power and high-power versions can be downloaded from the <http://www.ti.com/ismrf> website.

1.5 Evaluation Software

Texas Instruments provides software to evaluate the performance of the Dolphin demo kit. This software interfaces to the DBB03A using a simple UART. This is shown in Figure 1–3. A protocol has been developed to establish communication between any external evaluation software (or system microcontroller) and the DBB03A. This is called *Dolphin Host Interface Protocol* and is documented in detail in application report SWRA043.

Figure 1–3. Evaluation Using Software

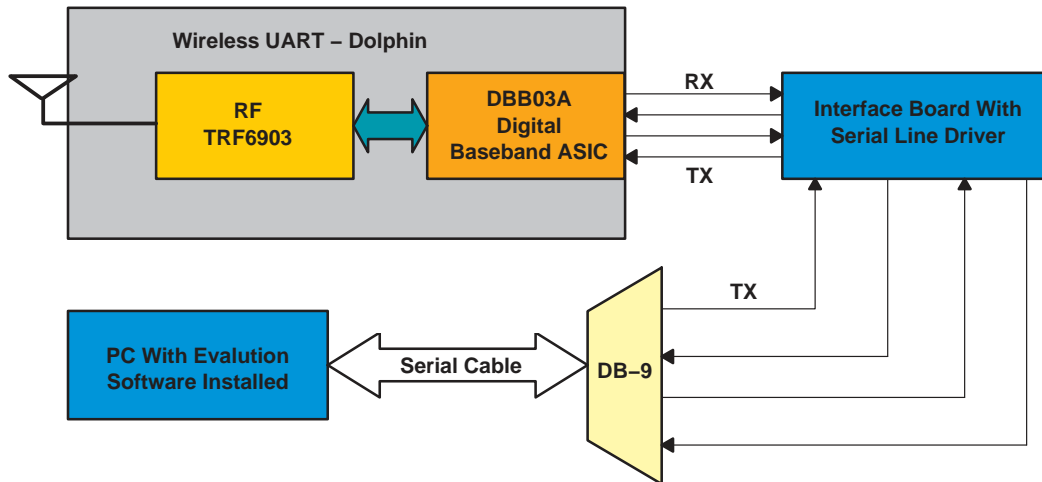

The evaluation software is dealt in detail in Chapter 4. The important features provided by the evaluation software are:

- Single channel / frequency hopping mode of operation selection
- Enable acknowledgement / retries for reliable data transfer
- Programmable transceiver baud rate and serial port baud rate selection
- Test mode selection
- Packet error rate statistics with and without retries
- Save / retrieve communications log to/from a file
- ACSII / hex message transfer and reception

1.6 Contents

The Dolphin demonstration and development kit contains:

- Two Dolphin (TRF6903 + DBB03A) demonstration boards
- User's manual (this document)
- Two interface boards (to connect Dolphin demonstration boards to computers)
- Host Protocol interface software
- TRF6903 and DBB03A data sheets
- Two serial port cables

The part numbers of the demonstration and development kit are as follows:

- DOLPHIN-LP-EVM for the low-power Dolphin kit.
- DOLPHIN-HP-EVM for the high-power Dolphin kit.

In order to demonstrate the broadcast capability of the Dolphin, the user will need a total of three Dolphin boards. Additional individual boards are available and may be used with either a low-power or high-power kit. The adder board part numbers are as follows:

- DOLPHIN-LP-ADDER for the low-power adder board.
- DOLPHIN-HP-ADDER for the high-power adder board.

The DBB03A is already loaded with the frequency hopping firmware. Hardware and Software documentation related to this kit are documented in Chapter 3 and Chapter 4 respectively. For more information visit the ISM band product website at <http://www.ti.com/ismrf>.

1.7 Equipment Requirement

The following equipment is not included in this kit and may be required to operate the Dolphin demo kit:

- DC power supply
- AA Batteries

Demonstrating a Wireless Link

This chapter explains how to operate Dolphin demo kit to demonstrate a RF bidirectional link.

Topic	Page
2.1 Board Description	2-2
2.2 Operational Overview	2-4

2.1 Board Description

The Dolphin demo kit consists of two circuit boards. One circuit board consists of a TRF6903 RF transceiver and a DBB03A digital basband ASIC as shown in Figure 2–1. The second circuit board is a serial interface board which consists of a RS232 serial line driver, low voltage detector, and two AA battery holder. The interface board has an option to be powered up from an external dc-power supply or two 1.5-V AA batteries. The interface board has a LED which turns off when the supply voltage falls below 2.3 V.

Each board is capable of sending and receiving half-duplex wireless data on North American/US ISM bands. The DBB03A firmware is configured to use the 902- to 928-MHz ISM frequency band. Figure 2–1 shows top-side view of the circuit board.

Figure 2–1. Top Side of the Demonstration Board

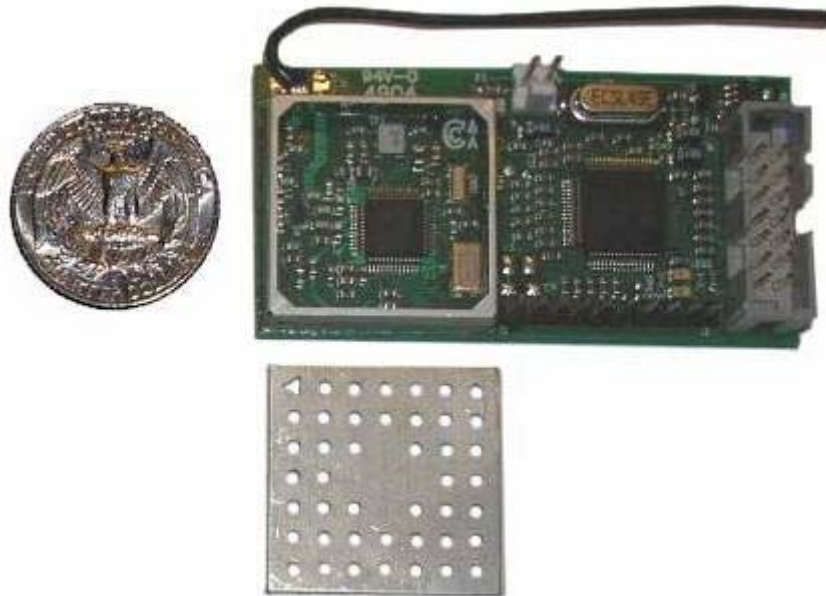
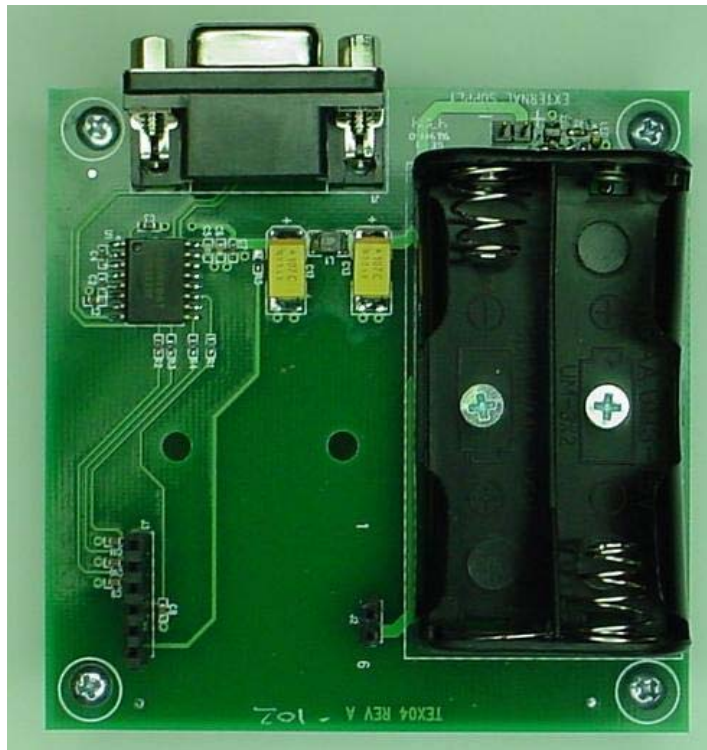

Figure 2–2. Top Side of the Serial Interface Board



Dolphin demo kit features:

- TRF6903 RF transceiver
- DBB03A digital baseband ASIC
- Simple wire antenna
- Manual reset pin for the DBB03A digital baseband ASIC
- Header for external dc-power supply
- Battery holder for two 1.5-V AA batteries (batteries not included)
- Serial interface board
- Low battery voltage indicator
- SMA connector footprint for an external antenna or test equipment (SMA connector not included)
- RS232 line driver/receiver
- Serial port connector
- External PA and SAW filter (HP version)

2.2 Operational Overview

The Dolphin kit was designed to quickly demonstrate a wireless link between two or more unique devices. The interface board provides dc-power via the onboard batteries and a serial link via RS232. This platform allows the user to easily connect to the chipset and start communication. A detailed description to set up the chipset software can be found in Chapter 4. The Dolphin demo kit can operate in two modes.

- Link Mode –Section 2.2.3
- Test Mode – Section 2.2.4

2.2.1 Preparing for Operation

Before you start operating the units as a demonstration make sure that you have done the following:

- Connect Dolphin demo board to the serial interface board by inserting the headers into the header receptacle provided on the interface board.
- The Dolphin interface board requires two 1.5-V AA size batteries. Batteries need to provide a minimum of 2.3 VDC.
- Supply power to the interface board using either a DC power supply or 2 AA batteries.
- Connect the serial port cable between the host PC (with the evaluation software installed) and the DB-9 connector on the interface board.
- Start the evaluation software and choose the appropriate serial port used for communication. (*Auto Detect* feature can be used)

2.2.2 Power Up

Insert batteries into interface board and verify LED1 blinking in two second intervals. Upon power up, both units go into receive mode to monitor for any transmit activity.

2.2.3 Wireless Demonstration – Link Mode

The link mode setup is shown in Figure 2-3. Upon power up of the devices and before communication can take place the individual devices must have the following parameters properly programmed using the Texas Instruments evaluation software.

- Destination ID (transceiver ID of the device you want to talk to)
- Network ID (identical to each other)
- System ID (identical to each other)
- Hop table (identical to each other)
- Transceiver ID (must be unique)

After the proper parameters have been programmed the user must enter data into the RF data text box and press the *Send Single Msg.* Upon successful transmission the communications log display's an acknowledgement. For more details on link mode demonstration, see Chapter 4 section 4.3.

Figure 2-3. Link Mode Demonstration

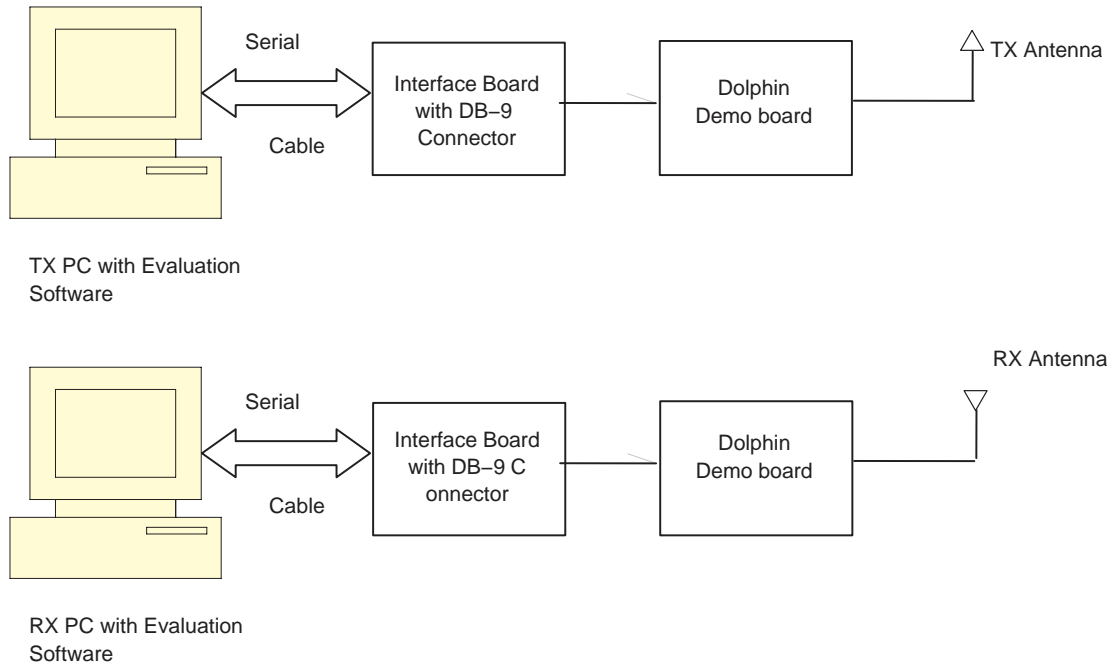

2.2.4 Test Mode

The Dolphin can be configured to be in the *test mode* to evaluate the RF performance of the TRF6903. The test mode provides an option to configure and program the TRF6903 registers. This allows the system designers additional flexibility to evaluate all the features of the TRF6903 for their application-specific needs.

The test settings page can be selected by clicking the *Test Settings* tab in the evaluation software. This is shown in NO TAG in Chapter 4.

In order to evaluate the TRF6903 in test-mode, the Dolphin evaluation board needs to be connected to the spectrum analyzer through an SMA connector. See Chapter 4 for detailed transmit and receive test plans to evaluate the TRF6903.

2.2.5 Error Conditions

If communication does not exist after numerous attempts, shutdown and restart evaluation software and cycle power on the evaluation board. Next select auto detect in the communication settings menu to establish communications.

PCB Hardware Overview

This chapter provides the default PCB hardware documentation in detail and provides alternate configurations that the user may want to implement.

Topic	Page
3.1 Hardware Overview	3-2
3.2 Low Power Version	3-5
3.3 High Power Version	3-11
3.4 Other Hardware Features	3-20

3.1 Hardware Overview

The Dolphin demonstration and development kit (Dolphin demo) provides a stand-alone demonstration of a bidirectional frequency hopping link using the DBB03A digital baseband ASIC and the TRF6903 RF transceiver.

The TRF6903 ISM-band transceiver IC operates from 315 MHz to 950 MHz. It has low power consumption and an operating voltage of 2.2 V to 3.6 V. It features an integer-N PLL synthesizer and supports FSK and OOK operation. Other features include on-chip clock recovery, brownout detector, and XTAL frequency trimming in software.

The default Dolphin system design parameters are shown in Table 3–1.

Table 3–1. Initial System Design Specifications

Operating Band	915 MHz
Crystal Frequency	19.6608 MHz
Reference Divider	48
PLL Reference Frequency	409.6 kHz
Charge Pump Current	0.5 mA
Modulation	FSK
Coding Scheme	NRZ
Peak-to-Peak Frequency Deviation	100 kHz (± 50 kHz)
Default RF Data rate	38.4 kbps

3.1.1 TRF6903 Block Diagram

Figure 3–1 shows the block diagram of the TRF6903 ISM transceiver IC.

Figure 3–1. TRF6903 Block Diagram

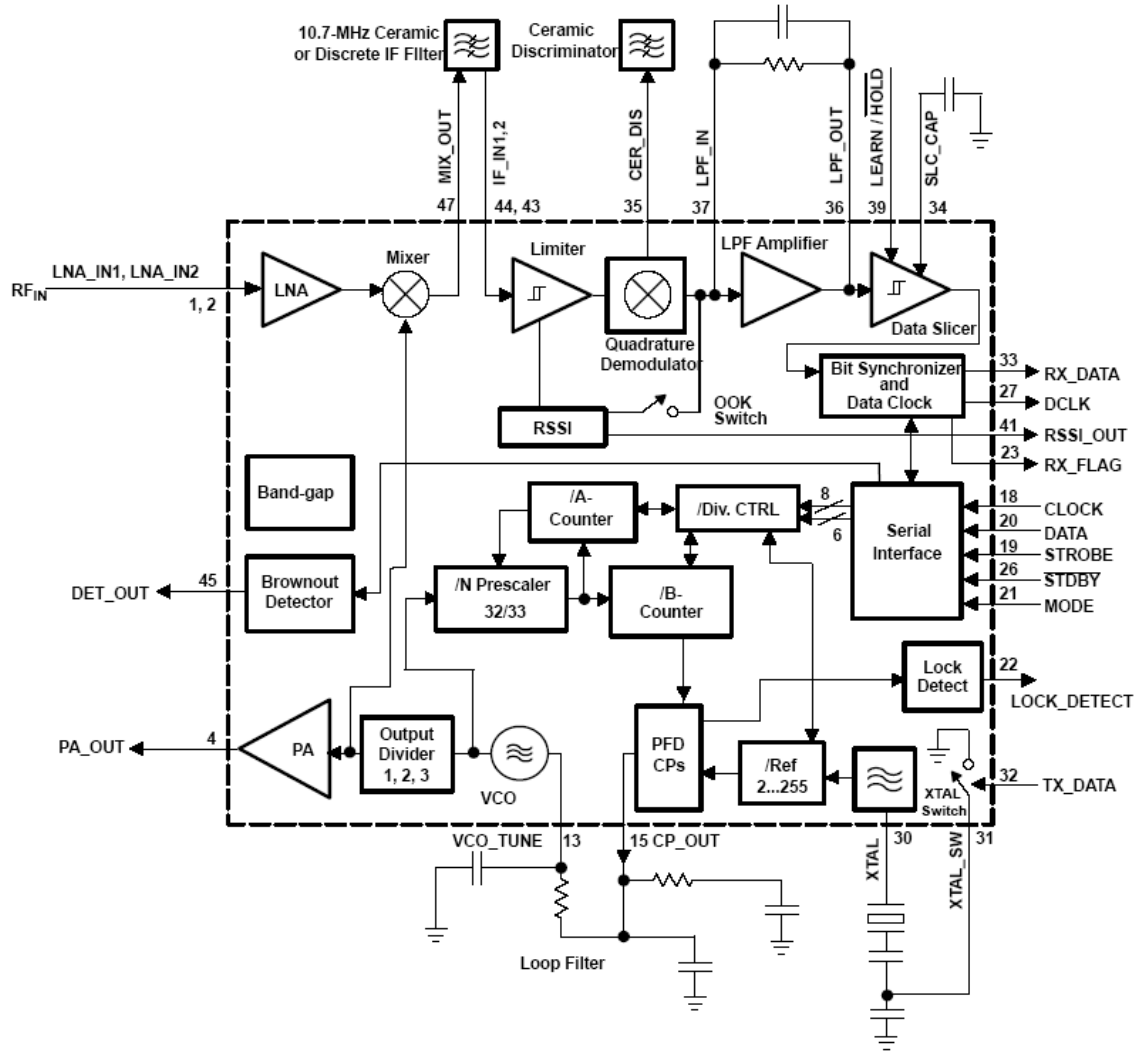

3.1.2 DBB03A Block Diagram

Figure 3–2 shows the block diagram of the DBB03A digital baseband ASIC.

Figure 3–2. DBB03A Block Diagram

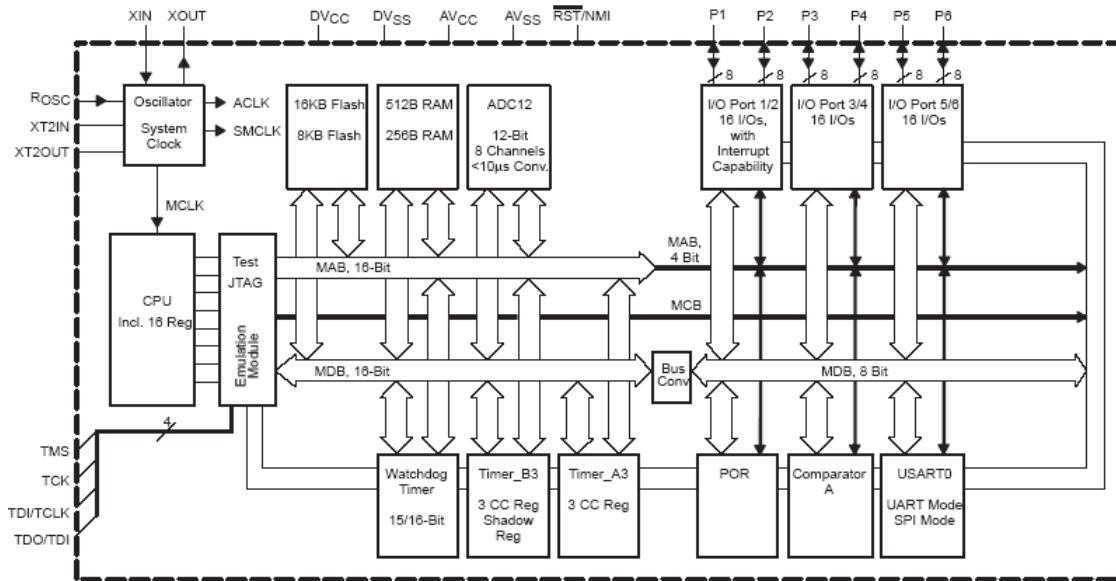

3.2 Low Power Version

The Dolphin demo kit is offered in two versions.

- Low power (LP) version (transmit power of +7 dBm max)
- High power (HP) version (transmit power of +23 dBm max) using an external PA

The low power version board is explained in the following sections. All the schematics and BOM for the Dolphin LP and HP demonstration boards can be found at <http://focus.ti.com/docs/toolsw/folders/print/dolphin-wuart-ref.html>.

3.2.1 Overview

The low power version of the Dolphin demo kit is shown in Figure 3–3.

Figure 3–3. Dolphin Low Power Board

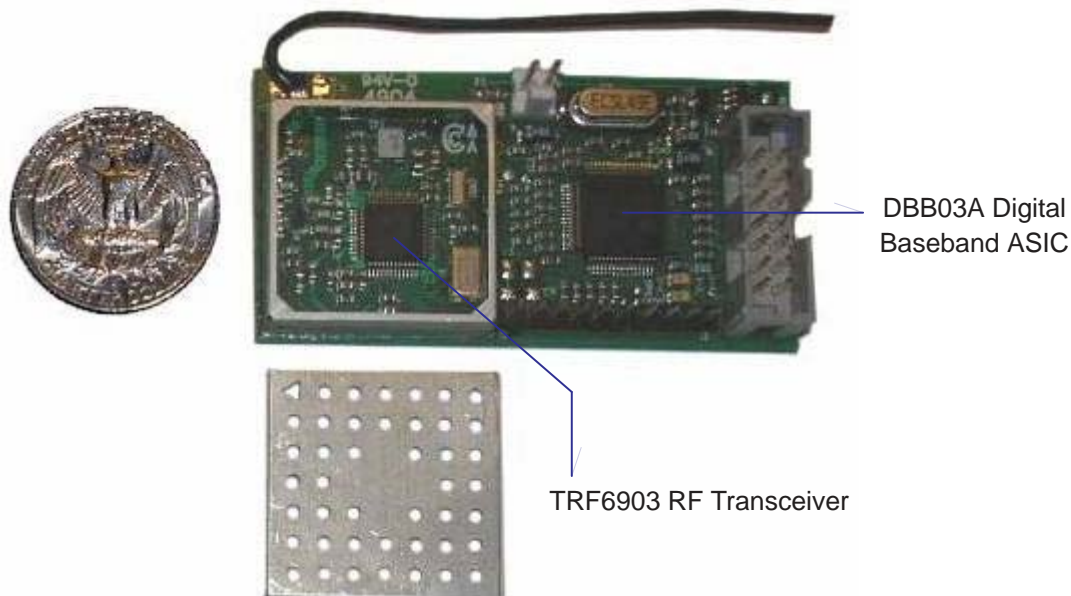

The performance of the Dolphin LP board is summarized in Table 3–2. For detailed LP board performance results, see Appendix A.

Table 3–2. Low Power (LP) Board Performance Summary

Mode	Parameter	Value	Units
Transmit	Transmit current	35.3	mA
	Output power	7	dBm
	20-dB modulated bandwidth	210	kHz
	Peak-peak deviation	100	kHz
Receive	Receive current	18.8	mA
	Sensitivity	–101	dBm
	LO power level	–97.7	dBm
Standby	Standby current	0.1	μA

3.2.2 Schematics

The schematic of the LP board is shown in Figure 3-4.

Figure 3-4. Low Power Board Schematic

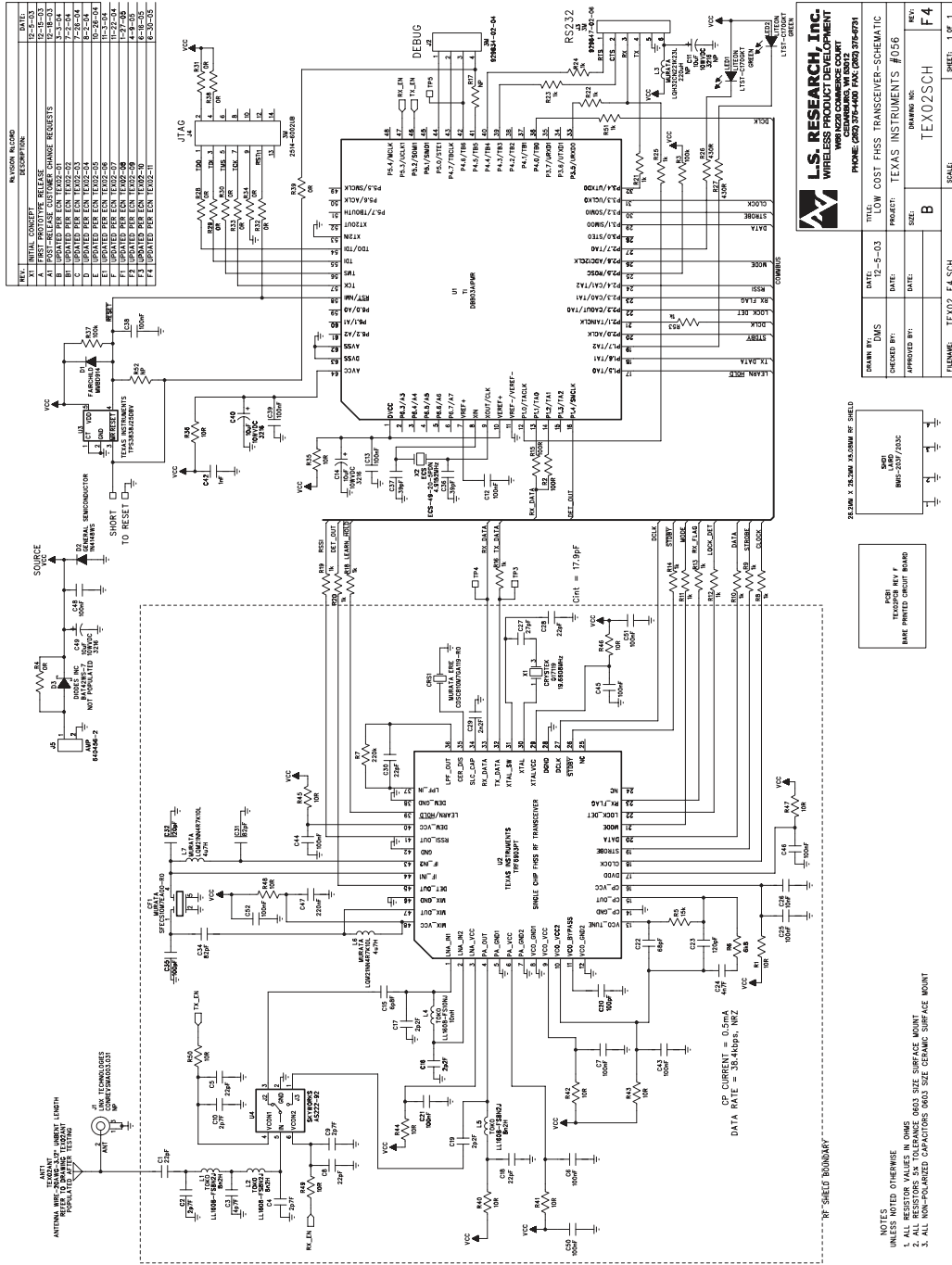

3.2.3 Top and Bottom Side of the LP Board

Figure 3–5 and Figure 3–6 show the top-side and bottom-side circuit board for the LP version Dolphin demo board.

Figure 3–5. Top Side (LP Version)

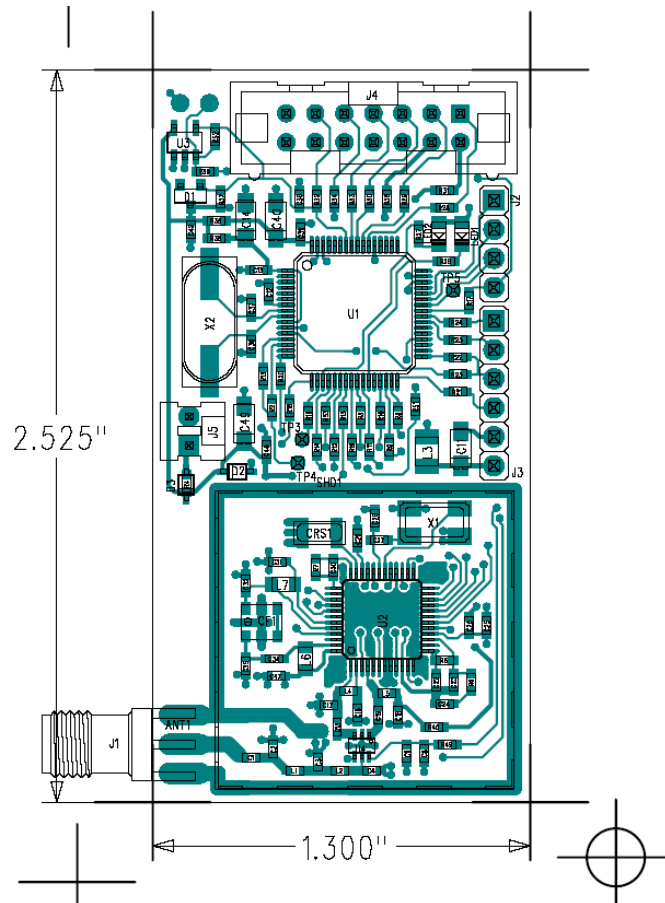
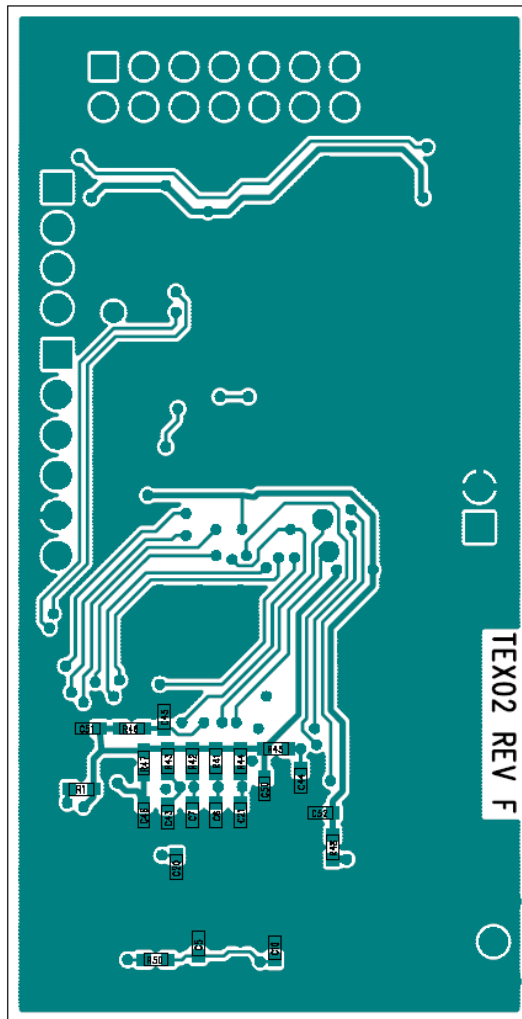

Figure 3–6. Bottom Side (LP Version)



3.2.4 BOM for the LP Version

Item	Qty	Reference	Pop Option	Value	Tol.	Voltage / Power	Manufacturer	Part Number	Description	Substitute	PCB Decal
1	1	ANT1	Populated after testing	See drawing TEX02ANT			Custom	TEX02ANT	Antenna wire 20AWG-3.1 2" Unbent length		SIP-1 P
2	3	C16, C17, C19		2.2 pF	0.25 pF	50 V NPO	Any		0603 Size SMT ceramic capacitor	Any	0603
3	4	C2, C4, C9, C10		2.7 pF	0.25 pF	50 V NPO	Any		0603 Size SMT ceramic capacitor	Any	0603
4	1	C3		4.7 pF	0.25 pF	50 V NPO	Any		0603 Size SMT ceramic capacitor	Any	0603
5	1	C15		6.8 pF	0.5 pF	50 V NPO	Any		0603 Size SMT ceramic capacitor	Any	0603
6	6	C1, C5, C8, C18, C28, C30		22 pF	5%	50 V NPO	Any		0603 Size SMT ceramic capacitor	Any	0603
7	1	C27		27 pF	5%	50 V NPO	Any		0603 Size SMT ceramic capacitor	Any	0603
8	2	C36, C37		39 pF	5%	50 V NPO	Any		0603 Size SMT ceramic capacitor	Any	0603
9	1	C22		68 pF	5%	50 V NPO	Any		0603 Size SMT ceramic capacitor	Any	0603
10	2	C31, C34		82 pF	5%	50 V NPO	Any		0603 Size SMT ceramic capacitor	Any	0603
11	2	C20, C35		100 pF	5%	50 V NPO	Any		0603 Size SMT ceramic capacitor	Any	0603
12	2	C23, C32		120 pF	5%	50 V NPO	Any		0603 Size SMT ceramic capacitor	Any	0603
13	1	C42		1 nF	10%	50 V X7R	Any		0603 Size SMT ceramic capacitor	Any	0603
14	1	C29		2.2 nF	10%	50 V X7R	Any		0603 Size SMT ceramic capacitor	Any	0603
15	1	C24		4.7 nF	10%	50 V X7R	Any		0603 Size SMT ceramic capacitor	Any	0603
16	1	C26		10 nF	10%	50 V X7R	Any		0603 Size SMT ceramic capacitor	Any	0603

Notes: 1. NP indicates component position currently Not populated.

SLLU090.Sect.3.2.4Page 3-9 of NO TAG

2. DUO indicates component position populated in development units only.

3. ANT1 to be shipped separately (unsoldered) with units until manufacturing establishes testing procedures for units with antenna mounted.

Item	Qty	Reference	Pop Option	Value	Tol.	Voltage / Power	Manufacturer	Part Number	Description	Substitute	PCB Decal
17	16	C6, C7, C12, C13, C21, C25, C38, C39, C43, C44, C45, C46, C48, C50, C51, C52		100 nF	10%	16 V X7R	Any		0603 Size SMT ceramic capacitor	Any	0603
18	1	C47		220 nF	10%	10 V X5R	Any		0603 Size SMT ceramic capacitor	Any	0603
19	1	C11	NP	10 uF	10%	10 WVDC			Surface mount tant. capacitor 'A' case size		3216
20	3	C14, C40, C49		10 uF	10%	10 WVDC			Surface mount tant. capacitor 'A' case size		3216
21	1	CF1		F _c = 10.7 MHz, BW = 330 kHz			Murata	SFECS10M7 EA00-R0	Piezoelectric ceramic filter		Murat a-SF ECS
22	1	CRS1		10.7 MHz			Murata Erie	CDSCB10M 7GA119-R0	2-pin ceramic resonator		Murat a-CD SCB
23	1	D1	DUO				Fairchild	MMBD914	High condition ultra fast diode		SOT2 3
24	1	D2					General Semiconductor	1N4148WS	Small signal switching diode		SOD-323
25	1	D3	NP	Not populated			Diodes INC	BAT42WS-7	SMT Schottky diode		SOD-323
26	1	J1	NP				Linx technologies	CONREVSM A003.031	0.031" narrow edge mount SMA connector		SMA-Narrow
27	1	J2	DUO				3M	929834-02-04	4-pin 0.1" header	Make from 3M 929834-02-36	SIP-4 P
28	1	J3	DUO				3M	929647-02-06	6-pin 0.1" strip header	Make from 3M 929647-02-36	SIP-6 P
29	1	J4	DUO				3M	2514-6002UB	7X2 low profile shrouded male header		Header 7X2 -POL
30	1	J5					AMP	640456-2	2-pin 0.1" polarized friction lock header		AMP6 4045 6-2

- Notes:**
1. NP indicates component position currently Not populated.
 2. DUO indicates component position populated in development units only.
 3. ANT1 to be shipped separately (unsoldered) with units until manufacturing establishes testing procedures for units with antenna mounted.

Item	Qty	Reference	Pop Option	Value	Tol.	Voltage / Power	Manufacturer	Part Number	Description	Substitute	PCB Decal
31	1	L4		10 nH	5%		TOKO	LL1608-FS1 0NJ	0603 size chip inductor	TOKO LL1608FH	0603
32	3	L1, L2, L5		8.2 nH	5%		TOKO	LL1608-FS8 N2J	0603 size chip inductor	TOKO LL1608FH	0603
33	1	L3	NP	220 μ H	10%		Murata	LQH32CN22 1K23L	SMT RF CHOKE	Murata LQH32MN 221K23L	1210
34	2	L6, L7		4.7 μ H	10%		Murata	LQM21NN4 R7K10L	SMT multilayer inductor		0805
35	2	LED1, LED2	DUO	Green		2.1 V 10 mA	LITEON	LTST-C170 GKT	0805 SIZE SMT LED		0805 -LED
36	1	PCB1						TEX02PCB REV F	Bare printed circuit board		
37	1	R17	NP	NP		1/16 W	Any		0603 surface mount resistor	Any	0603
38	2	R4, R39		0 R		1/16 W	Any		0603 surface mount resistor	Any	0603
39	8	R28-R34, R38	DUO	0 R		1/16 W	Any		0603 surface mount resistor	Any	0603
40	1	R52	NP	0 R when U3 is NP		1/16 W	Any		0603 surface mount resistor	Any	0603
41	14	R1, R35, R36, R40-R50		10 R	5%	1/16 W	Any		0603 surface mount resistor	Any	0603
42	2	R2, R15		100 R	5%	1/16 W	Any		0603 surface mount resistor	Any	0603
43	2	R26, R27	DUO	430 R	5%	1/16 W	Any		0603 surface mount resistor	Any	0603
44	18	R8-R25, R51, R53		1 k	5%	1/16 W	Any		0603 surface mount resistor	Any	0603
45	1	R6		6.8 k	5%	1/16 W	Any		0603 surface mount resistor	Any	0603
46	1	R5		15 k	5%	1/16 W	Any		0603 surface mount resistor	Any	0603
47	1	R3		100 k	5%	1/16 W	Any		0603 surface mount resistor	Any	0603
48	1	R37	DUO	100 k	5%	1/16 W	Any		0603 surface mount resistor	Any	0603

Notes: 1. NP indicates component position currently Not populated.

2. DUO indicates component position populated in development units only.

3. ANT1 to be shipped separately (unsoldered) with units until manufacturing establishes testing procedures for units with antenna mounted.

Item	Qty	Reference	Pop Option	Value	Tol.	Voltage / Power	Manufacturer	Part Number	Description	Substitute	PCB Decal
49	1	R7		220 k	5%	1/16 W	Any		0603 surface mount resistor	Any	0603
50	1	SHD1					BMI	BMIS-103	26,2 mm x 26,2 mm x 5,08 mm RF shield	BMIS-203 F/203C	BMI S-103
51	1	U1					Texas Instruments	DBB03AIPMR	Baseband ASIC		QFP 64
52	1	U2					Texas Instruments	TRF6903	Single chip FHSS RF transceiver		QFP 48-3
53	1	U3	DUO				Texas Instruments	TPS3838J25 DBV	Nanopower supervisory circuit		SOT 23-5
54	1	U4					Skyworks	AS222-92	PHEMT IC SPDT GaAs switch	AS179-92	SOT 363
55	1	X1		19.6608 MHz	±20 ppm	CL 12 pF	Crystek	17119	SMT quartz crystal		ECS -EC X-64
56	1	X2		4.9152 MHz	±50 ppm	Op Temp -40°C to 85°C	ECS	ECS-49-20-5PDN	CSM-7 style SMT crystal	CRYSTEK 017418	ECS -CS M-7

SLLU090, Sect.3.2.4 Page 3-12 of NO TAG

Notes: 1. NP indicates component position currently Not populated.

2. DUO indicates component position populated in development units only.

3. ANT1 to be shipped separately (unsoldered) with units until manufacturing establishes testing procedures for units with antenna mounted.

3.3 High Power Version

3.3.1 Overview

The Dolphin high power board is designed to obtain output powers of up to +23 dBm using an external PA. The maximum output power of +23 dBm is obtained with $V_{CC} = 3.6$ V. If the demo board is powered using two AA batteries ($V_{CC} = 3$ V), the output power is +20 dBm. The external PA used is RFMD RF2172. The data sheet for this external PA can be downloaded from the <http://www.rfmd.com/DataBooks/db97/2172.pdf> website.

The high power dolphin board is shown in Figure 3-7.

Figure 3–7. High Power (HP) Board

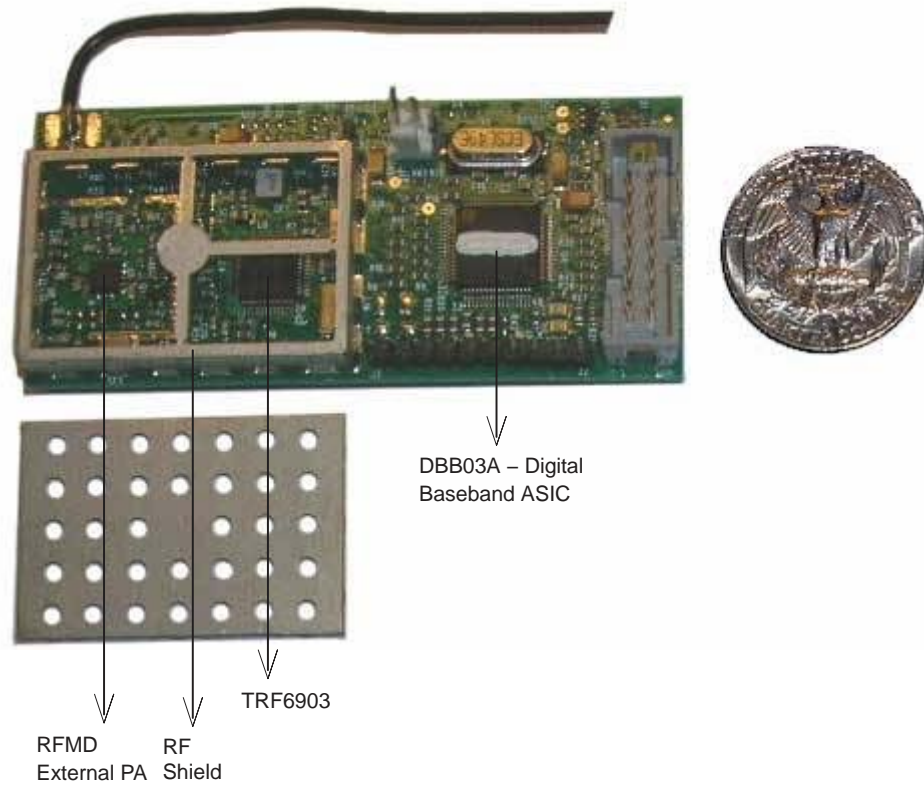

The performance of the HP board is displayed in Table 3–3. For detailed HP board performance results, see Appendix A.

Table 3–3. HP Board Performance

Mode	Parameter	V _{CC} = 3 V	V _{CC} = 3.6 V	Units
Transmit	Transmit current	147.9	190.3	mA
	Output power (typical)	20	23	dBm
	20-dB modulated bandwidth	206	196	kHz
	Peak-peak deviation	100	100	kHz
Receive	Receive current	23.1	21.5	mA
	Sensitivity	–100	–100	dBm
	LO power level	–97.7	–97.7	dBm
Standby	Standby current	0.1	0.1	μA

3.3.3 Different Layers of the HP Board

Top, bottom, and middle layers of the four layer HP board are shown in Figure 3-9 and Figure 3-10.

Figure 3-9. Top Layer and Layer 2 (HP Version)

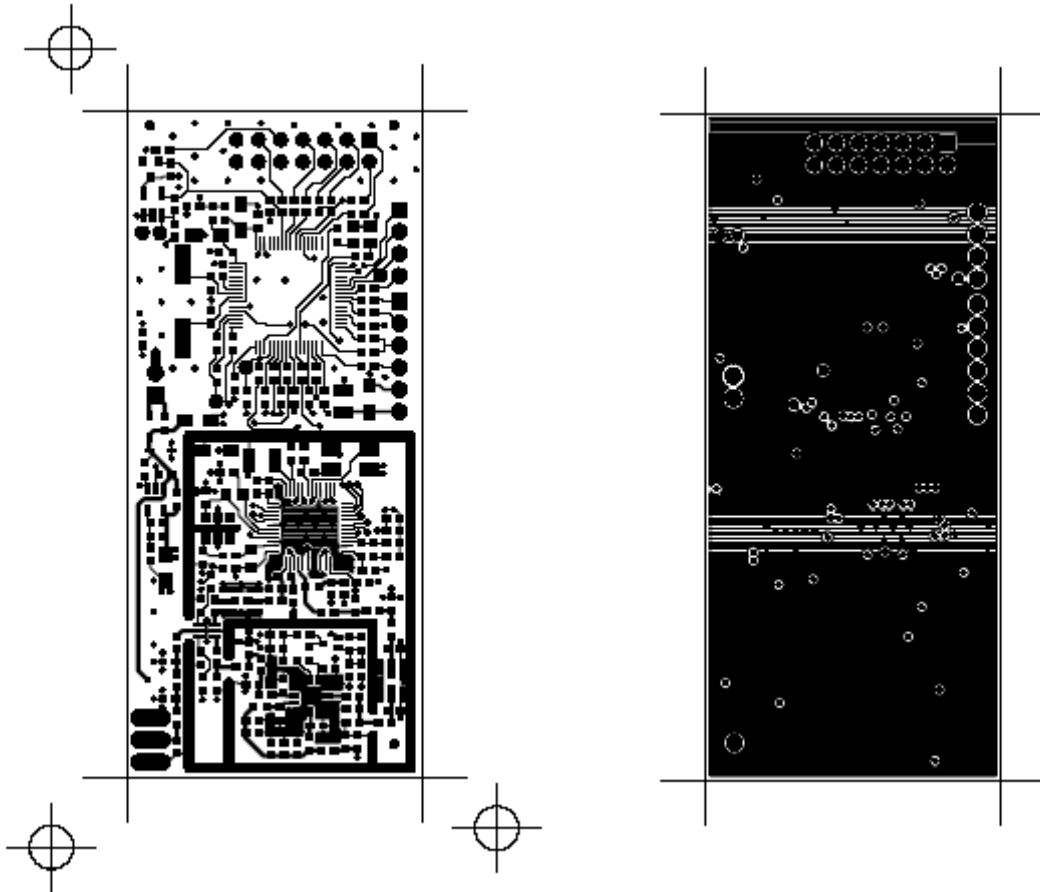
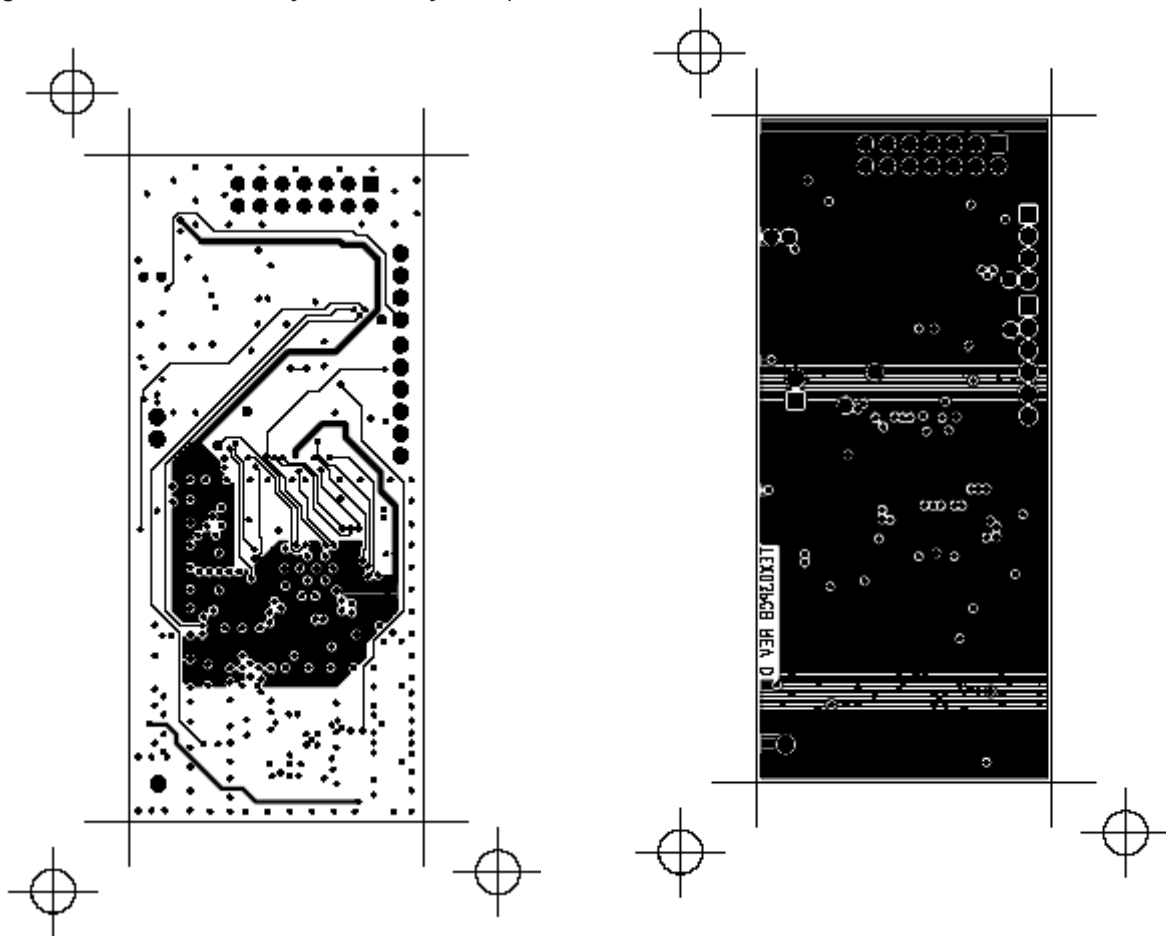

Figure 3-10. Bottom Layer and Layer 3 (Hi



3.3.4 BOM for the HP Version

Item	Qty	Reference	Population Option	Value	Tol.	Voltage / Power	Manufacturer	Part No.	Description	Substitute	PCB Decal
1	1	ANT1	Populated after testing				TBD	TEX03ANT	3.06" long unbent 20 AWG antenna wire, see fabrication drawing TEX03ANT rev C for details		SIP-1P
2	1	C71, C59		0.5 pF	0.1 pF	250 V NPO	ATC	ATC600S0R 5BW250	0603 Size SMT ceramic capacitor		0603
3	1	C2		1.2 pF	0.1 pF	250 V NPO	ATC	ATC600S1R 8BW250	0603 Size SMT ceramic capacitor		0603
4	1	C62		2.2 pF	0.1 pF	250 V NPO	ATC	ATC600S2R 2BW250	0603 Size SMT ceramic capacitor		0603
5	2	C60, C76		3.3 pF	0.1 pF	250 V NPO	ATC	ATC600S3R 3BW250	0603 Size SMT ceramic capacitor		0603
6	3	C1, C3, C70		3.9 pF	0.25 pF	250 V NPO	ATC	ATC600S3R 9CW250	0603 Size SMT ceramic capacitor		0603
7	1	C61		5.6 pF	0.25 pF	250 V NPO	ATC	ATC600S5R 6CW250	0603 Size SMT ceramic capacitor		0603
8	1	C77		10 pF	5%	250 V NPO	ATC	ATC600S10 0JW250	0603 Size SMT ceramic capacitor		0603
9	1	C72		20 pF	5%	250 V NPO	ATC	ATC600S20 0JW250	0603 Size SMT ceramic capacitor		0603
10	1	C73		100 pF	5%	250 V NPO	ATC	ATC600S10 1JW250	0603 Size SMT ceramic capacitor		0603
11	6	C55, C56, C57, C67, C78	NP			50 V NPO	Any		0603 Size SMT ceramic capacitor	Any	0603
12	3	C16, C17, C19		2.2 pF	0.25p F	50 V NPO	Any		0603 Size SMT ceramic capacitor	Any	0603
13	11	C5, C8, C9, C10 C18, C28, C30, C53, C54, C64, C65		22 pF	5%	50 V NPO	Any		0603 Size SMT ceramic capacitor	Any	0603
14	1	C27		27 pF	5%	50 V NPO	Any		0603 Size SMT ceramic capacitor	Any	0603
15	2	C36, C37		39 pF	5%	50 V NPO	Any		0603 Size SMT ceramic capacitor	Any	0603
16	1	C22		68 pF	5%	50 V NPO	Any		0603 Size SMT ceramic capacitor	Any	0603
17	2	C31, C34		82 pF	5%	50 V NPO	Any		0603 Size SMT ceramic capacitor	Any	0603
18	2	C20, C35		100 pF	5%	50 V NPO	Any		0603 Size SMT ceramic capacitor	Any	0603
19	2	C23, C32		120 pF	5%	50 V NPO	Any		0603 Size SMT ceramic capacitor	Any	0603
20	2	C42, C68		1 nF	5%	50 V NPO	Any		0603 Size SMT ceramic capacitor	Any	0603
21	1	C29		2.2 nF	10%	50 V X7R	Any		0603 Size SMT ceramic capacitor	Any	0603
22	1	C24		4.7 nF	10%	50 V X7R	Any		0603 Size SMT ceramic capacitor	Any	0603
23	5	C58, C63, C66, C74, C75		22 nF	10%	50 V X7R	Any		0603 Size SMT ceramic capacitor	Any	0603
24	7	C7, C25, C38, C39, C41, C43, C48		100 nF	10%	16 V X7R	Any		0603 Size SMT ceramic capacitor	Any	0603

Notes: 1. NP indicates component position currently Not populated.

2. DUO indicates component position populated in development units only.

3. ANT1 to be shipped separately (unsoldered) with units until manufacturing establishes testing procedures for units with antenna mounted.

High Power Version

Item	Qty	Reference	Population Option	Value	Tol.	Voltage / Power	Manufacturer	Part No.	Description	Substitute	PCB Decal
25	1	C47		220 nF	10%	10 V X7R	Any		0603 Size SMT ceramic capacitor	Any	0603
26	5	C4, C6, C40, C49, C79		10 uF	10%	10 WVDC			Surface mount tant. capacitor 'A' case size	Any	3216
27	1	C80	NP	10 uF	10%	10 WVDC			Surface mount tant. capacitor 'A' case size	Any	3216
28	1	CF1		Fc = 10.7 MHz, BW = 330 kHz			Murata	SFECS10M7EA00-R0	Piezoelectric ceramic filter	Any	Murata-SF ECS
29	1	CRS1		10.7 MHz			Murata	CDSCB10M7GA119-R0	2-pin ceramic resonator		Murata-C DSCB
30	1	D1	DUO				Fairchild	MMBD914	High cond. ultra fast diode		SOT23
31	1	D2					General Semiconductor	1N4148WS	Small signal switching diode		SOD-323
32	1	D	NP				diodeS INC	BAT42WS-7	SMT Schottky diode		SOD-323
33	1	J1	NP				HUS-TSAN Group	SMA-10V2 9-TGN-RP	Reverse polarity edge mount SMA connector	LINX CONREV SMA003.062	SMA-NARROW
34	1	J2	DUO				3M	929834-02-04	4-pin 0.1" header	Make from 3M 929834-02-36	SIP-4P
35	1	J3	DUO				3M	929647-02-06	6-pin 0.1" strip header	Make from 3M 929647-02-36	SIP-6P
36	1	J4	DUO				3M	2514-6002 UB	7X2 low profile shrouded male header		Header7X2-POL
37	1	J5					AMP	640456-2	2-pin 0.1" polarized friction lock header		AMP640456-2
38	1	L16	NP	220 uH	10%		Murata	LQH32CN2 21K23L	Chip inductor	LQH32M N221K23 L	1210
39	2	L6, L7		4.7 uH	10%		Murata	LQM21NN4 R7K10L	Chip inductor		1008
40	1	L4		10 nH	5%		TOKO	LL1608-FS 10NJ	0603 Size Chip inductor	TOKO LL1608F SL	0603
41	1	L14		1.2 nH	0.3 nH		TOKO	LL1608-FS 1N2S	0603 Size Chip inductor	TOKO LL1608F SL	0603
42	1	L15		1.8 nH	0.3 nH		TOKO	LL1608-FS 1N8S	0603 Size Chip inductor	TOKO LL1608F SL	0603
43	2	L13		3.9 nH	0.3 nH		TOKO	LL1608-FS 3N9S	0603 Size Chip inductor	TOKO LL1608F SL	0603
44	1	L11		4.7 nH	0.3 nH		TOKO	LL1608-FS 4N7S	0603 Size Chip inductor	TOKO LL1608F SL	0603
45	1	L12		6.8 nH	5%		TOKO	LL1608-FS 6N8J	0603 Size Chip inductor	TOKO LL1608F SL	0603

Notes: 1. NP indicates component position currently Not populated.

2. DUO indicates component position populated in development units only.

3. ANT1 to be shipped separately (unsoldered) with units until manufacturing establishes testing procedures for units with antenna mounted.

Item	Qty	Reference	Population Option	Value	Tol.	Voltage / Power	Manufacturer	Part No.	Description	Substitute	PCB Decal
46	3	L1, L2, L5		8.2 nH	5%		TOKO	LL1608-FS 8N2J	0603 Size Chip inductor	TOKO LL1608F SL	0603
47	2	L9, L10	NP	5.6 nH	5%		TOKO	LL1608-FS 5N6J	0603 Size Chip inductor	TOKO LL1608F SL	0603
48	2	LED1, LED2	DUO	Green		2.1 V 10 mA	LITEON	LTST-C170 GKT	0805 Size SMT LED		0805-LED
49	1	Q1					R ohm	UMT3906	General purpose PNP silicon transistor		SOT323
50	5	R1, R2, R38, R41, R52		0 Ω		1/16 W	Any		0603 surface mount resistor	Any	0603
51	8	R28-R34, R43	DUO	0 Ω		1/16 W	Any		0603 surface mount resistor	Any	0603
52	5	R35, R36, R40, R60, R61		10 R	5%	1/16 W	Any		0603 surface mount resistor	Any	0603
53	1	R51		18 R	5%	1/16 W	Any		0603 surface mount resistor	Any	0603
54	3	R55, R63, R70		100 R	5%	1/16 W	Any		0603 surface mount resistor	Any	0603
55	2	R49, R50		300 R	5%	1/16 W	Any		0603 surface mount resistor	Any	0603
56	2	R26, R27	DUO	430 R	5%	1/16 W	Any		0603 surface mount resistor	Any	0603
57	1	R53		510 R	5%	1/16 W	Any		0603 surface mount resistor	Any	0603
58	18	R8-R25, R64		1 k	5%	1/16 W	Any		0603 surface mount resistor	Any	0603
59	2	R54 R56		3.3 k	5%	1/16 W	Any		0603 surface mount resistor	Any	0603
60	2	R6, R57		6.8 k	5%	1/16 W	Any		0603 surface mount resistor	Any	0603
61	1	R5		15 k	5%	1/16 W	Any		0603 surface mount resistor	Any	0603
62	1	R58		22 k	5%	1/16 W	Any		0603 surface mount resistor	Any	0603
63	1	R59		33 k	5%	1/16 W	Any		0603 surface mount resistor	Any	0603
64	1	R71		100 k	5%	1/16 W	Any		0603 surface mount resistor	Any	0603
65	1	R37	DUO	100 k	5%	1/16 W	Any		0603 surface mount resistor	Any	0603
66	1	R7		220 k	5%	1/16 W	Any		0603 surface mount resistor	Any	0603
67	5	R3, R4, R42, R68, R69	NP			1/16 W	Any		0603 surface mount resistor	Any	0603
68	1	R39	NP	0 Ω when U3 is NP							
69	1	SF1	NP				EPCOS	B39921-B4 637-Z610	Low loss filter		Murata-SA FC
70	1	SF2					EPCOS	B39921-B4 637-Z610	Low loss filter		Murata-SA FC
71	1	SHD1					BMI	BMIS-105	25 mm x 37,7 mm x 5,08 mm RF shield	BMIS-20 5F/205C	BMIS-105
72	1	SHD3					BMI	BMIS-102	16,5 mm x 16,5 mm x 3,6 mm RF shield	BMIS-20 2F/202C	BMIS-102

Notes: 1. NP indicates component position currently Not populated.

2. DUO indicates component position populated in development units only.

3. ANT1 to be shipped separately (unsoldered) with units until manufacturing establishes testing procedures for units with antenna mounted.

Other Hardware Features

Item	Qty	Reference	Population Option	Value	Tol.	Voltage / Power	Manufacturer	Part No.	Description	Substitute	PCB Decal
73	1	U1					RF Microdevices	RF2172	ISM band 250-mW Amp		RFMD-LC C16_SLUG
74	1	U2					Texas Instruments	TRF6903	Single chip FHSS RF transceiver		QFP48-3
75	1	U3	DUO	2.5 V			Texas Instruments	TPS3838J2 5DBV	Nanopower supervisory circuit		SOT23-5
76	1	U4					Texas Instruments	DBB03AIP MR	Baseband ASIC		QFP64
77	1	U5					Skyworks	AS179-92	PHEMT IC SPDT GaAs switch		SOT363
78	1	U6	NP			100 mA	Texas Instruments / Burr Brown	REG101NA -A	Low dropout linear regulator		SOT23-5
79	1	X1		19.6608 MHz	±20 ppm	CL 12 pF	Crystek	017119	SMT quartz crystal		ECS-ECX -64
80	1	X2		4.9152 MHz	±50 ppm	Op Temp -40°C to 85°C	ECS	ECS-49-20 -5PDN	CSM-7 style SMT crystal	Crystek 017418	ECS-CSM -7
81	1	PCB1					TBD	TEX03PCB REV D	Bare printed circuit board		

- Notes:**
1. NP indicates component position currently Not populated.
 2. DUO indicates component position populated in development units only.
 3. ANT1 to be shipped separately (unsoldered) with units until manufacturing establishes testing procedures for units with antenna mounted.

3.4 Other Hardware Features

The external hardware features used for the Dolphin demo kit are detailed in this section. See the TRF6903 design guide (SWRU009) for more in depth discussion of external components used in the transmit and receive path.

3.4.1 Dolphin Interface Board

The Dolphin demo kit consists of an interface board that consists of circuitry for serial interface between the host PC (with the evaluation software) and the hardware UART of the DBB03A device. The interface board also supplies power to the RF module and features a low voltage detector circuit for battery powered operation. The board features are summarized below. The schematic is shown in Figure 3-11 and the top side of the PCB is shown in Figure 3-12.

- On-board DB-9 connector
- Serial Line Driver
- Two AA Battery Holder
- Jumper for External DC Power Supply
- Low Voltage Detector (<2.3 V)

Figure 3–11. Dolphin Interface Board Schematic

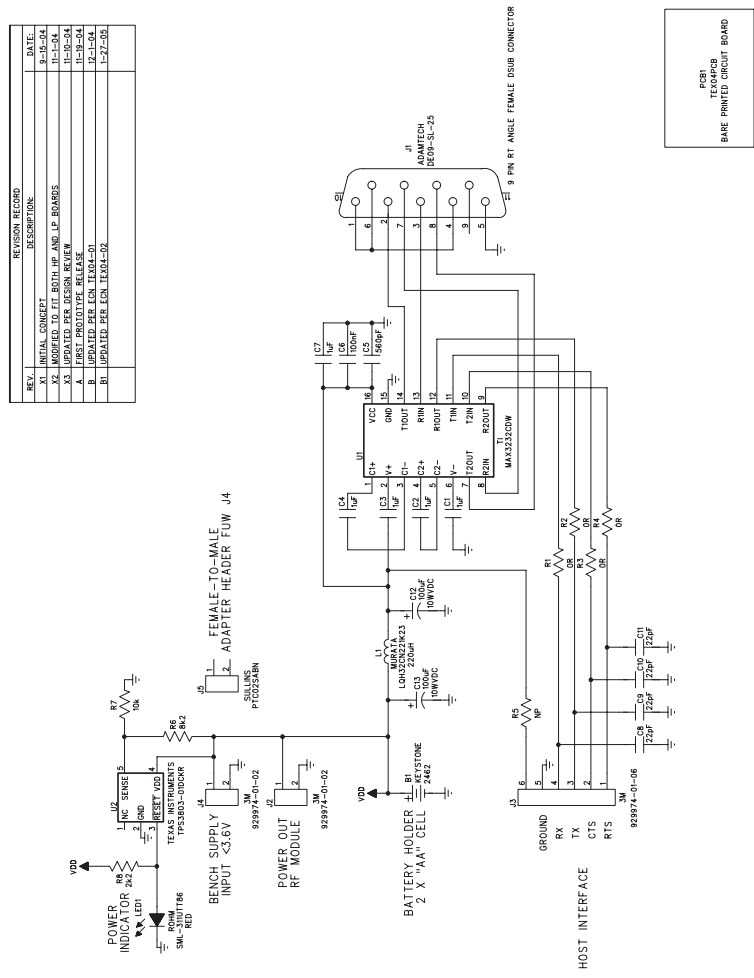

PCB
 01-000003
 BARE PRINTED CIRCUIT BOARD

Figure 3–12. Top-Side Assembly of the Interface Board

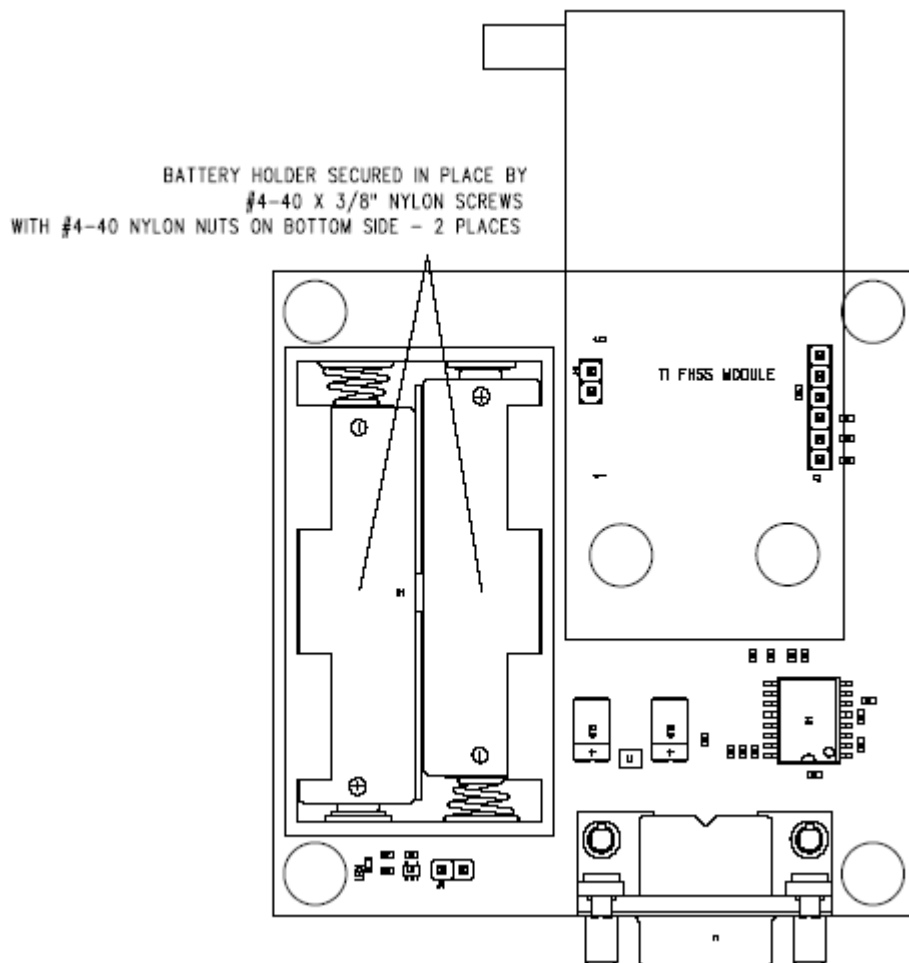

3.4.2 Antenna and RF Shield

Both the LP and HP boards use a low cost solid 20 gauge wire antenna. The length has been trimmed to provide an input return loss of at least 10 dB across the 902-MHz to 928-MHz frequency band. With the wire antenna removed, room has been provided on the boards to use a commercially available antenna. In this case, use a reverse polarity SMA connector to remain FCC compliant. See the TRF6903 design guide (SWRU009) Section 8.6 for a complete list of various antenna manufacturers/suppliers.

A standard size RF shield has to be used to ensure that the radiated emissions are FCC compliant. See Section 3.3.4 for information on the manufacturer and part number for the RF shield used with the Dolphin demo kit.

3.4.3 Discrete LC Filter for Harmonic Suppression

The second and third harmonics generated by the TRF6903 power amplifier are typically -25 dBc and -30 dBc respectively, see the TRF6903 data sheet (SWRS022). If higher suppression is needed, the second and third harmonics

can be attenuated (to meet governmental regulations) through the use of a discrete LC filter or a SAW filter. However, for most applications an external SAW filter or discrete LC filter may not be necessary.

A discrete LC filter, if needed, is the preferred method to gain additional suppression. The discrete LC filter for the low power Dolphin demo kit is shown in Figure 3–13. The filter must have low insertion loss in the RF pass band to avoid excessive loss of signal.

This two stage filter attenuates the harmonics to be at least 6 dB below the estimated conducted FCC limit. The FCC limits are in terms of radiated emissions (electric field), measured at a three meter distance. It can be shown that the relationship between the conducted power and the electric field can be estimated using: $P = E - 95.2$, where P is in dBm and E is in dB μ V/m. An antenna gain of 0 dBi is assumed.

Figure 3–13. Discrete LC Filter

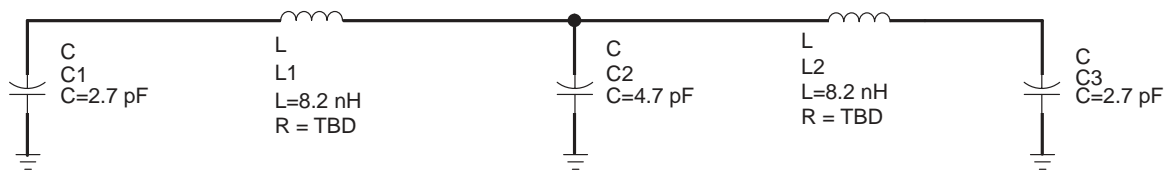

3.4.4 IF Filter

The recommended IF filter is a Murata SF ECS10M7EA00–R0, which is a 10.7-MHz ceramic filter with a bandwidth of 330 kHz. The frequency characteristics of recommended Murata SF ECS10M7EA00 330 kHz filter is shown in the Figure 3–14. The center frequency of this filter varies by ± 30 kHz and the 3-dB bandwidth varies by as much as ± 50 kHz. This is summarized in Table 3–4.

Table 3–4. Murata IF Filter SF ECS10M7EA00–R0

Center Frequency (MHz)	3-dB Bandwidth (kHz)	Attenuation (kHz)	Insertion Loss (dB)	Spurious Attenuation (dB)	Input/Output Impedance (Ω)
10.7 \pm 30 kHz	330 \pm 50 kHz	700 max	3 \pm 2	30 min	330

Figure 3–14. Recommended IF Filter Response

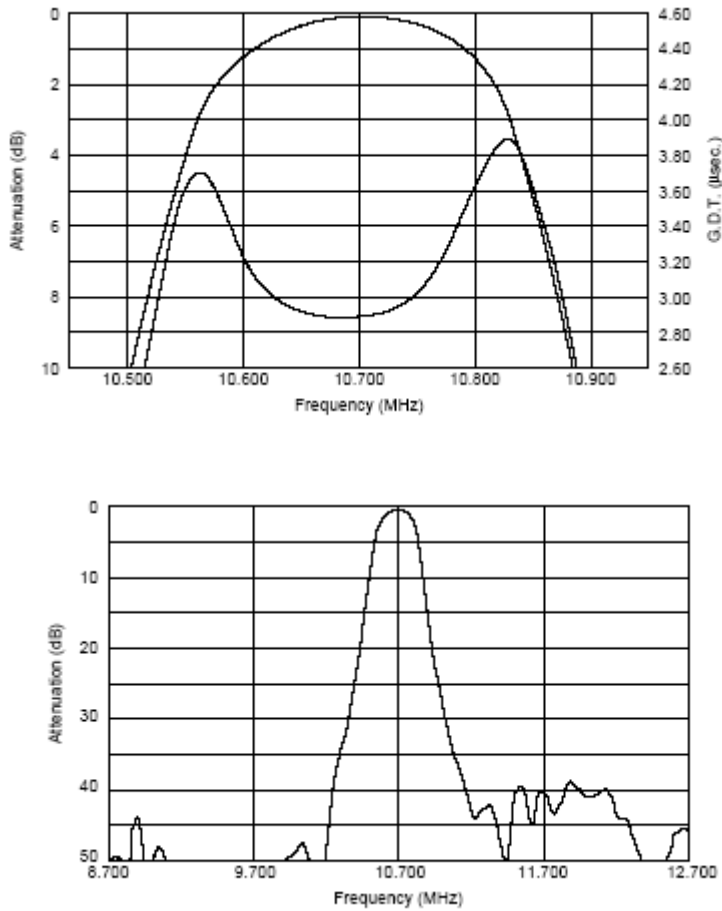

3.4.5 Ceramic Discriminator

FSK demodulation (frequency to amplitude conversion) is accomplished through an external ceramic discriminator. The recommended discriminator is the MURATA CDSCB10M7GA119–R0. The frequency characteristics are shown in Figure 3–15 and the specifications are tabulated in Table 3–5.

Table 3–5. Murata Ceramic Discriminator CDSCB10M7GA119–R0

Center Frequency (MHz)	Recovered Audio 3-dB Bandwidth (kHz)	Distortion (%)	Detection Method
10.7 ±30 kHz	500 min	1 max	Quadrature

Figure 3–15. Murata Ceramic Discriminator – Frequency Characteristics

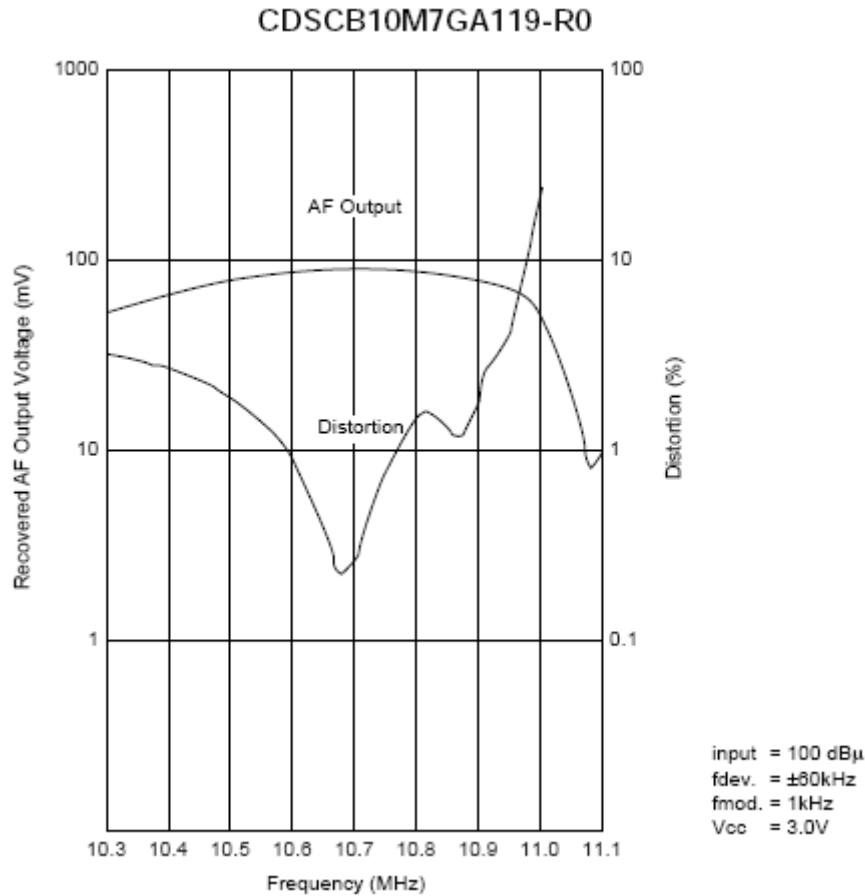

3.4.6 TR Switch

Using a TR switch allows a separate but individually optimized impedance match between the antenna and the transmit path or receive path. Transmit power and receive sensitivity can be degraded by as much as 3 to 5 dB if a common port configuration is used instead of a TR switch.

The recommended TR switch is Skyworks AS222–92 with a typical insertion loss of 0.3 dB and isolation of 27 dB at 900 MHz.

3.4.7 External Crystal for the TRF6903

The default clock crystal for the TRF6903 is Crystek 017119, 19.6608 MHz. The TRF6903 works with other clock frequencies from 9.5 to 20 MHz. Other crystals include Citizen CS10, HCM49 and HC49US, ECS–196.6–20–5P, SMI 97SMX, and ICM HC45U.

Table 3–6. Example Crystal Information: Crystek 017119

CHARACTERISTIC	VALUE
Overall tolerance	\pm 45 ppm
Operating temperature	40°C to +80°C
Load capacitance	12 pF
Shunt capacitance	2 pF
Drive level	100 μ W



Software Overview

This chapter describes the external control software used for RF test and evaluation. This chapter can be used as the Evaluation Software User's guide.

Topic	Page
4.1 Software Description	4-2
4.2 Software Setup	4-3
4.3 Setting Up and Testing a Wireless Link	4-10

4.1 Software Description

The external control software is used to evaluate the performance of the Dolphin chipset. It interfaces to the DBB03A using a UART interface as shown in Figure 1–2. The features provided by this control software are explained in the following sections.

The Dolphin demo kit is been provided with this Evaluation software to communicate with the DBB03A using a UART interface with a defined protocol. This host interface Protocol document is detailed in the *Dolphin host interface protocol definition* application report (TI Literature SWRA043).

Figure 4–1. Evaluation Software– Main Screen

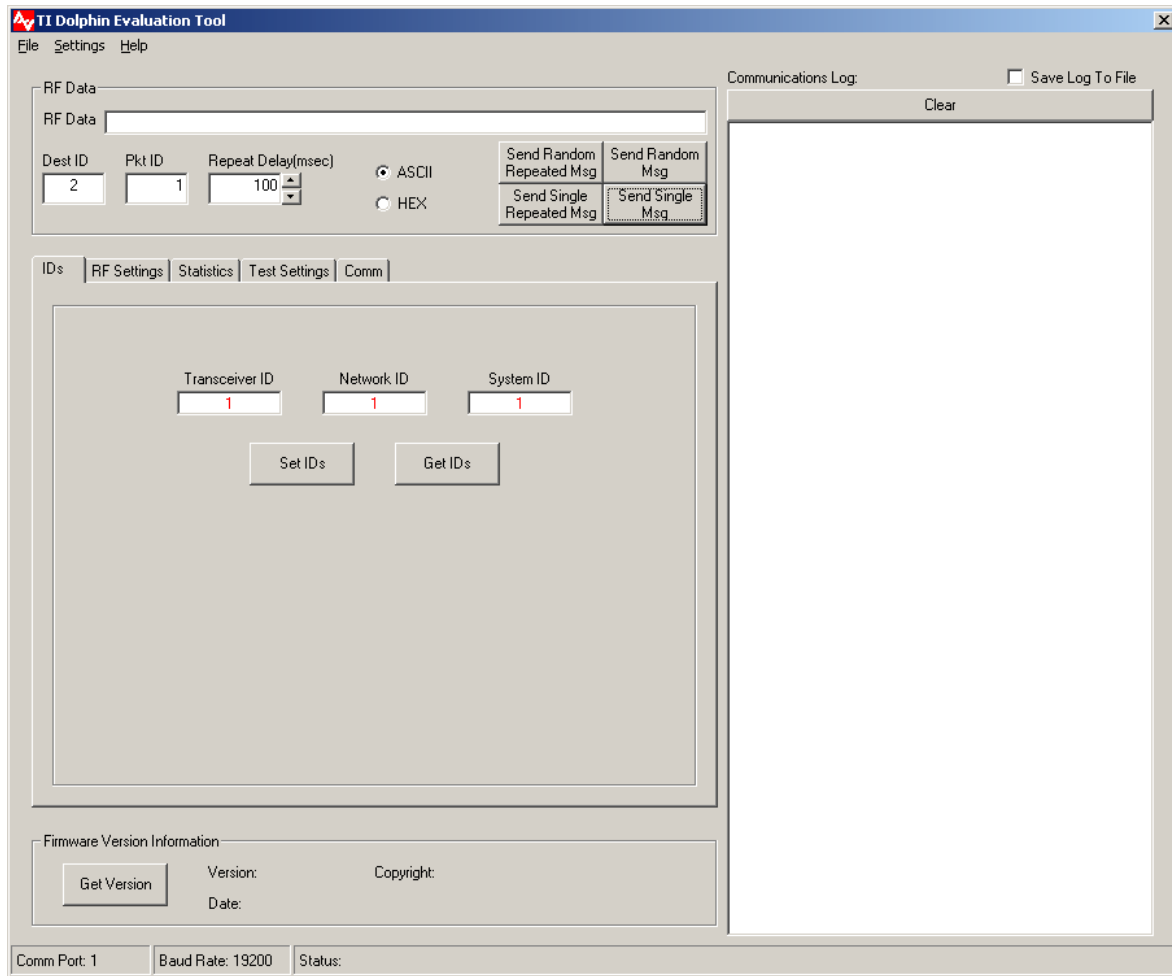

4.2 Software Setup

The following steps need to be followed to install the Dolphin Evaluation software.

- Download the Dolphin evaluation tool (swrc007.zip) from the Dolphin product folder at <http://focus.ti.com/docs/toolsw/folders/print/dolphin-wuart-ref.html>
- Execute the *DolphinEvalTool_Install_V2_0.exe* program.
- This starts an Install-shield wizard which will guide you through the rest of the setup process.
- Once the installation is complete, TI Dolphin Evaluation tool shortcut will be placed on the desktop.
- Invoke this shortcut to start Dolphin Evaluation tool. A screen shot of the evaluation software is shown in Figure 4–1.

If the Dolphin demo kit is powered up and connected to the serial port, the evaluation tool will *automatically* recognize the serial port. This serial port information will be displayed in the bottom left corner as shown in Figure 4–1. It is always recommended to invoke the evaluation tool *after* the serial cable is connected and the Dolphin demo kit is powered.

If not, before communication with the module is possible it is necessary to initialize the serial port. Pull down the “Settings” menu and click the “Communications” entry. The screen shown in Figure 4–2 will appear.

Figure 4–2. Communication Setup Screen Under Settings Pull Down Menu

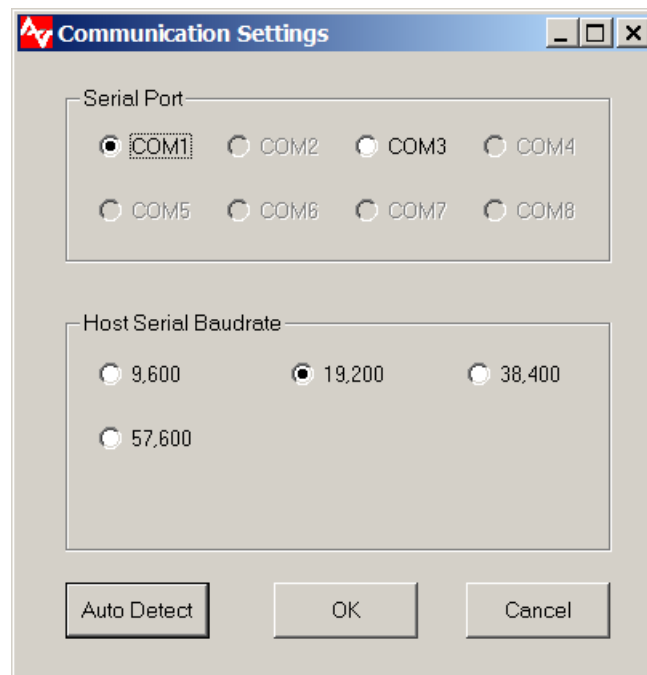

Click the “Auto Detect” button to cause the computer to search for the Dolphin module. When successful communication occurs the status line on the bottom

of the screen will update with the name of the COM Port, the baud rate at which it is communicating, and a status message.

By clicking the “Get Version” Button the module will return the firmware version number and date.

4.2.1 Setting Device Identification

The Dolphin chipset supports both point-point and broadcast networks and is configured through the *ID's* tab in the evaluation software. The evaluation software supports hierarchical device definition and is defined as follows. Each Transceiver is defined by a unique 16-bit ID and can be set by clicking the *Set Txcsr ID* button in the *IDs* tab. Each such transceiver has an associated 16-bit Network ID (set by clicking the *Set Network ID* button) and 16-bit System ID (set by clicking the *Set System ID* button) thus resulting in a 48-bit unique ID. Up to 65536 transceivers can be configured to operate in a system (with unique *System ID*). Only Transceivers with the same system and Network ID's will be able to communicate with each other. This is summarized below and is shown in Figure 4–1.

4.2.1.1 Transceiver ID

Set Transceiver ID – Set Transceiver ID (0–65534*)

Note: 65535 is reserved for general broadcast address

Get Transceiver ID – Returns stored value

4.2.1.2 Network ID

Set Network ID – Range 0 to 65535

Get Network ID – Returns stored value

4.2.1.3 System ID – Unique Manufacturers ID

Set System ID – Range 0 to 65535

Get System ID – Returns stored value

4.2.2 RF Settings

The RF Settings page can be accessed by selecting the *RF settings* tab in the software and is shown in Figure 4–3. The following features are provided in the RF settings page.

Enable or disable acknowledgements.

Set the number of message retries (range 0–20).

Set hop table – (range 0–14)

Note: All devices in the network must use the same hop table.

Set RF channel operating mode (single-channel or frequency hopping).

- Enable or disable receive all RF messages.
- Select TRF6903 power output attenuator setting
- Put the Dolphin unit in sleep mode (Both TRF6903 and DBB03A will be in standby mode)

Figure 4–3. RF Settings Screen

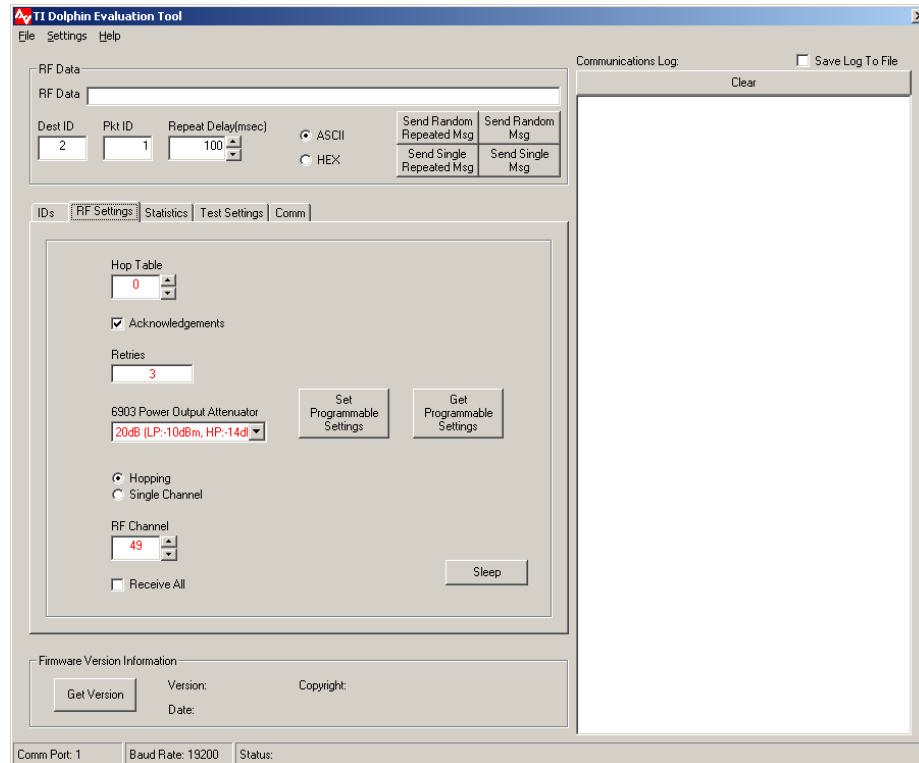

4.2.3 Statistics

The statistics page can be selected by clicking the *Statistics* tab in the software. This is shown in Figure 4–4. The statistics option can be used to evaluate the wireless link for packet success rates and throughput.

Figure 4–4. Statistics Settings Screen

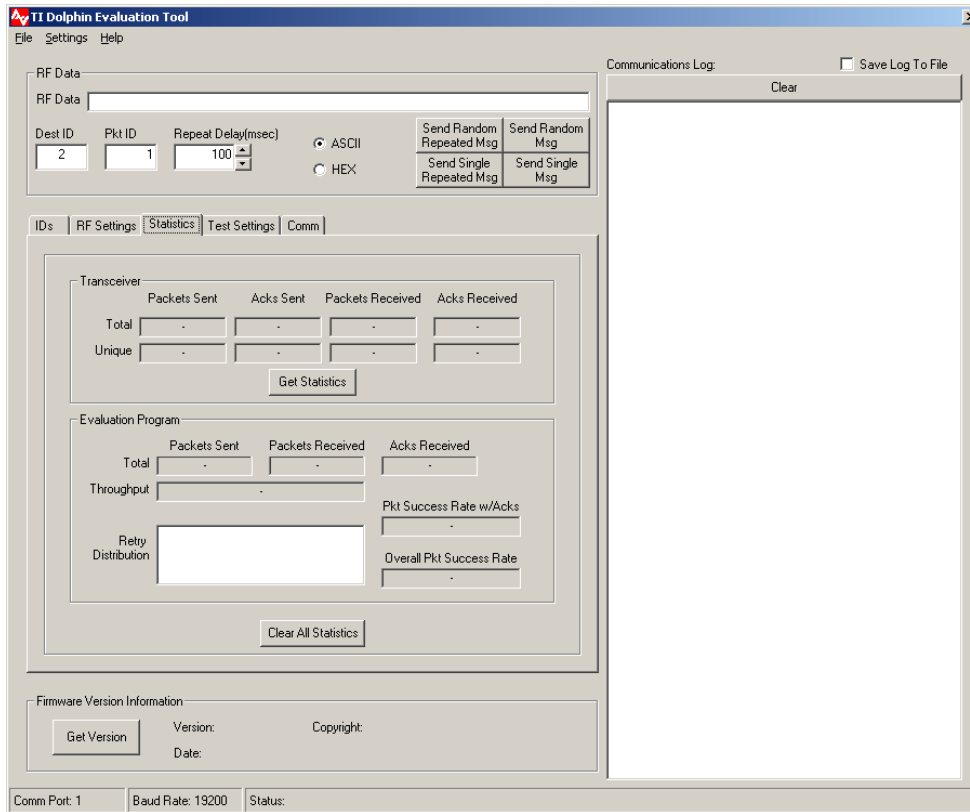

The various fields in the statistics page are explained below.

1) Packets Sent

Total: Total number of packets transmitted, including retries.

Unique: Number of message sessions initiated.

2) Acknowledgements (ACK) Sent

Total: Total number of acknowledgements sent by receiver.

Unique: Number of unique acknowledgements sent by receiver.

3) Packets Received

Total: Number of packets received, including retries.

Unique: Number of unique sessions seen by receiver.

4) Acks Received

Total: Total number of acknowledgements seen by transmitter.

Unique: Number of unique acknowledgements seen by transmitter

5) Evaluation Program Statistics

The window toward the bottom the page labeled *Evaluation Program* contains information about the integrity of the link between the host computer and the radio board.

4.2.4 Test Settings

This is shown in Figure 4–5. The Dolphin can be configured to be in the “test mode” to evaluate the RF performance of the TRF6903. The test mode provides an option to configure and program the TRF6903 registers. This allows the system designers additional flexibility to evaluate all the features of the TRF6903 for their application-specific needs. For detailed definition of the TRF6903 refer to the TRF6903 data sheet (*TI Document SWRS022*).

In order to evaluate the TRF6903 in test-mode, the Dolphin evaluation board needs to be connected to the Spectrum analyzer through an SMA connector.

Figure 4–5. Test Settings Screen

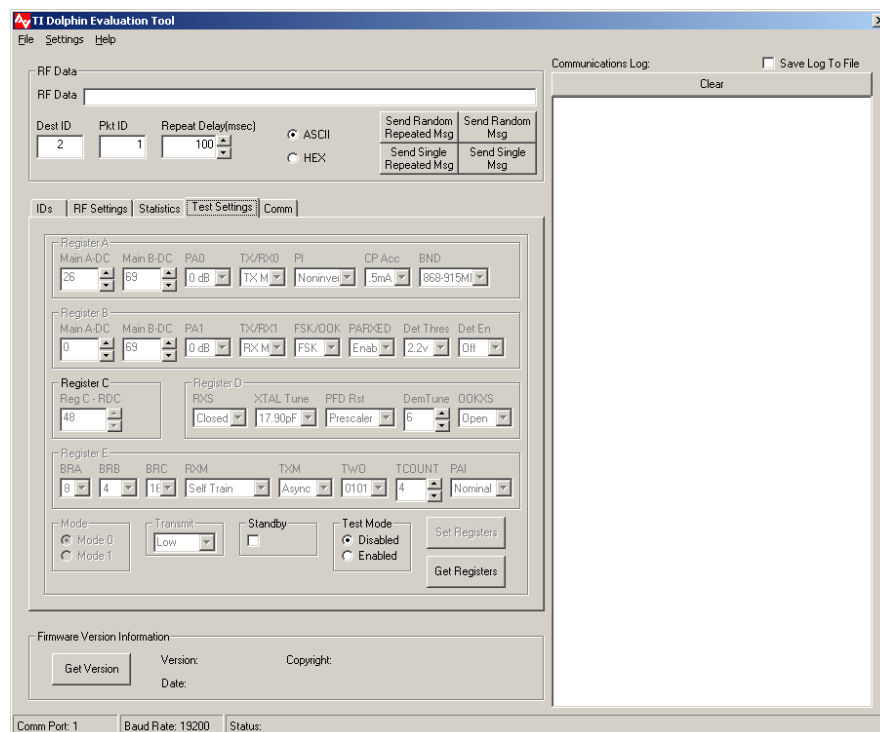

4.2.4.1 Transmit Test Plan

To evaluate the TRF6903 in transmit mode, the following steps are needed

- Connect the SMA connector (PA output) to the spectrum analyzer
- Go the test setting tab in the evaluation software as shown in Figure 4–5.
- Click *Test Mode* → *Enabled*
- Choose *Mode* → *Mode 0* (Default). All the TRF6903 register values are set to default values.
- Click *Set Registers*
- A CW signal at 915.0464 MHz is observed with a power level of 7 dBm in low power board and +20 dBm in high power board. See the TRF6903 data sheet (SWRS022) for more details on the TRF6903 register settings.

This is illustrated in Figure 4–6.

Figure 4–6. Test Settings Transmit Mode

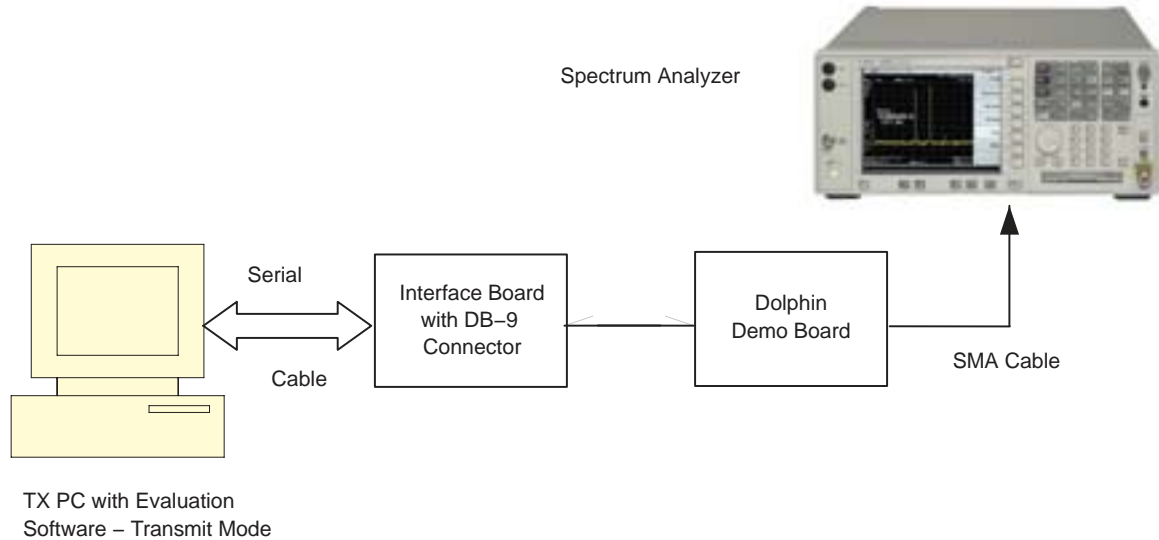

4.2.4.2 Receive Test Plan

To evaluate the TRF6903 in the receive mode, the following steps are required:

- 1) Connect the SMA connector (LNA input) to a RF signal generator (Rohde and Schwartz SMIQ07 for example).
- 2) Choose *Mode* → *Mode 1* (receive mode). By default the LO frequency is set to 904.3968 MHz.
- 3) Click *Set Registers*
- 4) Set the RF signal generator center frequency to $904.3968 + 10.7 = 915.0968$ MHz to obtain low-side injection.
- 5) Set the RF Power level to < -30 dBm to avoid saturating the LNA.
- 6) Set the modulation settings to 19.2 kHz and frequency deviation of 50 kHz.
- 7) Turn the RF power and the modulation ON.
- 8) A demodulated square wave at 19.2 kHz (38.4 kbps NRZ) can be observed at the RXDATA terminal of the TRF6903.

This is illustrated in Figure 4–7.

Figure 4–7. Test Settings Receive Mode

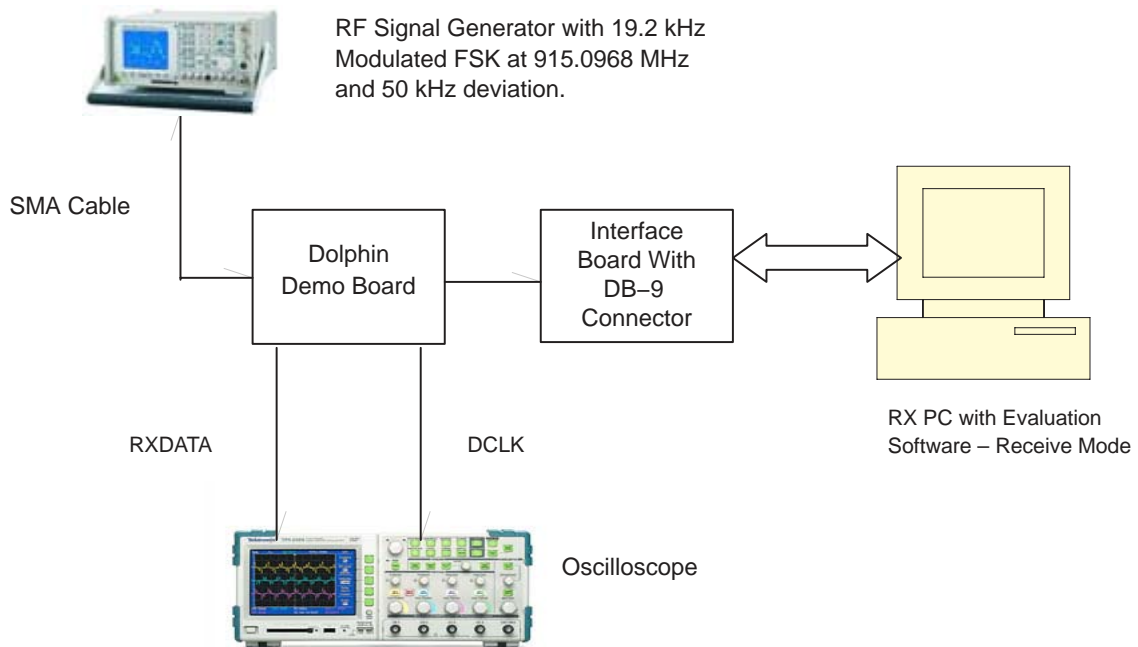

4.2.5 Communication Settings

The communication settings page can be selected by clicking the *Comm* tab in the software. This is shown in Figure 4–8. The serial port baud rate can be set by using this option.

Note:

Once the serial port baud rate is changed from the default value (19.2 kbps) the *Settings->Communications->AutoDetect* option has to be chosen to synchronize the baud rates between the evaluation software and the hardware UART of the DBB03.

Figure 4–8. Transceiver Bit Rate Settings Screen

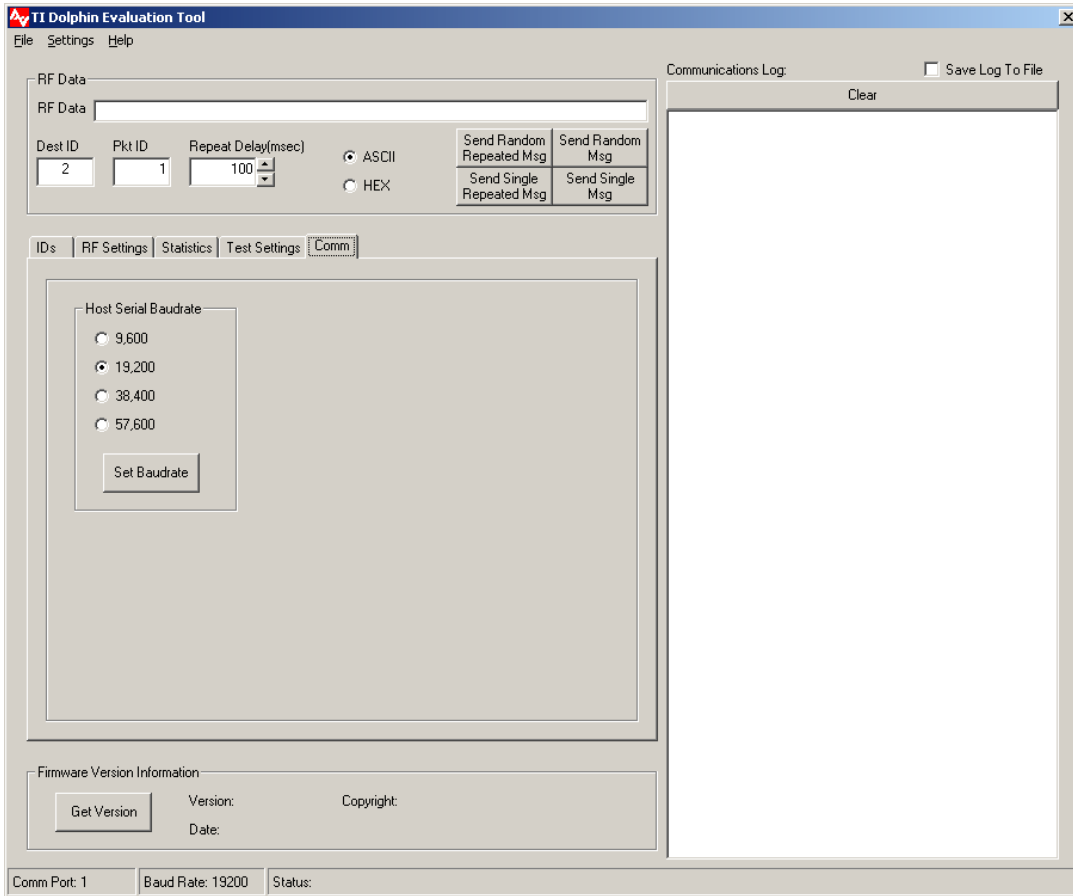

4.3 Setting Up and Testing a Wireless Link

Operational testing of the unit requires at least 2 units in order to establish a link. One unit will be the initiator and the other will be the responder. In order for a link to be established it is necessary to setup the transceiver identification numbers, hop tables, network identification, and system identification.

Link testing may be performed in either a single ended or a round trip fashion. This can help to differentiate between real world packet error performance and raw radio performance. *If Acknowledgement settings are not used then it's a single-ended test if not it's a round trip test.*

4.3.1 Single-Ended Test

Single ended performance will require 2 computers, since it will be necessary to read the statistics from each radio.

Start by setting the hop table, system identification, and network identification to match on both ends of the system as shown in Figure 4–9. If you are unsure about what values to use, a good default is hop table 0, and network and system ID's set to 1. Set different transceiver identification values for each radio. Values of 1 and 2 will suffice for testing. Figure 4–7 shows the correct setup screen for the initiating transceiver. The destination transceiver ID has

to be inserted in the *Dest ID* field. Also note that the *Acknowledgements* have to be disabled for a single-ended test.

Any message that is transferred between the host and the transceiver and from the transceiver back to the host is logged in the *Communications Log* window. Each message is fragmented into bytes represented in Hex format. Refer to the *Dolphin Host Interface protocol document (TI App Note SWRA043)* for detailed definition of each of these host messages. This message log can be saved to a file for further analysis. The “save log to a file” feature is very useful while analyzing the link performance of the system. This is further explained in Section 4.3.4.

Place the 2 units in physically separate locations and apply power to them. The statistics will clear when power is cycled, but they will need to be cleared manually after each test if power is not cycled.

Connect the PC serial port to one of the units and bring up the “IDs” screen. Type the transceiver ID number for the remote unit into the “*Dest ID*” field at the upper left of the screen.

4.3.1.1 Using Send Single Repeated message Option

Type a short message into the “*RF Data*” window. The message can be any text or numbers. If no message is entered it will not be possible to transmit. Set the “Repeat Delay” to 100 msec if it isn’t already set. Click the “*Send Single Repeated Msg*” button to start transmission. The radio will send one message every 100 msec until the “*Stop Repeat*” button is clicked.

The received data will be displayed in the *RF Data* window at the receiver side. The received data format can be chosen to be ASCII or HEX. Allow the test to run for some convenient amount of time and then stop transmission. Go to the “*Statistics*” screen to read the number of unique messages sent. Record this number and read the “*Packets Received*” statistic from the computer connected to the Receiving Transceiver. Link success is simply the ratio of the “*Packets Received*” to the “*Packets Sent*”.

This test will give the raw performance of the link in one direction without retries. It is a good indicator of the RF environment in which the radios are being used. High levels of noise or other products operating in the 900 MHz ISM band can cause lower packet success rates.

4.3.1.2 Using Send Random Repeated message Option

This option lets the user sends messages of random length (between 1 and 36 bytes). The message content is also randomly chosen. Since the message content is randomly chosen some non-printable characters are also generated. If the receive-side is programmed for data reception in ASCII mode, junk characters will be displayed in the RF data window. It is recommended that HEX option be chosen when receiving Random messages.

Figure 4–9. ID Setup for Single-Ended Link Test

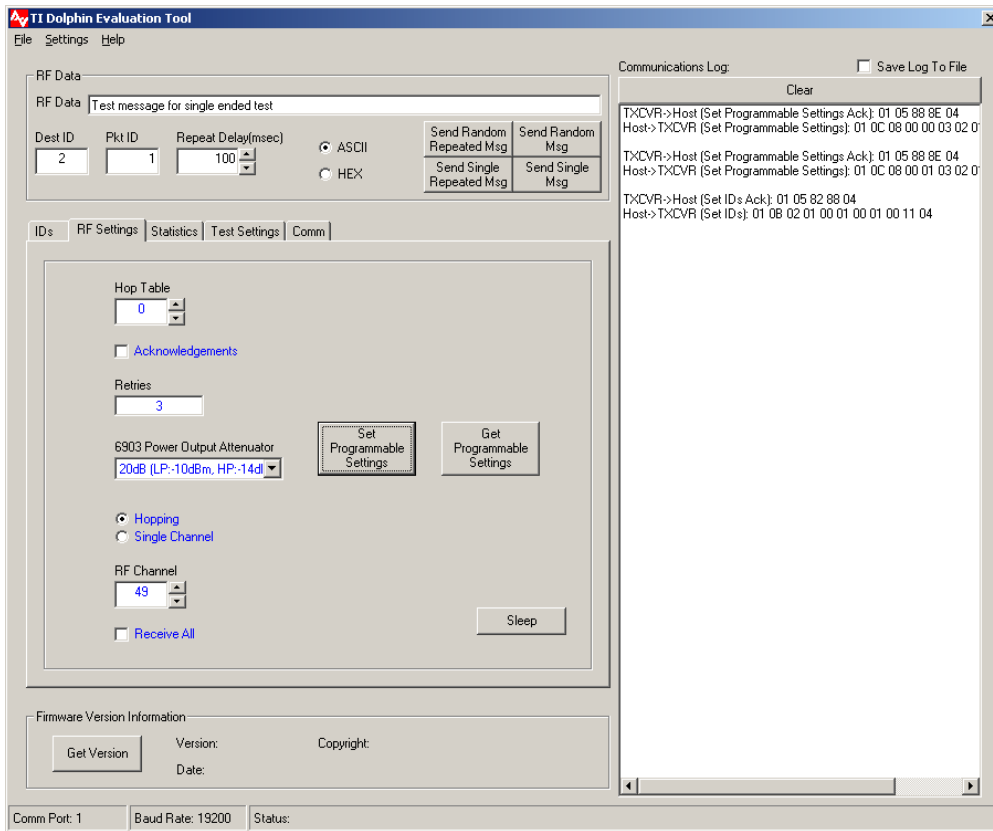

4.3.2 Round Trip Test

To test the ability of the system to retry messages in a noisy environment it is necessary to use a round trip test where the remote end can acknowledge receipt of packets. Use the setup screen as shown in Figure 4–9, but **enable** acknowledgements and retries as shown in Figure 4–10.

Perform the test in the same manner as the single ended test. Run enough transmissions to get a statistically valid sampling of the radio environment over a reasonable period of time.

Figure 4–10. ID Setup for Round-Trip Test

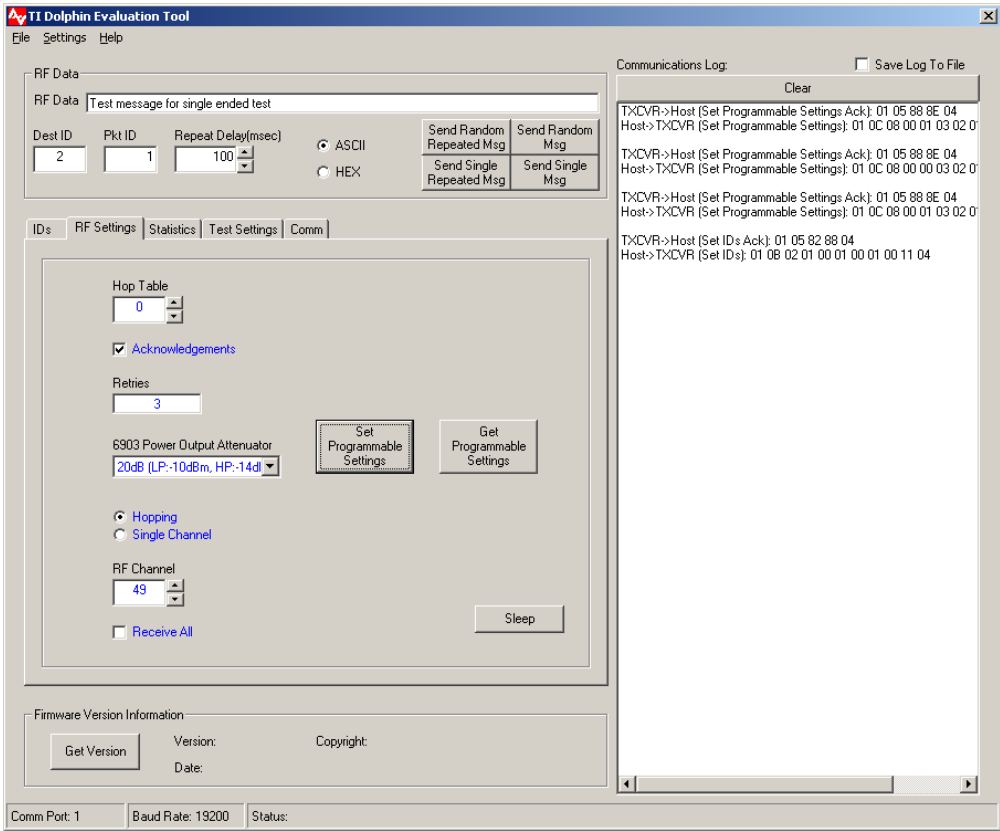

Look at the “Statistics” screen on the initiating radio to find the number of unique transmissions and the total number of transmissions. The total will likely be higher than the unique due to retried messages. The *Overall Packet Success Rate* and the *Packet Success rate with Acks* are defined as follows.

$$\text{Overall Packet Success Rate} = \frac{\# \text{ Acks} - \text{Received}}{\# \text{ Packets} - \text{sent}}$$

Packet Success rate with ACKS is

$$\frac{\# \text{ Acks} - \text{Received}}{(1 \times \# \text{ Packets} - \text{sent}) + (2 \times \#1\text{Retries}) + 3 \times (2\# \text{Retries}) + (4 \times \#3\text{Retries}) + \dots}$$

The Retries values are obtained from the *Retry Distribution* window in the *Evaluation Program statistics* section. It can be observed that if there are no retries the *Overall Packet Success Rate* is equal to the *Packet Success rate with Acks*.

4.3.3 Single Transmissions

A message may also be sent only once using the “Send Single Msg” button. The user should be aware that this function contains a feature to reduce network clutter and eliminate redundant messages. If a message is sent with this function, and it is successfully acknowledged by the remote end, it will not be

possible to send that same message again. The “*Pkt ID*” field must be manually updated to generate a new message that is different from the last message.

4.3.4 Save Communication Log to a File

In order to better keep track of the link performance of the Dolphin solution, the evaluation software provides an option to save the entire contents of the communication log screen onto a file. The information in the file is time-stamped so that the same file can be appended several times to generate a global log.

To enable logging the following steps needed to be followed.

- Power-up the Dolphin demo kit and start the evaluation tool.
- Check the *Save Log To File* option (top right corner of the evaluation tool) as shown in Figure 4–11.
- This then opens a Save dialog Box as shown in Figure 4–12. Provide the name of the log file. All the log files have an extension (.dlf). Any standard text editor like notepad can be used to view this log file.
- Start the communication by either sending a *single repeated message* or a *random repeated message*.
- Press the *Stop Repeat* button once enough packets are sent (400 packets is usually a good number)
- Press the *Get Statistics* button to display the statistics on the evaluation tool.
- Un-Check the *Save Log To File* option to stop logging.
- Open the log file name using Notepad or any text editor.

The same procedure can be repeated every time to store logs. By default once a filename is provided, the log file is appended every time communication happens. All the logs are time-stamped so that they can be distinguished. Logging to a different file is possible by selecting a new file name from the *File->New* option before logging. Logging to an existing file is possible by selecting the *File->Open* option

Figure 4-11. Enabling the Save Log To File Option

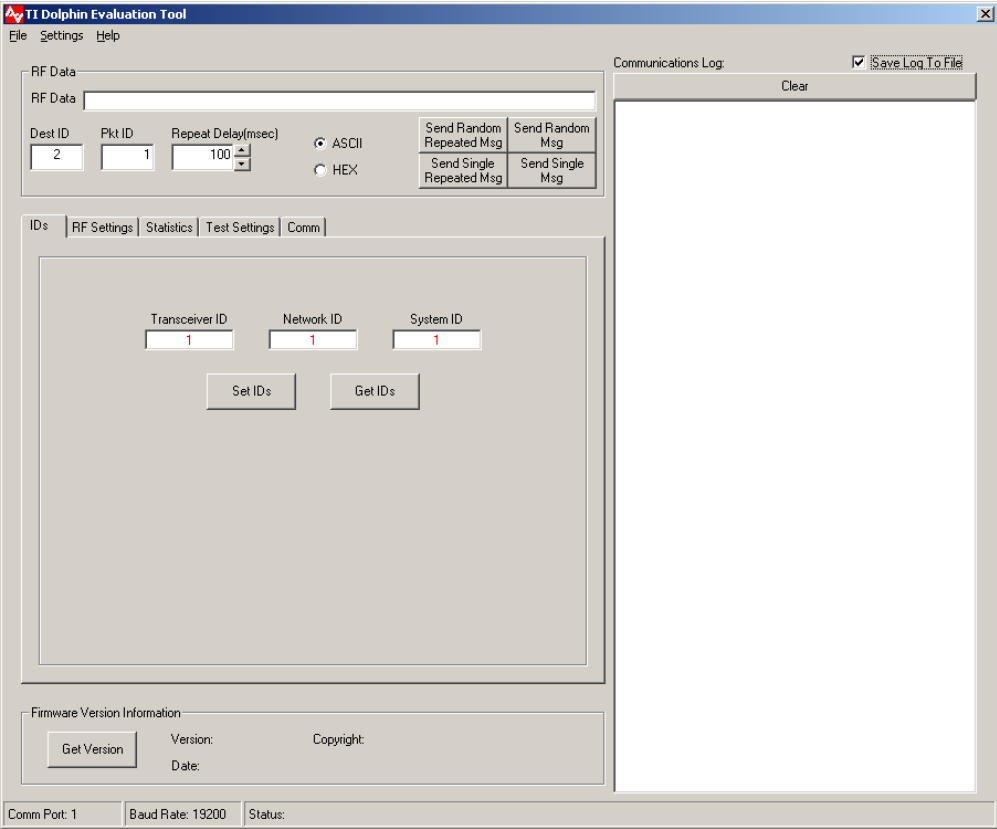
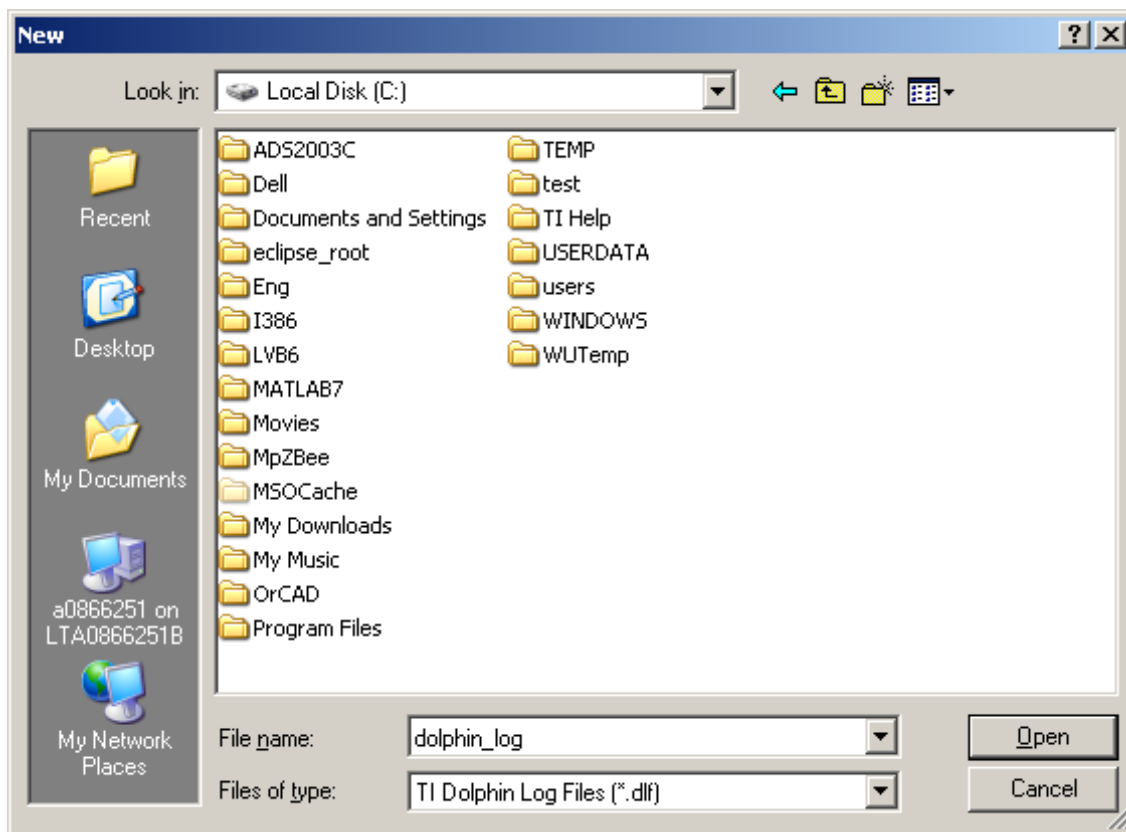

Figure 4–12. Saving the Log File



Protocol and Firmware Overview

This chapter describes the system level protocol along with the firmware implementation for the Dolphin demo kit.

Topic	Page
5.1 Protocol Overview	5-2
5.2 Firmware Overview	5-6

5.1 Protocol Overview

This section discusses the RF transmit and receive protocols implemented in the Dolphin firmware. The transmit and receive path logic diagrams are also presented.

5.1.1 RF Transmit / Receive Protocol Overview

The two modes of operation for the Dolphin chipset are single-channel mode and hop mode. The main difference between the two modes is the TX preamble length. Single channel mode requires considerably less preamble time since the RF Channel for communication is known.

Hop mode uses a 70-ms preamble which consists of 010101... sequence (see Figure 5–1). This preamble length allows the receive device 1.4 ms per channel (50 channels x 1.4 ms = 70 ms) to sync up with the transmit device. Once both devices are on the same channel through the receive device determining a valid preamble, a sync pattern occurs between the TX and RX device with a 00110011... sequence. After the devices are in sync, the TX device communicates with the RX device as stated in the host protocol document. Note that the next message to be communicated by the TX device occurs on another channel in the current mode of operation.

Figure 5–1. RF Overhead in Hop Mode



Single-channel transmit protocol (see Figure 5–2) is similar to the hop mode preamble with the exception of the preamble length. Since the RF channel is preselected, the preamble length required in single channel mode is 4 ms.

Figure 5–2. RF Overhead in Single-Channel Mode

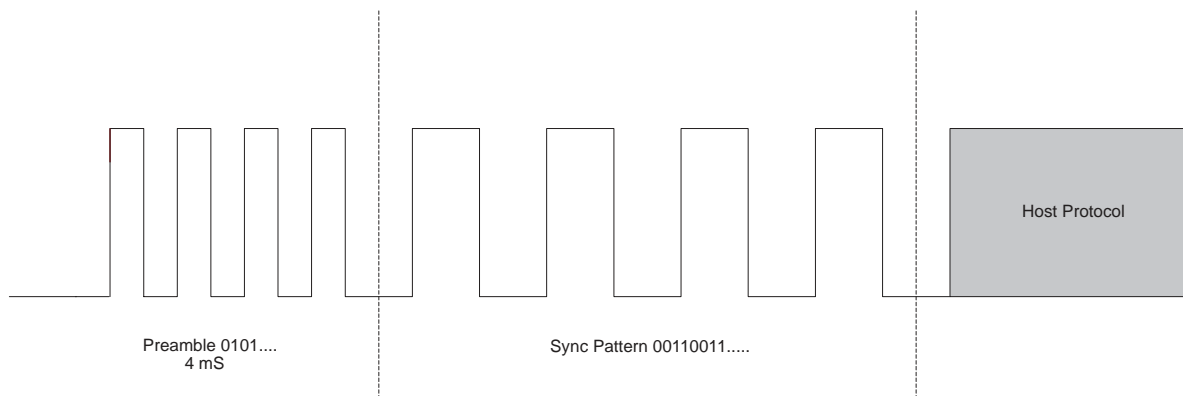

5.1.2 RF Transmit Logic Diagram

The RF transmit side logic diagram is shown in Figure 5–3. The logic diagram shows the various steps performed to transmit a host message from the evaluation software wirelessly over to the receiver. The RF receive side logic diagram is shown in Figure 5–4.

Figure 5–3. Transmit-Side Logic Diagram

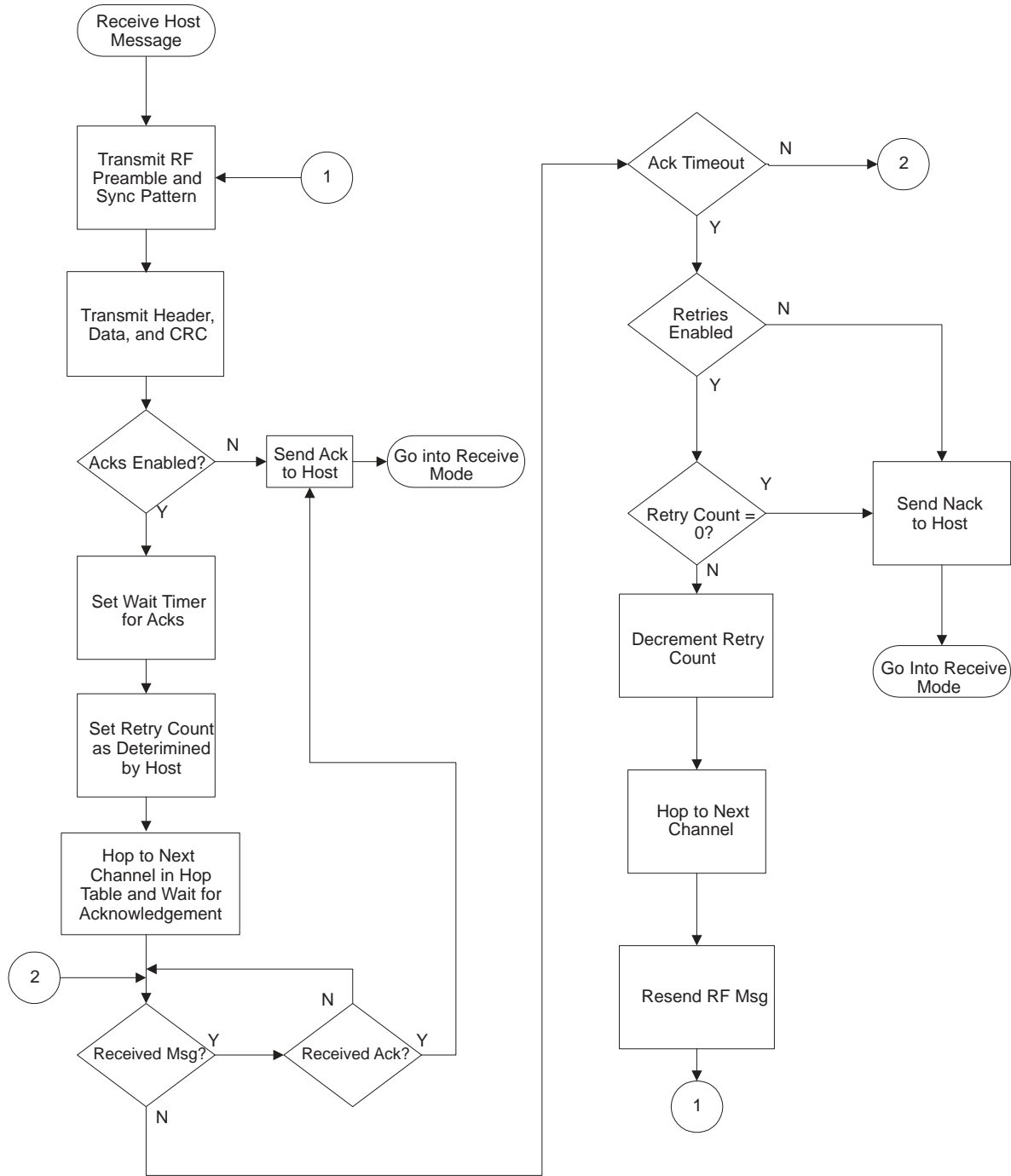

5.1.3 RF Receive Logic Diagram

Figure 5-4. Receive-Side Logic Diagram

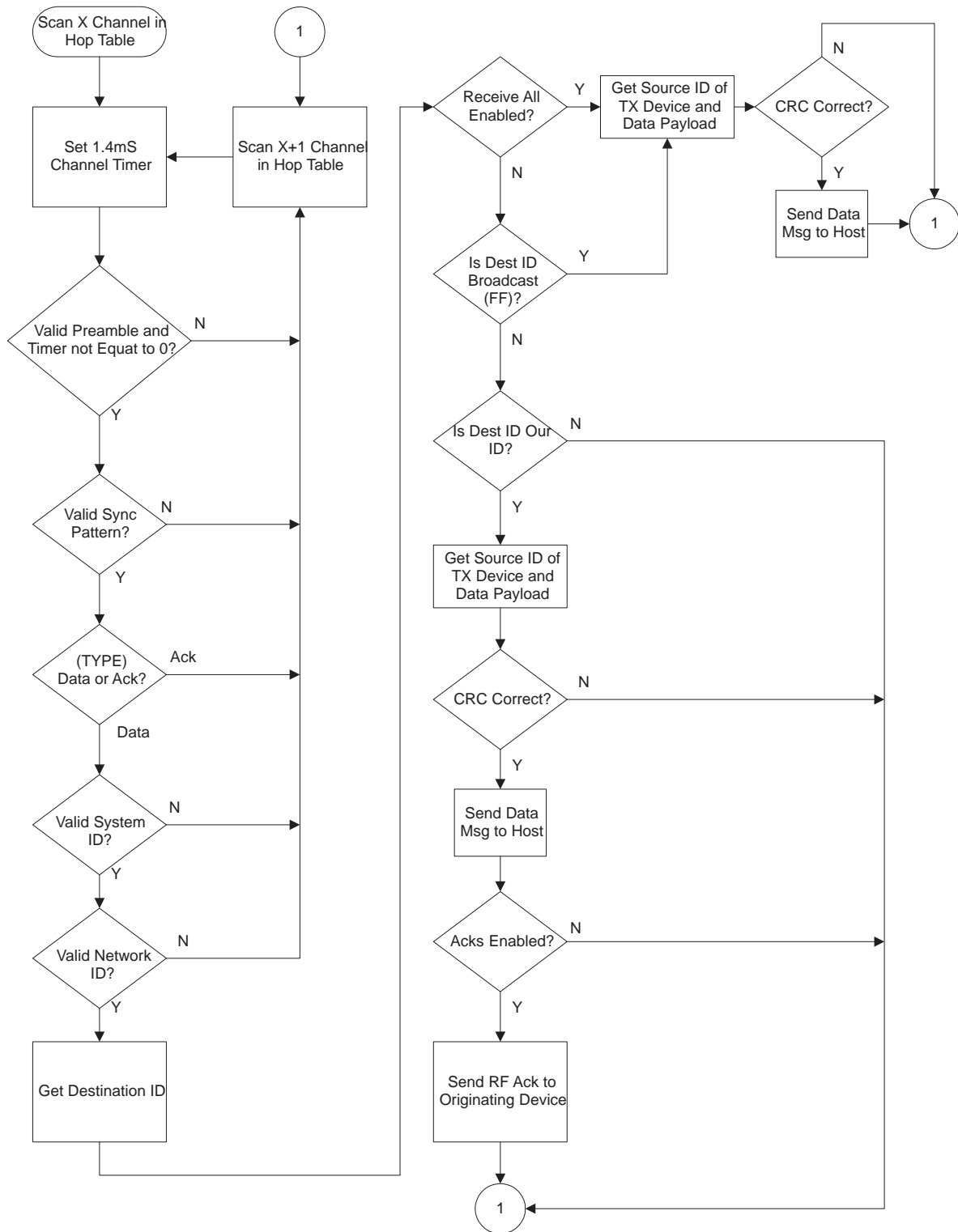

5.2 Firmware Overview

This section discusses parts of the firmware implemented in the Dolphin FHSS chipset solution.

5.2.1 Implementation of Frequency-Hopping Protocol

FHSS is an acronym for frequency-hopping spread spectrum. FHSS system implements a signal that hops in a random sequence from frequency to frequency as determined by firmware. The hop table selected determines the random sequence for the transmitter and the receiver. The Dolphin chipset firmware implementation specifics are described in the following paragraph and shown in Figure 5–5.

First, the transmit and receive devices must be set to identical hop tables. The originating device once activated to transmit transmits data on a random channel determined by firmware. The receive device scans each channel looking for the TX preamble consisting of a 0101... sequence. Once the receive device determines a valid preamble it remains on the valid channel. Once the originating device transmits the 70-ms preamble it sends the sync pattern with the sequence of 00110011... The receive device syncs up with the originating device and prepares to receive valid data. Upon receiving valid data the receiver hops to the next channel predetermined by firmware to transmit an acknowledgement to the originating device. The originating device goes into receive mode after transmission and listens for the acknowledgement on the next channel determined by firmware. Upon successful communication, the originating device passes to the host a successful transmission acknowledgement from the intended receiver. (Acknowledgements must be enabled)

Figure 5–5. Protocol Overview

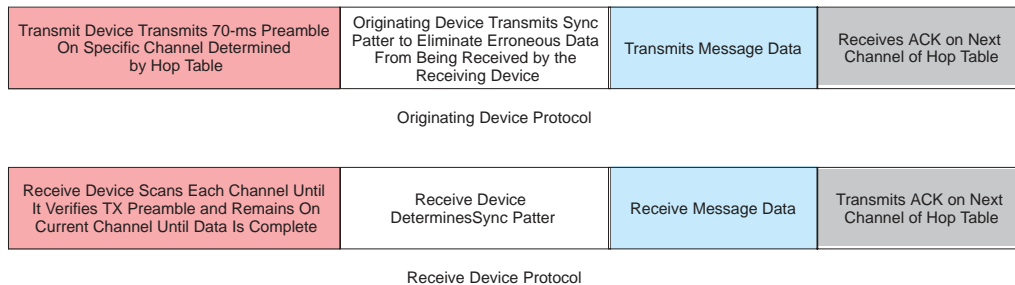

Applications

This chapter provides an overview of the architectures that Dolphin supports along with some examples of sample applications that are based on the Dolphin solution.

Topic	Page
6.1 Network Architecture	6-2
6.2 Applications	6-4

6.1 Network Architecture

This section discusses the different network topologies supported by the Dolphin chipset solution.

Dolphin supports the following network architectural topologies.

- Point-Point
- Broadcast

6.1.1 Point-Point Architecture

The point-point architecture can be configured into the following topologies:

- Star (See Figure 6–1)
- Ring (See Figure 6–2)
- Complete (See Figure 6–3)

Note:

The firmware on the Dolphin chipset supports the **Complete** point-point architecture. The Star and Ring topologies are subsets of the **Complete** topology and minor changes in the firmware needs to be done to implement them.

Note:

The star topology (see Figure 6–1) is a master-slave configuration. In the above illustration, the *Transceiver ID 0* is the master and the rest of the transceivers are slaves under the *System ID 1*. Slaves communicate with each other through the Master.

Figure 6–1. Star Topology

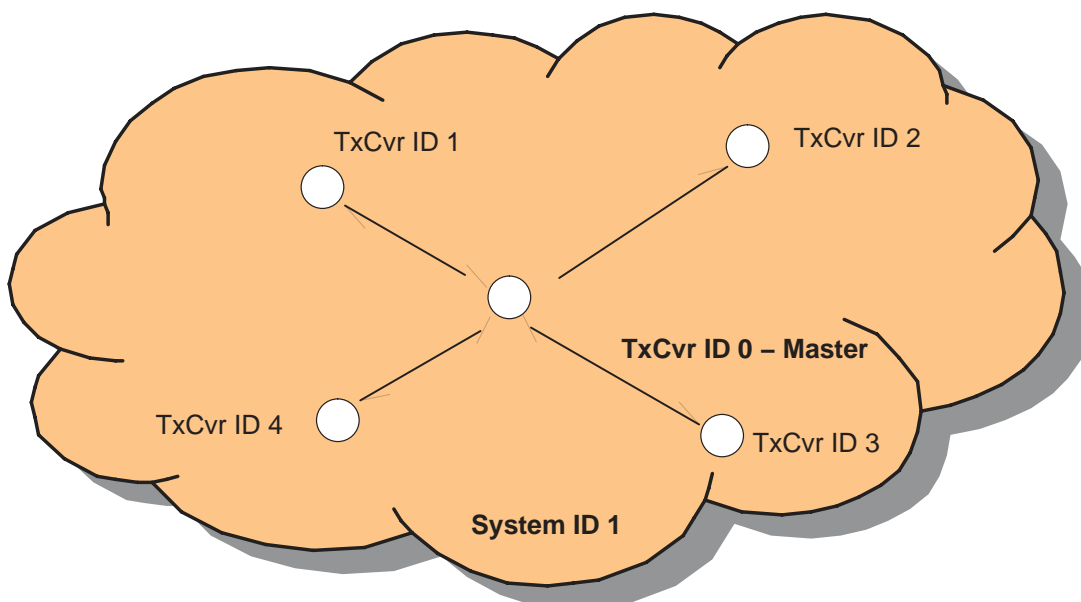

In the ring topology (see Figure 6–2), all the transceivers are connected in the form of a ring forming a closed network. There is NO central point or the master in the topology.

Figure 6–2. Ring Topology

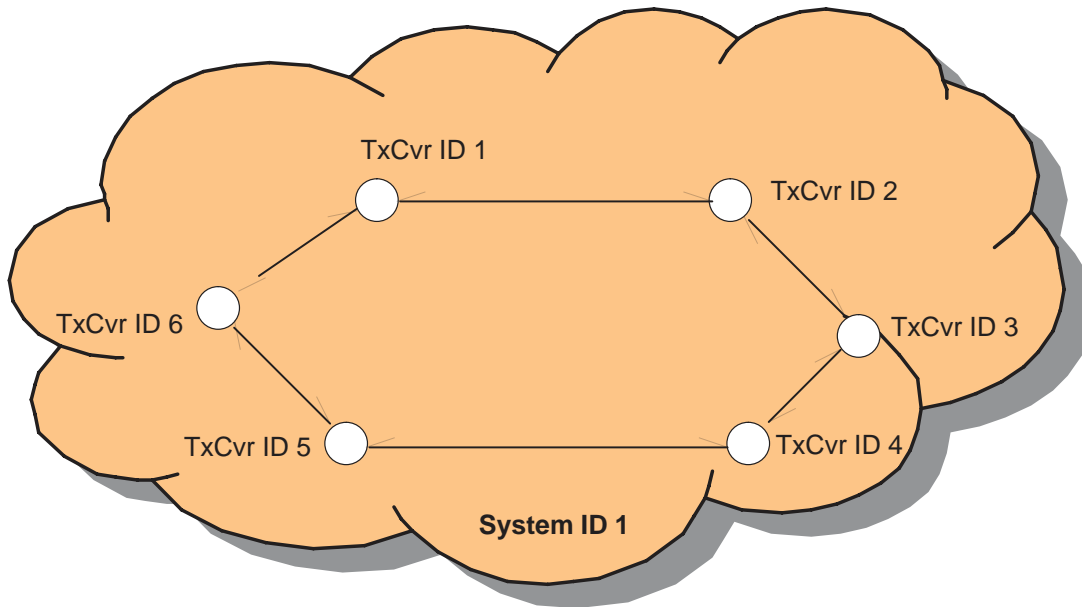

In the complete topology (see Figure 6–3), all the nodes are connected to each other and the system is fully connected. The star and ring topologies are subsets of the complete topology. The firmware for the Dolphin chipset supports complete point-point topology. The firmware needs to be customized for any other network topology.

Figure 6–3. Complete Topology

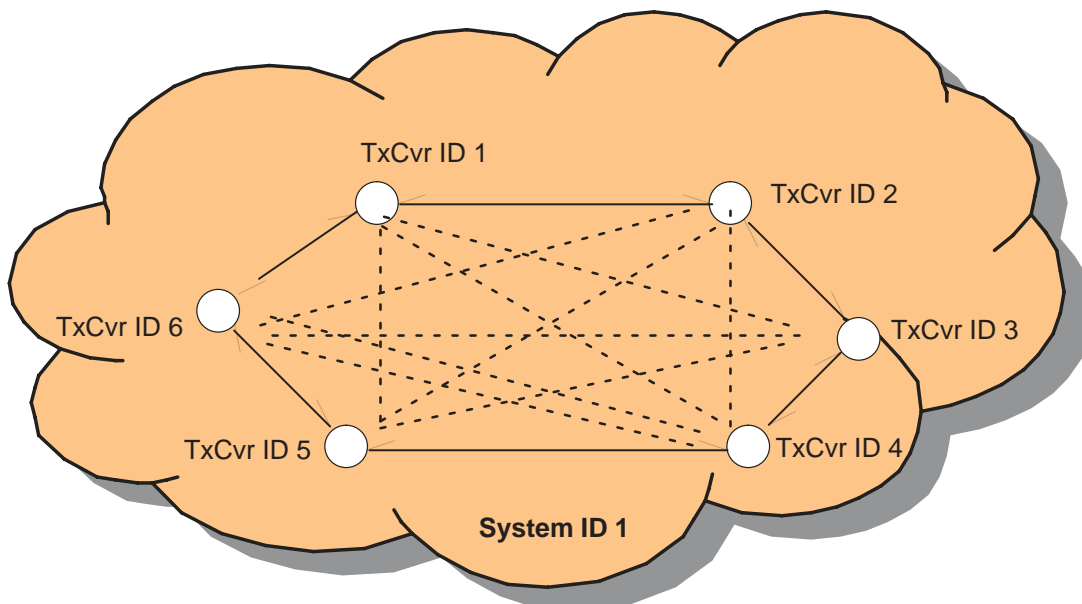

6.1.2 Broadcast Architecture

The Dolphin is designed to support broadcasting. This is enabled by setting the transceiver ID as 65535 in the evaluation program, *DestID* field. No acknowledgements are supported when broadcast is used. The architecture is shown in Figure 6–4.

Figure 6–4. Broadcast Topology

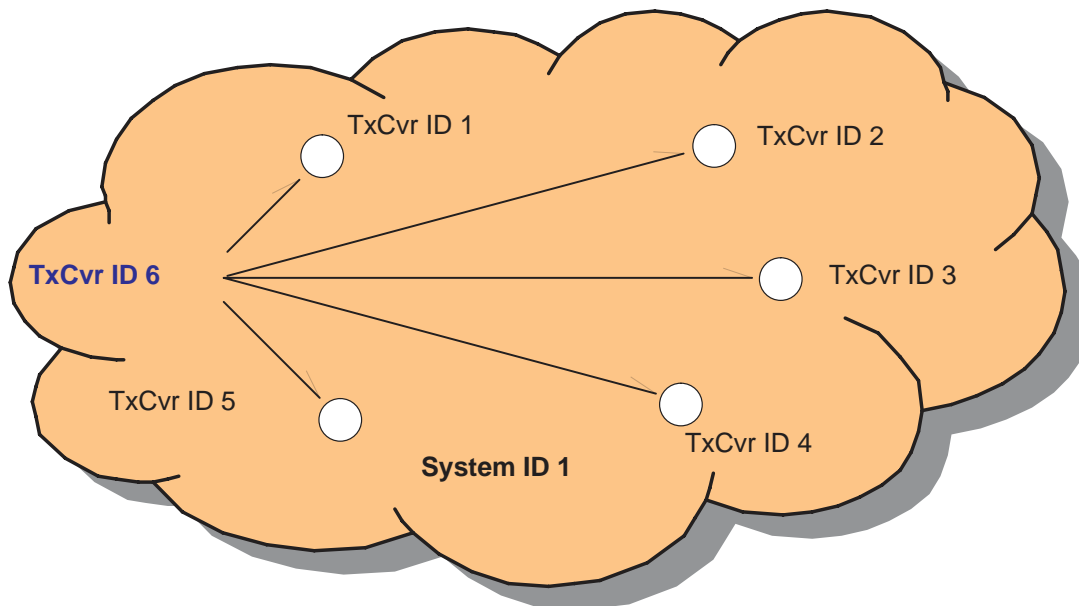

In the architecture above, *TxCvr ID 6* initiates the broadcast.

6.2 Applications

This section discusses wireless metering application based on the Dolphin solution.

6.2.1 Wireless Metering – AMR

Automatic meter reading, or AMR, is a fast growing sector of the metering industry. Increasing the speed and accuracy with which meter readings can be taken is the key to improving billing efficiency. There are various technologies which have been proven to be successful in multiple applications: wireless communication using radio frequency (RF) and inductive transmission through wireless contact devices, or touch pads are some of them.

Wireless metering is a facility to allow data collection from remote sites. The technology is particularly suited to automated meter reading for electricity, water, and gas utilities, but is equally suited to a wide range of remote monitoring and telemetry applications.

Automatic meter reading (AMR) technology enables the meter readers to read electric meters remotely, via radio signals. AMR meters are read by specially equipped vehicles, or handheld devices carried by the meter readers. They allow the metering company to provide accurate and timely meter reads each month, simply by driving or walking by one's residence.

An overview of the AMR system is shown in Figure 6–5.

Figure 6–5. Overview of the AMR System



The AMR system can be configured in many ways. Two of them are described below.

WALK BY

Readings are taken while walking along the route where the meters are located. The reader is equipped with a special transceiver (transmitter/receiver) unit and a hand-held terminal/PC loaded with software that enables him/her to read every meter in the route without having to approach it physically. An RF interrogating signal is sent and every meter within the reception range is activated and responds through a transmitter/receiver unit. The data is later downloaded into the PC in the central office and processed as desired by the software.

DRIVE BY

The transceiver is installed on a vehicle that is driven along the route where the meters are located. The process is identical to that of the *walk-by* configuration but the data collection is quicker.

An overview of the AMR system using the Dolphin solution is shown in Figure 6–6.

Figure 6–6. Wireless Metering (AMR) Application Using Dolphin Wireless

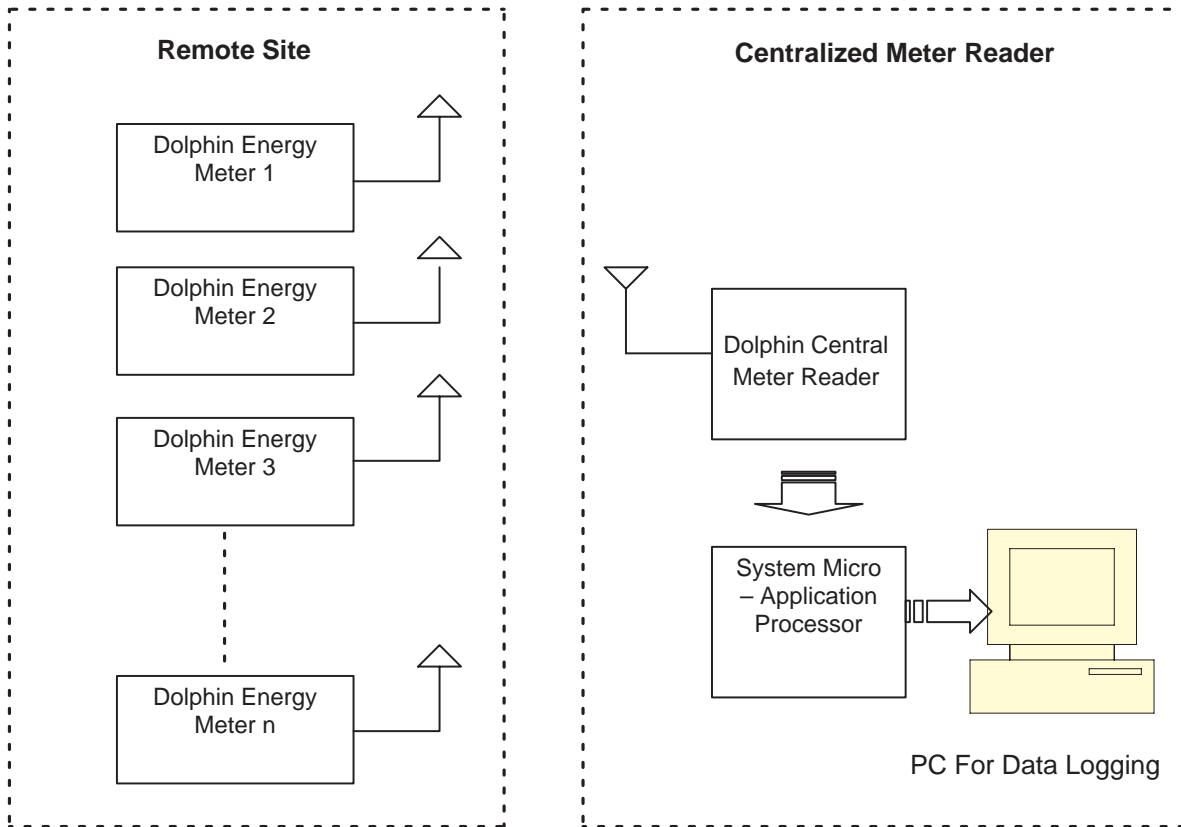

The Dolphin low cost radio transceiver is fitted to or integrated with existing metering or monitoring equipment and an interface to that equipment allows local data storage. The data is then transmitted to a central operations center for processing.

The energy meters at the remote sites are interfaced to the Dolphin. The DBB in the Dolphin chipset interfaces to the meter hardware and reads the meter value. This value is then transmitted wirelessly using the RF chip in the Dolphin chipset, the TRF6903 RF transceiver.

The periodicity of transmissions from the remote unit can be made programmable and can be set to occur from several times per hour to daily or even weekly according to the application. The remote units can go into standby mode when they are not transmitting (with a STANDBY current of 1 μ A) reducing power consumption and extending battery life dramatically.

RF Test Reports

The RF test reports for the Dolphin low power and the high power boards are tabulated in this section.

Topic	Page
A.1 RF Test Report for the Low-Power Board	A-2
A.2 RF Test Report for the High-Power Board	A-3

A.1 RF Test Report for the Low-Power Board

Mode	Parameter	Goal	t		deg 0	-40	-40	-40	25	25	25	85	85	85	95
			Supply V	V											
Standby	Standby current	4.0 max		0.05	0.08	0.11	0.03	0.10	0.10	0.10	0.10	0.62	0.77	0.77	1.11
Transmit	Transmit current	40 max	30.1	33.7	40.2	32.0	35.3	39.8	39.8	33.4	36.5	36.5	36.5	36.5	40.1
	Output power (15.247)	8.0	5.90	6.75	7.46	6.03	6.96	7.70	7.70	5.61	6.57	6.57	6.57	6.57	7.38
Transmit	f data 0	915.0464	915.0263	915.0300	915.0288	915.0430	915.0455	915.0455	915.0455	915.0525	915.0550	915.0550	915.0550	915.0550	915.0550
	f data 1	915.1472	915.1213	915.1238	915.1238	915.1335	915.1380	915.1380	915.1380	915.1463	915.1488	915.1488	915.1488	915.1488	915.1488
	f center	915.0968	915.0738	915.0769	915.0763	915.0883	915.0918	915.0918	915.0918	915.0994	915.1019	915.1019	915.1019	915.1019	915.1019
	p-p dev	100.8	95.0	93.8	95.0	90.5	92.5	92.5	92.5	93.8	93.8	93.8	93.8	93.8	93.8
	f center error	0	-23.0	-19.9	-20.5	-8.6	-5.0	-5.0	-5.0	2.6	5.1	5.1	5.1	5.1	5.1
	dev. error	0	-5.8	-7.0	-5.8	-10.3	-8.3	-8.3	-8.3	-7.0	-7.0	-7.0	-7.0	-7.0	-7.0
	20 dB mod. BW	<250	182.0	177.1	207.0	207.0	212.0	209.8	217.0	217.0	209.5	204.5	204.5	204.5	204.5
	Transmit current	27 typ	23.9	26.3	29.8	25.7	28.1	28.1	30.9	30.9	27.0	29.5	29.5	29.5	32.0
	Output power (15.249)	-1.0	-4.97	-3.61	-2.39	-4.40	-3.06	-3.06	-1.85	-1.85	-4.15	-2.76	-2.76	-2.76	-1.52
	20 dB mod. BW	<250	177.1	177.1	179.6	179.6	204.5	204.5	207.0	207.0	204.5	207.0	207.0	207.0	204.5
Receive	Receive current	23 max	15.3	16.5	17.3	17.5	18.8	19.6	19.6	19.1	20.6	20.6	20.6	21.3	
	Sensitivity	-98	-100	-100	-100	-101	-101	-100	-100	-99	-99	-99	-99	-99	
	LO power level		-96.77	-96.48	-97.76	-98.90	-97.70	-97.70	-96.40	-96.40	-96.36	-97.60	-97.60	-94.08	
	LO frequency	904.3968	904.3758	904.3786	904.3786	904.3923	904.3943	904.3943	904.3946	904.4020	904.4038	904.4038	904.4038	904.4043	
	LO f error	0	-21.0	-18.2	-18.2	-4.5	-2.5	-2.5	-2.2	-2.2	5.2	7.0	7.0	7.5	

- Notes:**
- 1) Unit 7, Revision A3 used for all tests. Component value changes listed below
 - 2) IF filter bandwidth = 330 kHz
 - 3) C27 = 27 pF, C28 = 22 pF, Cint = 17.9 pF
 - 4) RXS = D<19> = 1 = Closed
 - 5) Both LED resistors: R26 = R27 + NP
 - 6) uC section powered with a separate supply.
 - 7) PC interface removed for all current measurements

SPECTRUM ANALYZER SETTINGS:

Output power: 200 MHz
 f data 0 and 1: 500 MHz
 20 dB Mod. BW: 1 MHz
 Receive LO: 100 kHz

A.2 RF Test Report for the High-Power Board

Mode	Temperature (°C)	-40	25	25	85	85	Units
	Supply Voltage (V)	3	3.6	3.6	3	3.6	
	Parameter						
Transmit	Transmit current	132.8	179	147.9	136.8	170.5	mA
	Output power	20.7	22.7	20.6	20	22	dBm
	f center	915.07166	915.07136	915.08234	915.08452	915.08835	MHz
	f center error	-25.1	-25.4	-14.5	-12.3	-10.4	kHz
	20 dB mod. BW	198.8	195	206.3	196.3	206.3	kHz
Receive	Receive current	19.2	20.9	23.1	23.6	24.6	mA
	Sensitivity	-101	-101	-100	-100	-100	dBm

- Notes:**
- 1) Unit 502, Revision B used for all tests.
 - 2) IF filter bandwidth = 330 kHz
 - 3) PC interface removed for all current measurements.

Equipment Settings:

Output power: HP8596E Spectrum Analyzer, 200-MHz span
 f center: HP 53310A Modulation Domain Analyzer 20 μs/division, 50 kHz/division
 20 dB Mod. BW: HP8596E Spectrum Analyzer, 1-MHz span, video averaging on

FCC Prescan Results

The Dolphin low power and high power boards were prescanned for FCC compliance and passed the prescan in both transmit and receive mode.

Topic	Page
B.1 Low-Power Board FCC Prescan Results	B-2
B.2 High-Power Board FCC Prescan Results	B-3

B.1 Low-Power Board FCC Prescan Results

B.1.1 SUMMARY

The Dolphin low power board passed an FCC prescan in transmit mode with shielding.

B.1.2 SETUP

A 2.9 inch, 22-gauge solid strand wire antenna was used for all testing. The length was determined empirically using a vector network analyzer (HP 8753E). A minimum return loss of 17 dB was achieved across the 902-MHz to 928-MHz band. The antenna was orientated in the same direction as the longer dimension of the board. Note that, the above minimum return loss was achieved with the antenna also orientated in the same direction as the shorter dimension of the board.

The transceiver was only tested in transmit mode between 0.9 – 6 GHz at the maximum supply voltage of 3.6 V, at a single carrier frequency of 915.1 MHz. The transceiver was orientated with the antenna perpendicular to the floor. This operational mode, supply voltage, orientation, carrier frequency, and frequency range represents the highest compliance risk. All combinations of the above test variables are examined in a full certification of a final product.

The transceiver was tested at full output power (0-dB attenuation setting) as a frequency hopping spread spectrum transmitter under FCC Part 15.247. The transceiver was also tested at low output power (20-dB attenuation setting) as non-spread spectrum transmitter under FCC Part 15.249.

A calibrated receive antenna and an EMI receiver (HP8546A and HP 85460A) were used to measure the radiated electric field at a 3-meter distance. The device rotational angle and receive antenna height was varied to determine the maximum radiated fields. For measurements above 1 GHz, an additional 1-GHz high pass filter was added to the EMI receiver to prevent overloading the front-end while measuring the low radiated signal levels of the harmonics.

B.1.3 RESULTS

The measurement results are tabulated on the next page. The first table shows the radiated field at the fundamental for different power level settings. Note that the 15.249 limit is 94 dB μ V. The radiated output at the middle power level (10-dB attenuation setting) is 6 dB over the Part 15.249 fundamental signal limit.

The second table includes the radiated emissions at the harmonics. Entries for example < 44 indicate that no emissions at the particular harmonic were observed below the indicated analyzer noise floor level. In all cases, the analyzer noise floor level was at least 6 dB below the limit. Finally, the levels of the radiated harmonics above 6 GHz were measured at a one meter distance. All emissions were below the noise floor of the analyzer.

Table B-1. Fundamental Emissions: (15.249 limit = 94 dB μ V/m)

A (dB)	Conducted P (dBm)	Measured E (dB μ V/m)
0	7	109.1
10	-2.5	99.9
20	-12.2	90.5

Table B-2. FCC Part 15.247 – Maximum Power (A = 0 dB)

			Vertical Polarization			Horizontal Polarization		
	f (MHz)	E-Field Limit	E-Field	Angle	Height	E-Field	Angle	Height
1	915	125.2 dB μ V/m	109	154	1	99	151	1
2	1830	20 dBc	60	29	1	49	9	1
3	2745	54 dB μ V/m	48	160	1	45	0	1.6
4	3660	54 dB μ V/m	< 44			NM		
5	4575	54 dB μ V/m	< 46			NM		
6	5490	54 dB μ V/m	< 48			NM		

Note: NM = Not measured

Table B-3. FCC Part 15.249 – Minimum Power (A = 20 dB)

			Vertical Polarization			Horizontal Polarization		
	f (MHz)	E-Field Limit	E-Field	Angle	Height	E-Field	Angle	Height
1	915	94 dB μ V/m	91	160	1	NM		
2	1830	54 dB μ V/m	40	23	1	< 38		
3	2745	54 dB μ V/m	< 43			NM		
4	3660	54 dB μ V/m	< 44			NM		
5	4575	54 dB μ V/m	< 46			NM		
6	5490	54 dB μ V/m	< 48			NM		

Note: NM = Not measured

B.2 High Power Board FCC Prescan Results

B.2.1 SUMMARY

The Dolphin high power board passed an FCC prescan in transmit mode with shielding.

B.2.2 SETUP

A 3.1 inch, 22-gauge solid strand wire antenna was used for all testing. The length was determined empirically using a vector network analyzer (HP 8753E). A minimum return loss of 12 dB was achieved across the 902-MHz to 928-MHz band. The antenna was orientated in the same direction as the shorter dimension of the board.

The transceiver was tested in transmit mode between 0.9 – 5 GHz at the maximum supply voltage of 3.6 V, at a single carrier frequency of 915.1 MHz. The transceiver was orientated with the antenna perpendicular to the floor.

This operational mode, supply voltage, orientation, carrier frequency, and frequency range represents the highest compliance risk. All combinations of the above test variables are only examined in a full certification of a final product.

The transceiver was tested at full output power (0-dB attenuation setting) as a frequency hopping spread spectrum transmitter under FCC Part 15.247.

A calibrated receive antenna and an EMI receiver (HP8546A and HP 85460A) were used to measure the radiated electric field at a 3-meter distance. The device rotational angle and receive antenna height was varied to determine the maximum radiated fields. For transmit mode measurements above 1 GHz, an additional 1-GHz high-pass filter was added to the EMI receiver to prevent overloading the front-end while measuring the low radiated signal levels of the harmonics.

B.2.3 RESULTS

The measurement results are tabulated on the next page. The first table shows the radiated field at the fundamental at the maximum power level settings.

Table B-4. FCC Part 15.247 – Transmit Mode, Maximum Power (A = 0 dB)

	Mode	f (MHz)	Limit	d (m)	Vertical Polarization			Horizontal Polarization		
					E-Field (dB μ V/m)	Angle (deg)	Height (m)	E-Field (dB μ V/m)	Angle (deg)	Height (m)
1	CW	915.1	24 dBm	3	123.9	256	1.1	119.3	335	1.5
2	CW	1830.2	20 dBc	3	45.3	199	1.2	41.7	0	1.1
3	Hopping	2745.3	54 dB μ V/m	3	47.1	0	1	43	95	1.3
4	CW	3660.4	54 dB μ V/m	3	48.6	220	1.3	44.1	120	1
5	CW	4575.5	54 dB μ V/m	3	50.5	302.5	1	52	321	1

Note: Hop set 15 (five channels) used hopping modes to test the third harmonic. This hop set should only be used for FCC testing.

B.2.3.1 FCC Part 15.109 – Receive Mode LO and Harmonics

The local oscillator and all harmonics were at least 6 dB below the 46.4 dB μ V/m limit.

Range Tests

The Outdoor Line of sight Range test results for the Dolphin Low Power and High Power boards are presented in this Appendix. A simple wire antenna (See Section B.1.2) was used for range testing.

The range test results are tabulated in Table C-1.

Table C-1. Range Test Results

BOARD	MAXIMUM TX POWER (dBm)	RX SENSITIVITY (dBm)	LINK BUDGET (dB)	RANGE (Feet)	RANGE (Mile)
Low Power	7	100	107	1050	0.2
High Power	20	100	120	5500	1

Topic	Page
C.1 Low-Power Board Range Results	C-2
C.2 High-Power Board Range Results	C-3

C.1 Low-Power Board Range Results

This is shown in Figure C-1. It can be observed that more retries results in better range at the cost of additional power consumption and increased transmit duty cycle.

Figure C-1. Low-Power Board – Outdoor Range Results

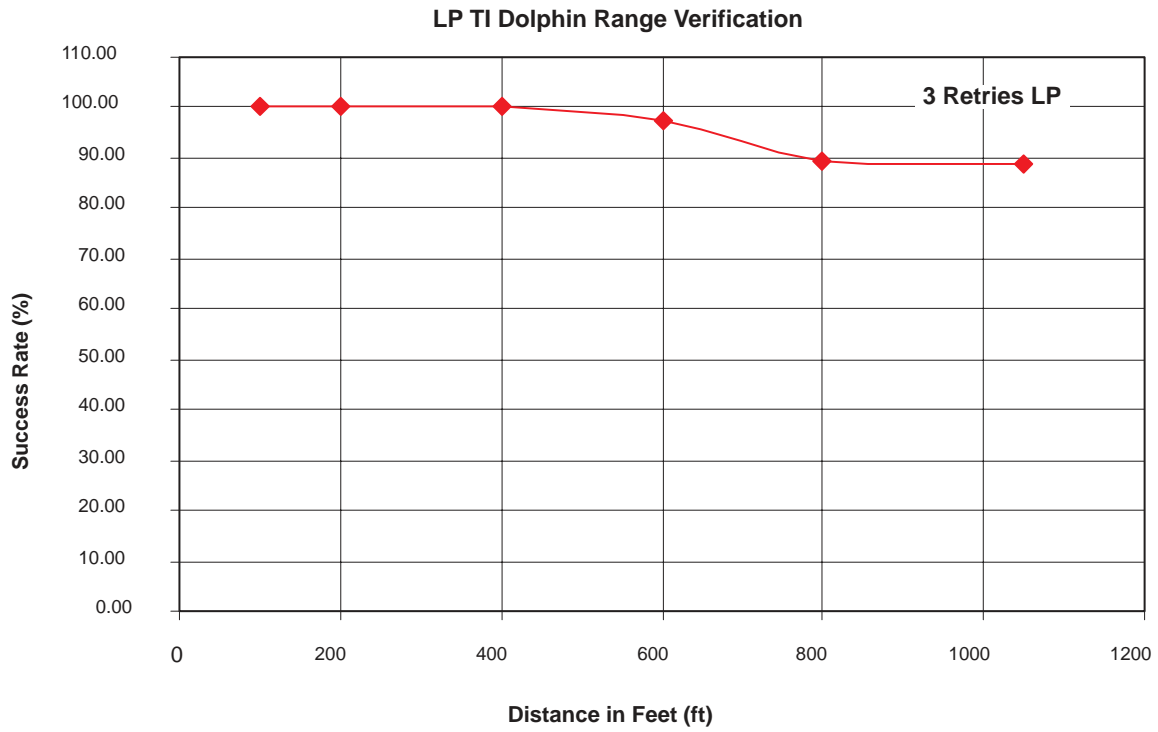

C.2 High-Power Board Range Results

This is shown in figure C-2.

Note:

Since the range tests were done in an outdoor mobile environment, the transmit and receive units were 3.0V battery powered. Thus the transmit power was about +20 dBm. If the units are powered using a +3.6V supply the transmit power is 3 dB better (+23 dBm) yielding significantly better range. Based on calculations the expected range at 3 dB higher output power will be approximately 1.4 mile (40% increase in range)

Figure C-2. High-Power Board – Outdoor Range Results

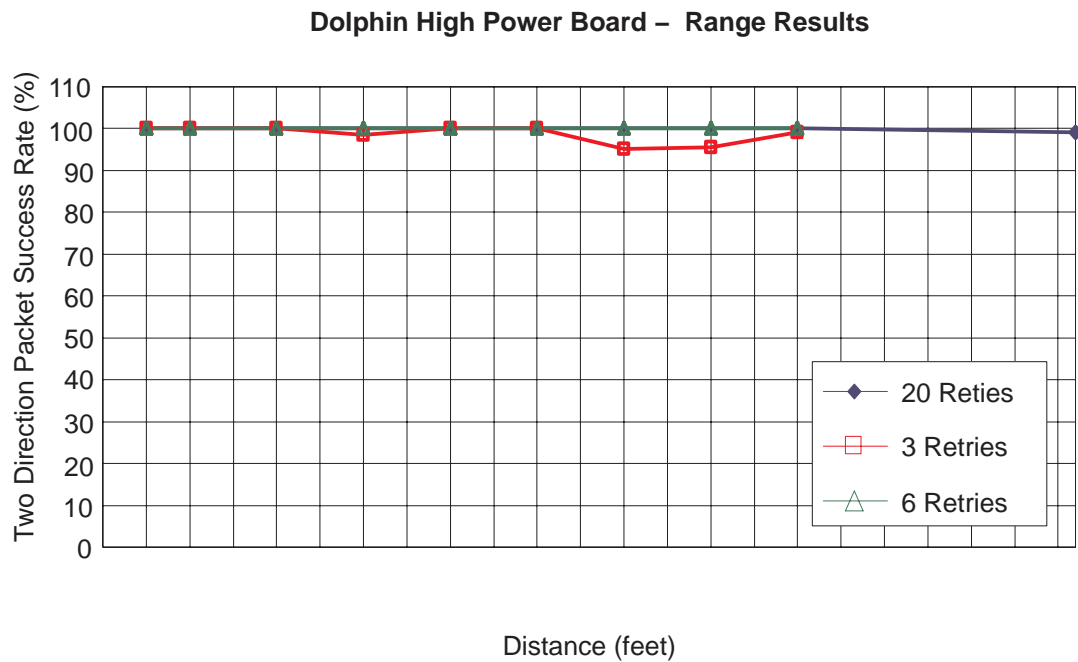

The Dolphin HP solution typically achieves a maximum range of 1 mile line-of-sight outdoors. However, the actual range is highly dependant upon the environment and, in harsh environments where there are many obstacles or interference, the range could be much lower.



Dolphin Bit Rate (Data Rate) Vs Throughput

Topic	Page
D.1 Dolphin Bit Rate (Data Rate) Versus Throughput	D-2

D.1 Dolphin Bit Rate (Data Rate) Versus Throughput

Bit Rate (or Data rate) is defined as the speed at which bits are sent over-the-air.

In Dolphin this Bit rate is fixed at 38.4 kbps (38400 bits/sec).

The Dolphin protocol is detailed in the graph below.

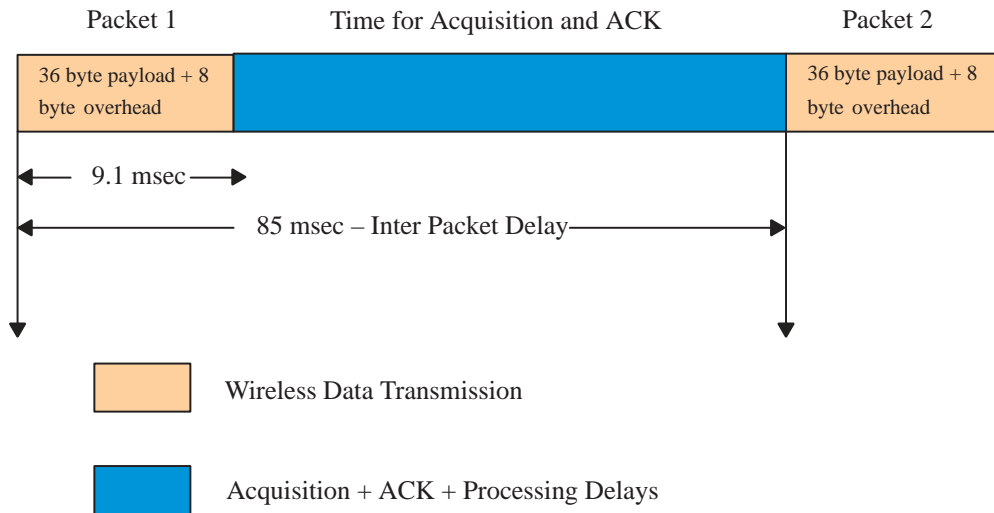

It takes at least 85 msec before another packet can be sent via Dolphin.

It is recommended that the inter packet delay be a few msec higher than this absolute requirement. The Dolphin Evaluation Tool for example uses 100 msec inter-packet delay for example purposes.

This 85 msec consists of

1. Time needed to transmit the 36 bytes (maximum) packet + overhead 8 bytes (44 bytes at 38.4 kbps = 9.1 msec)
2. 70 msec needed for acquisition
3. 4 msec needed for ACK
4. Processing delays in the micro

The Throughput of the system is defined as the amount of data bytes (payload) sent per second. In the case of Dolphin, 36 payload bytes are sent every 85 msec, which translates to a throughput of 3.39 kbps.

Throughput and bit rate (data rate) are two different entities.

Almost all RF transceivers define only the bit rate because the throughput of the system is highly application dependant.