

Features

- 3535 UVC LED
- ROHS and REACH Compliant
- MSL 3 qualified according to J-STD 020
- ESD 8KV

Applications

- Medical applications
- Industrial facility applications

Description

The IN-C35PUDTDU1 is a low-power UVC LED. It is a SMD type LED which can be used in various applications.

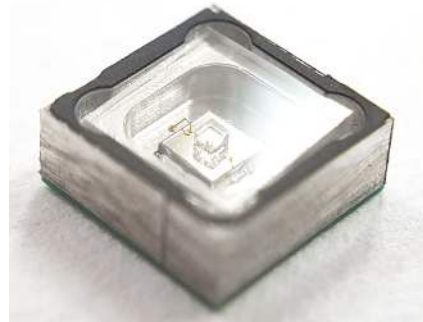

IN-C35PUDTDU1

Recommended Solder Pattern

(Suggest Stencil t=0.12 mm)

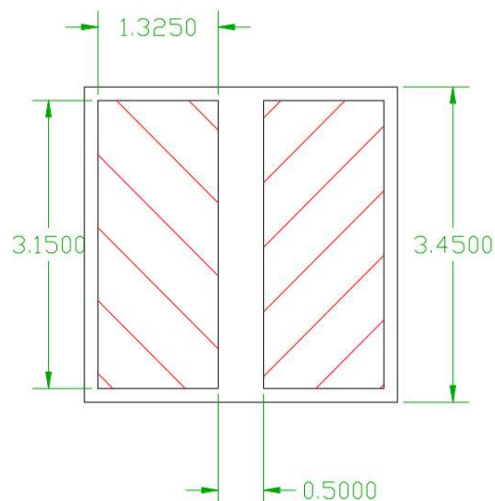

Figure 1. IN-C35PUDTDU1 Recommended Solder Pattern

Note:

All dimensions are in millimeters.
Tolerance is ± 0.13 mm unless other specified.

Package Dimensions

(All dimensions are in mm, tolerance is $\pm 0.13\text{mm}$)

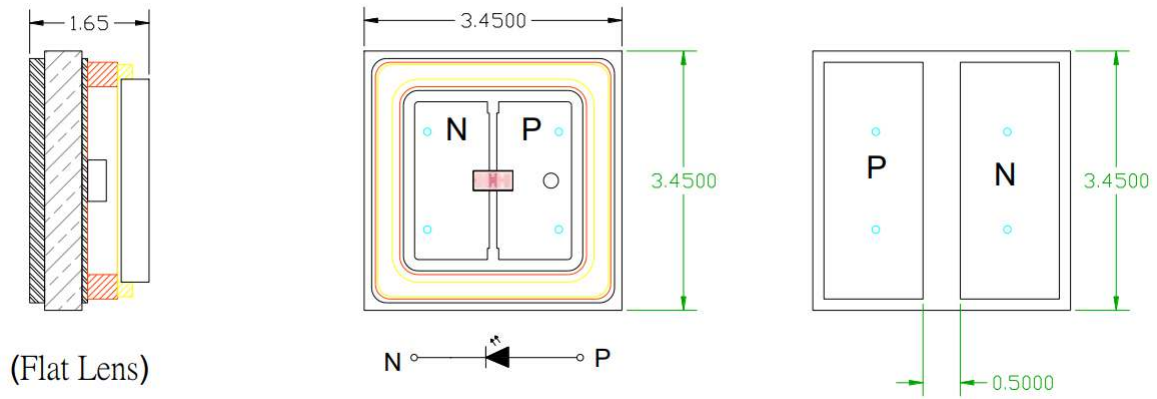

Figure 2. IN-C35PUDDU1 Package Dimension

Absolute Maximum Rating at 25°C

Characteristics	Symbol	Min.	Typical	Max.	Unit
DC Forward Current ¹	I_F			20	mA
Forward Voltage	V_F	5.5	6.5	8.0	V
Junction Temperature ³	T_j		60		°C
Storage Temperature Range	T_{stg}	-40	-	80	°C
Operating Temperature	T_{opr}	-10	-	50	
Soldering Temperature	T_{sol}		245		°C
Thermal Resistance Junction / Solder Point	R_{th}		55		°C/W
Viewing Angle ⁴	$2\theta_{1/2}$		125		Deg

Notes:

1. For other ambient, limited setting of current will depend on de-rating curves.
2. When drive on maximum current , T_j must be kept below 65°C
3. Viewing angle($2\theta_{1/2}$) $\pm 10^\circ$

ESD Precaution

ATTENTION: Electrostatic Discharge (ESD) protection



The symbol above denotes that ESD precaution is needed. ESD protection for GaP and AlGaAs based chips is necessary even though they are relatively safe in the presence of low static-electric discharge. Parts built with AlInGaP, GaN, or/and InGaN based chips are STATIC SENSITIVE devices. ESD precaution must be taken during design and assembly. If manual work or processing is needed, please ensure the device is adequately protected from ESD during the process.

Please be advised that normal static precautions should be taken in the handling and assembly of this device to prevent damage or degradation which may be induced by electrostatic discharge (ESD).

Electronic-Optical Characteristics

Relative Spectral Power Distribution

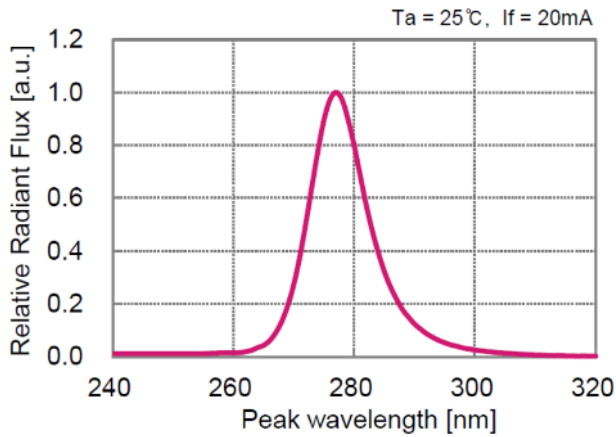

Forward Current vs. Forward Voltage (Ta=25°C)

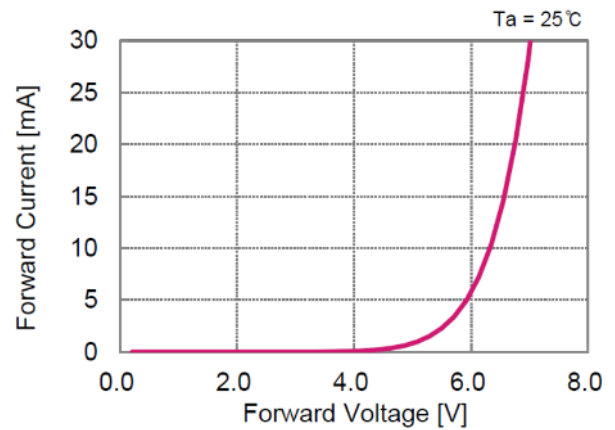

Relative Radiant Flux vs. Forward Current (Ta=25°C)

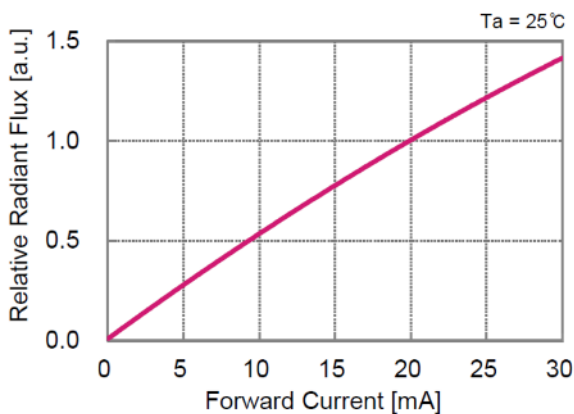

Relative Radiant Flux vs. Ambient Temperature (If=15mA)

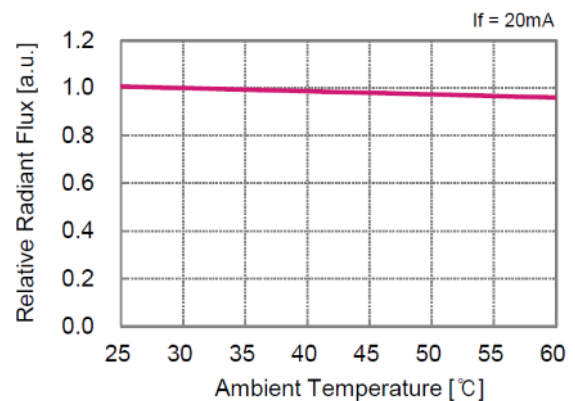

Relative Radiant Flux vs. Peak wavelength

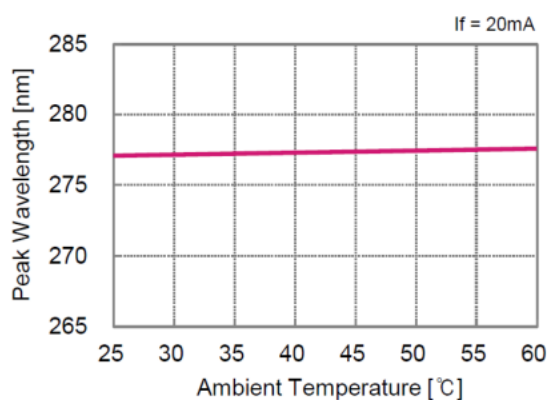

Derating

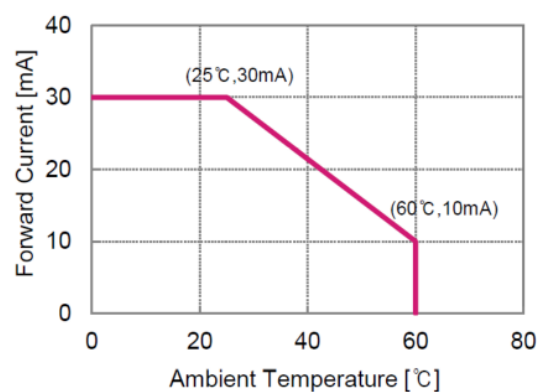
Notes:

 Viewing angle (2θ_{1/2}) ± 10°

Typical Characteristic Curves – Radiation Pattern

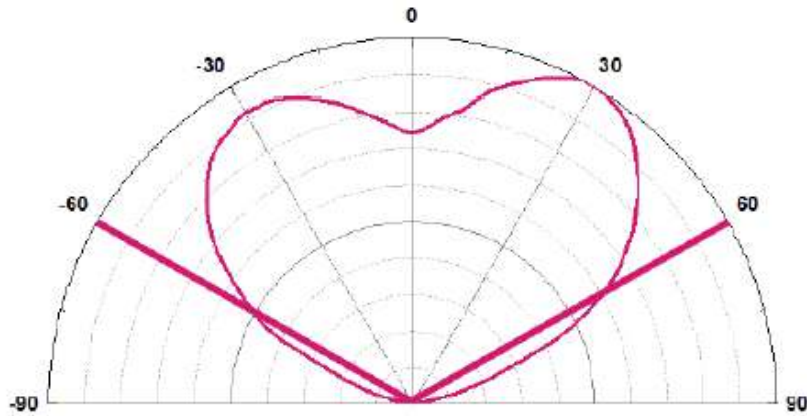

Ordering Information

Peak Wavelength Range	Beam Angle	Forward Voltage(V)		Part Number
		Min	Max	
U1: 270~285nm	125°	5.5	8.0	IN-C35PUDTDU1

Notes:

1. Forward voltage (VF) $\pm 0.5V$, Radiometric Power (Po) $\pm 15\%$.

Label Specifications

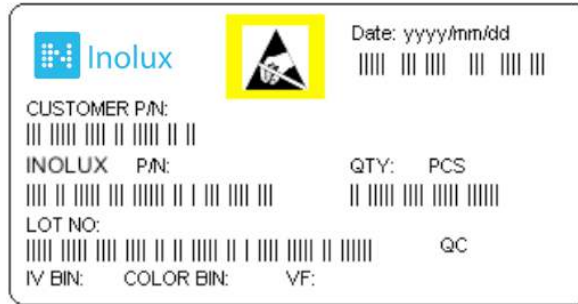

Inolux P/N:

I	N	-	C	3	5	PUD	T	D	U1	-	X	X	X	X
			Material	Package		Variation	Orientation	Current	Color		Customized Stamp-off			
Inolux SMD			C = Ceramic Type	35PUD = 3.5 x 3.5, 125 Deg.			T = Top Mount	D=20mA	U1 = 270-285nm					

Lot No.:

Z	2	0	1	7	01	24	001
Internal Tracker	Year (2017, 2018,)				Month	Date	Serial

Forward Voltage Binning

		Voltage		unit: V@20mA	
Peak Wavelength	Bin Code	Min	Max		
U1 270nm-285nm	A	5.5	6.6		
	B	6.5	8.0		

Notes:

1. Binning current is 20 mA

Radiant flux (Power) binning

Bin Code (20mA)	Min. Po (mW)	Typ. Po (mW)	Max. Po (mW)
P1	1.5	-	3.0

Notes:

1. Binning current is 20mA

Peak wavelength binning reference table

Bin code (20mA)	Min. Wp (nm)	Max. Wp (nm)
W280	270.0	285.0

Notes:

1. Peak-wavelength (Wp) tolerance: $\pm 2.0\text{nm}$
2. Testing Current 20mA

Reflow Soldering

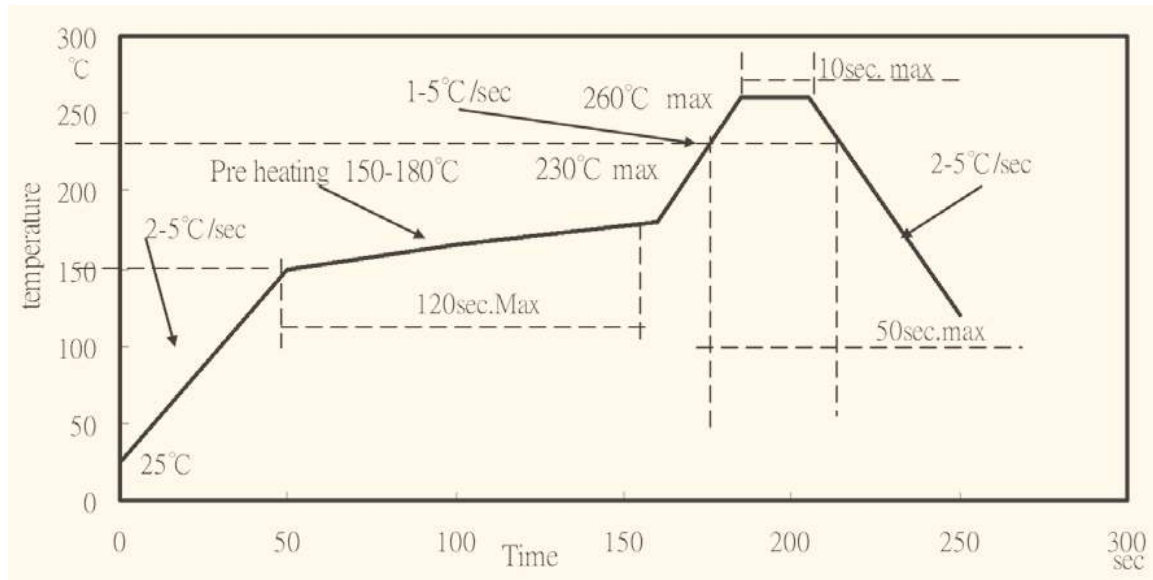

Soldering Iron

Basic Spec is ≤ 4 sec. when 260°C (+10°C \rightarrow -1 second). Power dissipation of Iron should be less than 15W. Surface temperature should be under 230°C

Rework

Rework should be completed within 4 second under 245°C

Packing

Reel

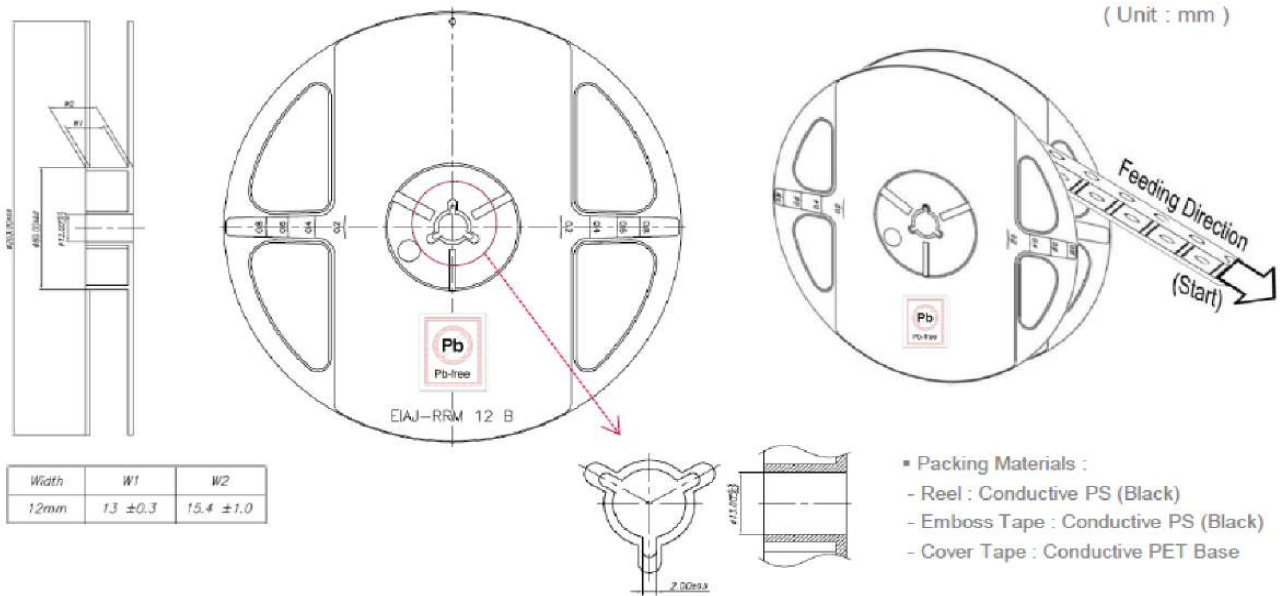

Tape

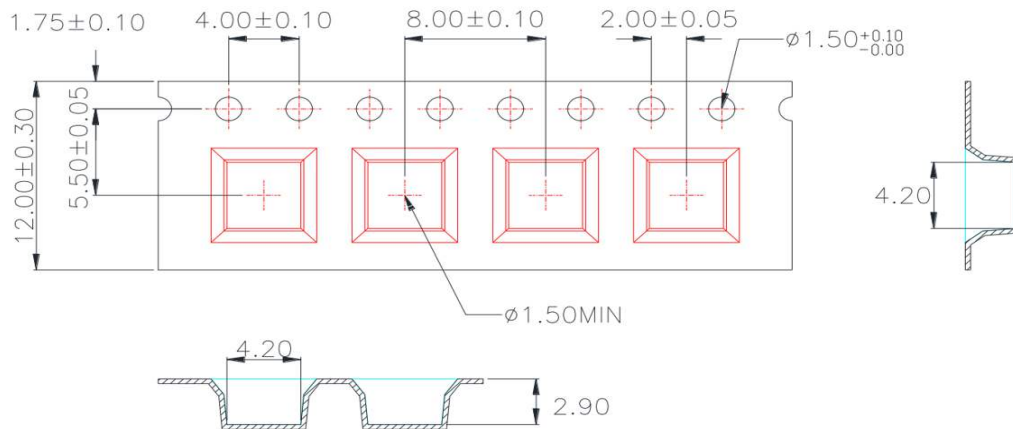

1. 10 sprocket hole pitch cumulative tolerance ± 0.20 .
2. Carrier camber is within 1 mm in 250 mm.
3. Material : Black Conductive Polystyrene Alloy.
4. All dimensions meet EIA-481-D requirements.
5. Thickness : 0.30 ± 0.05 mm.
6. Packing length per 22 " reel : 62.5 Meters(1:3).
7. Component load per 13" reel : 2500 pcs.

Notes:

1. Each Reel (minimum number of pieces is 100 and maximum is 1000 (125D) is packed in a moisture-proof bag along with 2 packs of desiccant and a humidity indicator card.
2. Part No., Lot No., quantity should be indicated on the label of the moisture-proof bag and the cardboard box.

Precautions

1. Recommendation for using LEDs

1.1 The lens of LEDs should not be exposed to dust or debris. Excessive dust and debris may cause a drastic decrease in the luminosity.

1.2 Avoid mechanical stress on LED lens.

1.3 Do not touch the LED lens surface. It would affect the optical performance of the LED due to the LED lens' damage.

1.4 Pick & place tools are recommended for the remove of LEDs from the factory tape & reel packaging

2. Pick & place nozzle

The pickup tool was recommended and shown as below

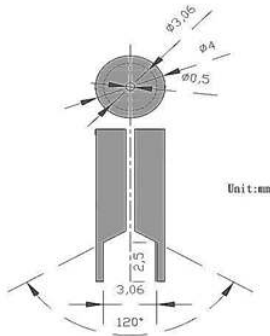

3. Lens handling

Please follow the guideline to pick LEDs

3.1 Use tweezers to pick LEDs

3.2 Do not touch the lens by using tweezers

3.3 Do not touch lens with fingers

3.4 Do not apply more than 4N of lens (400g) directly onto the lens

4. Lens cleaning

In the case which a small amount of dirt and dust particles remain on the lens surface, a suitable cleaning solution can be applied.

4.1 Try a gentle wiping with dust-free cloth

4.2 If needed, use dust-free cloth and isopropyl alcohol to gently clean the dirt from the lens surface.

4.3 Do not use other solvents as they may directly react with the LED assembly

4.4 Do not use ultrasonic cleaning which will damage the LEDs

Test Items and Results of Reliability

Test Item	Test Conditions	Duration/ Cycle	Number of Damage	Reference
Thermal Shock	-40°C 30min ↑↓5min 125°C 30min	100 cycles	0/22	AECQ101
High Temperature Storage	Ta=100°C	500 hrs	0/22	EIAJ ED-4701 200 201
Humidity Heat Storage	Ta=85°C RH=85%	500 hrs	0/22	EIAJ ED-4701 100 103
Low Temperature Storage	Ta=-40°C	500 hrs	0/22	EIAJ ED-4701 200 202
Life Test	Ta=25°C If=15mA	500 hrs	0/22	Tested with IN standard
High Humidity Heat Life Test	85°C RH=85% If=15mA	500 hrs	0/22	Tested with IN standard
High Temperature Life Test	Ta=85°C	500 hrs	0/22	Tested with IN standard
ESD(HBM)	8KV at 1.5kΩ;100pf	3 Times	0/22	MIL-STD-883

Criteria for Judging the Damage				
Item	Symbol	Condition	Criteria for Judgment	
			Min	Max
Forward Voltage	VF	If=15mA	LSL ×0.9	USL ×1.1
Reverse Current	IR	VR =5V	—	100μA
Luminous Intensity	Iv	If=500mA	LSL ×0.7	USL ×1.2

Notes:

1. USL: Upper specification level
2. LSL: Lower specification level

Revision History

Changes since last revision	Page	Version No.	Revision Date
Initial Release		1.0	10-08-2020

DISCLAIMER

INOLUX reserves the right to make changes without further notice to any products herein to improve reliability, function or design. INOLUX does not assume any liability arising out of the application or use of any product or circuit described herein; neither does it convey any license under its patent rights, nor the rights of others.

LIFE SUPPORT POLICY

INOLUX's products are not authorized for use as critical components in life support devices or systems without the express written approval of the President of INOLUX or INOLUX CORPORATION. As used herein:

1. Life support devices or systems are devices or systems which, (a) are intended for surgical implant into the body, or (b) support or sustain life, and (c) whose failure to perform when properly used in accordance with instructions for use provided in the labeling, can be reasonably expected to result in a significant injury of the user.
2. A critical component in any component of a life support device or system whose failure to perform can be reasonably expected to cause the failure of the life support device or system, or to affect its safety or effectiveness.