

FEATURES

- On-chip and remote temperature sensor**
- 0.25°C resolution/1°C accuracy on remote channel**
- 1°C resolution/3°C accuracy on local channel**
- Automatically cancels up to 3 kΩ (typ) of resistance in series with remote diode to allow noise filtering**
- Extended, switchable temperature measurement range**
0°C to +127°C (default) or -55°C to +150°C
- Pin- and register-compatible with the ADM1032**
- 2-wire SMBus serial interface with SMBus alert support**
- Two SMBus address versions available:**
 - ADT7461 SMBus address is 0x4C**
 - ADT7461-2 SMBus address is 0x4D**
- Programmable over/under temperature limits**
- Offset registers for system calibration**
- Up to two over temperature fail-safe THERM outputs**
- Small 8-lead SOIC or 8-lead MSOP packages**
- 170 μA operating current, 5.5 μA standby current**

APPLICATIONS

- Desktop and notebook computers**
- Industrial controllers**
- Smart batteries**
- Embedded systems**
- Instrumentation**

GENERAL DESCRIPTION

The ADT7461¹ is a dual-channel digital thermometer and under/over temperature alarm intended for use in PCs and thermal management systems. It is pin- and register-compatible with the ADM1032. The ADT7461 has three additional features: series resistance cancellation (where up to 3 kΩ (typical) of resistance in series with the temperature monitoring diode may be automatically cancelled from the temperature result, allowing noise filtering); configurable ALERT output; and an extended, switchable temperature measurement range. The ADT7461 can accurately measure the temperature of a remote thermal diode to ±1°C and the ambient temperature to ±3°C. The temperature measurement range defaults to 0°C to +127°C, compatible with the ADM1032, but can be switched to a wider measurement range of -55°C to +150°C. The ADT7461 communicates over a 2-wire serial interface compatible with system management bus (SMBus) standards. An ALERT output signals when the on-chip or remote temperature is out of range. The THERM output is a comparator output that allows on/off control of a cooling fan. The ALERT output can be reconfigured as a second THERM output, if required.

The SMBus address of the ADT7461 is 0x4C. An ADT7461-2 is also available, which uses SMBus Address 0x4D.

¹ Protected by U.S. Patents 5,195,827; 5,867,012; 5,982,221; 6,097,239; 6,133,753; 6,169,442; other patents pending.

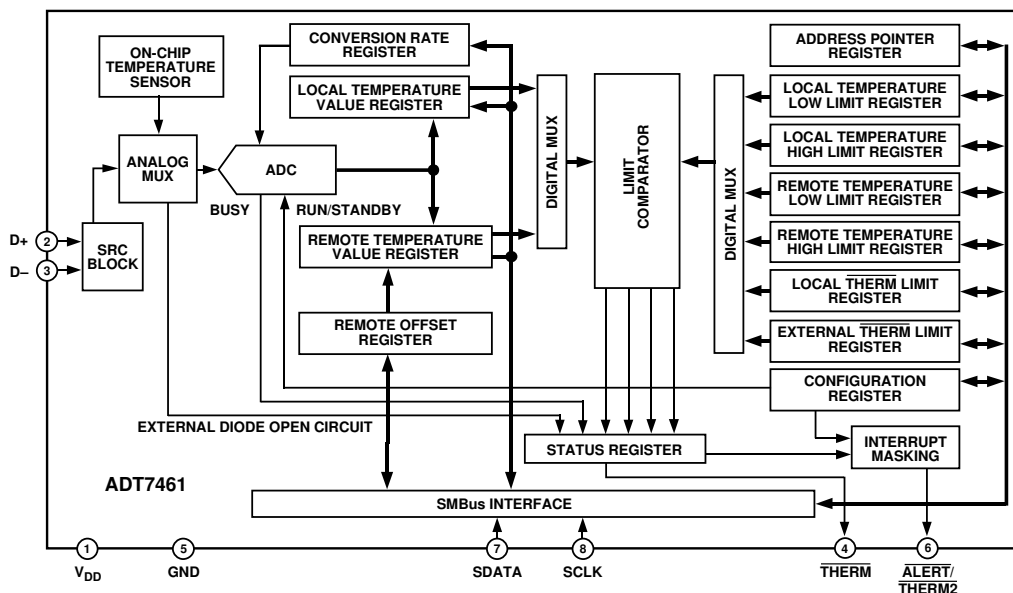

Figure 1. Functional Block Diagram

Rev. B

Information furnished by Analog Devices is believed to be accurate and reliable. However, no responsibility is assumed by Analog Devices for its use, nor for any infringements of patents or other rights of third parties that may result from its use. Specifications subject to change without notice. No license is granted by implication or otherwise under any patent or patent rights of Analog Devices. Trademarks and registered trademarks are the property of their respective owners.

TABLE OF CONTENTS

Specifications.....	3	ADT7461 Registers	11
SMBus Timing Specifications	4	Serial Bus Interface.....	14
Absolute Maximum Ratings.....	5	Addressing the Device	14
Thermal Characteristics	5	<u>ALERT</u> Output.....	16
ESD Caution.....	5	Low Power Standby Mode.....	16
Pin Configuration and Function Descriptions.....	6	Sensor Fault Detection	16
Typical Performance Characteristics	7	The ADT7461 Interrupt System.....	16
Functional Description	9	Application Information	18
Series Resistance Cancellation.....	9	Thermal Inertia and Self-Heating.....	18
Temperature Measurement Method	9	Layout Considerations.....	19
Temperature Measurement Results.....	10	Application Circuit.....	20
Temperature Measurement Range	10	Outline Dimensions	21
Temperature Data Format	10	Ordering Guide	22

REVISION HISTORY**7/05—Rev. A to Rev. B**

Changes to Features Section.....	1
Changes to Applications Section	1
Changes to General Description Section	1
Changes to Addressing the Device Section.....	14
Updated Outline Dimensions	21
Changes to the Ordering Guide.....	22

10/04—Rev. 0 to Rev. A

Change to SMBus Specifications	4
Changes to Figure 6 and Figure 10.....	7
Added Figure 9 and Figure 13.....	7
Changes to Temperature Measurement Section.....	10
Changes to Figure 19 and Figure 25.....	16
Changes to Serial Bus Interface Section	23

10/03—Revision 0: Initial Version

SPECIFICATIONS

$T_A = -40^{\circ}\text{C}$ to $+120^{\circ}\text{C}$, $V_{DD} = 3\text{ V}$ to 5.5 V , unless otherwise noted.

Table 1.

Parameter	Min	Typ	Max	Unit	Test Conditions
POWER SUPPLY					
Supply Voltage, V_{DD}	3.0	3.30	5.5	V	
Average Operating Supply Current, I_{DD}		170	215	μA	0.0625 conversions/sec rate ¹
		5.5	10	μA	Standby mode, $-40^{\circ}\text{C} \leq T_A \leq +85^{\circ}\text{C}$
		5.5	20	μA	Standby mode, $+85^{\circ}\text{C} \leq T_A \leq +120^{\circ}\text{C}$
Undervoltage Lockout Threshold	2.2	2.55	2.8	V	V_{DD} input, disables ADC, rising edge
Power-On-Reset Threshold	1		2.5	V	
TEMPERATURE-TO-DIGITAL CONVERTER					
Local Sensor Accuracy		± 1	± 3	$^{\circ}\text{C}$	$-40^{\circ}\text{C} \leq T_A \leq +100^{\circ}\text{C}$, $3\text{ V} \leq V_{DD} \leq 3.6\text{ V}$
Resolution		1		$^{\circ}\text{C}$	
Remote Diode Sensor Accuracy			± 1	$^{\circ}\text{C}$	$+60^{\circ}\text{C} \leq T_A \leq +100^{\circ}\text{C}$, $-55^{\circ}\text{C} \leq T_D^2 \leq +150^{\circ}\text{C}$, $3\text{ V} \leq V_{DD} \leq 3.6\text{ V}$
			± 3	$^{\circ}\text{C}$	$-40^{\circ}\text{C} \leq T_A \leq +120^{\circ}\text{C}$, $-55^{\circ}\text{C} \leq T_D^2 \leq +150^{\circ}\text{C}$, $3\text{ V} \leq V_{DD} \leq 5.5\text{ V}$
Resolution		0.25		$^{\circ}\text{C}$	
Remote Sensor Source Current		96		μA	High level ³
		36		μA	Middle level ³
		6		μA	Low level ³
Conversion Time	32.13		114.6	ms	From stop bit to conversion complete (both channels), one-shot mode with averaging switched on
	3.2		12.56	ms	One-shot mode with averaging off (that is, conversion rate = 16, 32, or 64 conversions per second)
Maximum Series Resistance Cancelled		3		k Ω	Resistance split evenly on both the D+ and D- inputs
OPEN-DRAIN DIGITAL OUTPUTS (THERM, ALERT/THERM2)					
Output Low Voltage, V_{OL}			0.4	V	$I_{OUT} = -6.0\text{ mA}$ ³
High Level Output Leakage Current, I_{OH}		0.1	1	μA	$V_{OUT} = V_{DD}$ ³
ALERT Output Low Sink Current	1			mA	ALERT forced to 0.4 V
SMBus INTERFACE^{3, 4}					
Logic Input High Voltage, V_{IH} SCLK, SDATA	2.1			V	$3\text{ V} \leq V_{DD} \leq 3.6\text{ V}$
Logic Input Low Voltage, V_{IL} SCLK, SDATA			0.8	V	$3\text{ V} \leq V_{DD} \leq 3.6\text{ V}$
Hysteresis		500		mV	
SMBus Output Low Sink Current	6			mA	SDATA forced to 0.6 V
Logic Input Current, I_{IH} , I_{IL}	-1		+1	μA	
SMBus Input Capacitance, SCLK, SDATA		5		pF	
SMBus Clock Frequency			400	kHz	
SMBus Timeout ⁵		25	64	ms	User programmable
SCLK Falling Edge to SDATA Valid Time			1	μs	Master clocking in data

¹ See Table 8 for information on other conversion rates.

² Guaranteed by characterization, but not production tested.

³ Guaranteed by design, but not production tested.

⁴ See the SMBUS Timing Specifications section for more information.

⁵ Disabled by default; see the Serial Bus Interface section for details on enabling it.

SMBus TIMING SPECIFICATIONS

Table 2. SMBus Timing Specifications¹

Parameter	Limit at T _{MIN} and T _{MAX}	Unit	Description
f _{SCLK}	400	kHz max	
t _{LOW}	1.3	μs min	Clock low period, between 10% points
t _{HIGH}	0.6	μs min	Clock high period, between 90% points
t _R	300	ns max	Clock/data rise time
t _F	300	ns max	Clock/data fall time
t _{SU;STA}	600	ns min	Start condition setup time
t _{HD;STA} ²	600	ns min	Start condition hold time
t _{SU;DAT} ³	100	ns min	Data setup time
t _{HD;DAT}	300	ns min	Data hold time
t _{SU;STO} ⁴	600	ns min	Stop condition setup time
t _{BUF}	1.3	μs min	Bus free time between stop and start conditions

¹ Guaranteed by design, but not production tested.

² Time from 10% of SDATA to 90% of SCLK.

³ Time for 10% or 90% of SDATA to 10% of SCLK.

⁴ Time for 90% of SCLK to 10% of SDATA.

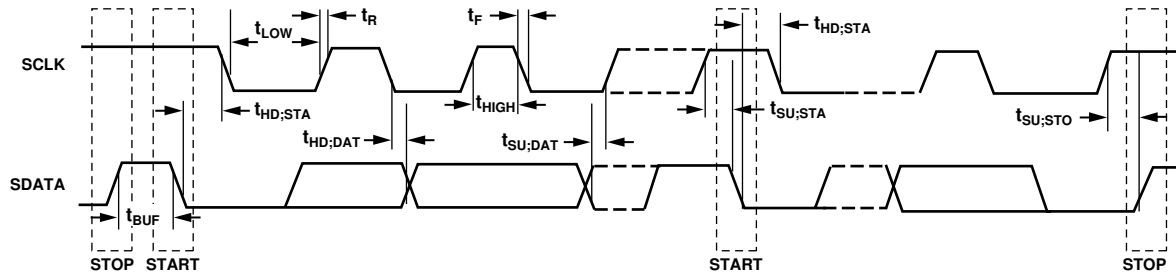

Figure 2. Serial Bus Timing

04116-0-001

ABSOLUTE MAXIMUM RATINGS

Table 3.

Parameter	Rating
Positive Supply Voltage (V_{DD}) to GND	-0.3 V, +5.5 V
D+	-0.3 V to $V_{DD} + 0.3$ V
D- to GND	-0.3 V to +0.6 V
SCLK, SDATA, $\overline{\text{ALERT}}$	-0.3 V to +5.5 V
$\overline{\text{THERM}}$	-0.3 V to $V_{DD} + 0.3$ V
Input Current, SDATA, $\overline{\text{THERM}}$	-1 mA, +50 mA
Input Current, D-	± 1 mA
ESD Rating, All Pins (Human Body Model)	2000 V
Maximum Junction Temperature (T_J max)	150°C
Storage Temperature Range	-65°C to +150°C
IR Reflow Peak Temperature	220°C
Pb-Free Parts Only	260°C ($\pm 0.5^\circ\text{C}$)
Lead Temperature (Soldering 10 sec)	300°C

THERMAL CHARACTERISTICS

8-lead SOIC package

$$\theta_{JA} = 121^\circ\text{C/W}$$

8-lead MSOP package

$$\theta_{JA} = 142^\circ\text{C/W}$$

Stresses above those listed under Absolute Maximum Ratings may cause permanent damage to the device. This is a stress rating only; functional operation of the device at these or any other conditions above those indicated in the operational section of this specification is not implied. Exposure to absolute maximum rating conditions for extended periods may affect device reliability.

ESD CAUTION

ESD (electrostatic discharge) sensitive device. Electrostatic charges as high as 4000 V readily accumulate on the human body and test equipment and can discharge without detection. Although this product features proprietary ESD protection circuitry, permanent damage may occur on devices subjected to high energy electrostatic discharges. Therefore, proper ESD precautions are recommended to avoid performance degradation or loss of functionality.



ADT7461

PIN CONFIGURATION AND FUNCTION DESCRIPTIONS

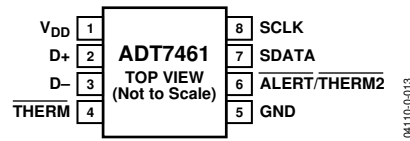

Figure 3. Pin Configuration

Table 4. Pin Function Descriptions

Pin No.	Mnemonic	Description
1	V _{DD}	Positive Supply, 3 V to 5.5 V.
2	D+	Positive Connection to Remote Temperature Sensor.
3	D-	Negative Connection to Remote Temperature Sensor.
4	$\overline{\text{THERM}}$	Open-drain output that can be used to turn a fan on/off or throttle a CPU clock in the event of an overtemperature condition. Requires pull-up to V _{DD} .
5	GND	Supply Ground Connection.
6	$\overline{\text{ALERT/THERM2}}$	Open-Drain Logic Output Used as Interrupt or SMBus Alert. This may also be configured as a second $\overline{\text{THERM}}$ output. Requires pull-up resistor.
7	SDATA	Logic Input/Output, SMBus Serial Data. Open-Drain Output. Requires pull-up resistor.
8	SCLK	Logic Input, SMBus Serial Clock. Requires pull-up resistor.

TYPICAL PERFORMANCE CHARACTERISTICS

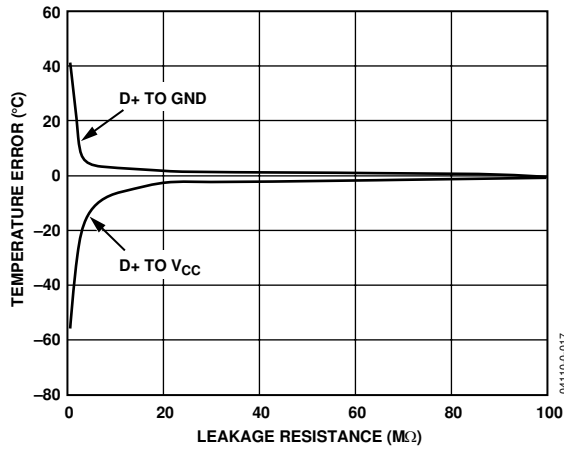

Figure 4. Temperature Error vs. Leakage Resistance

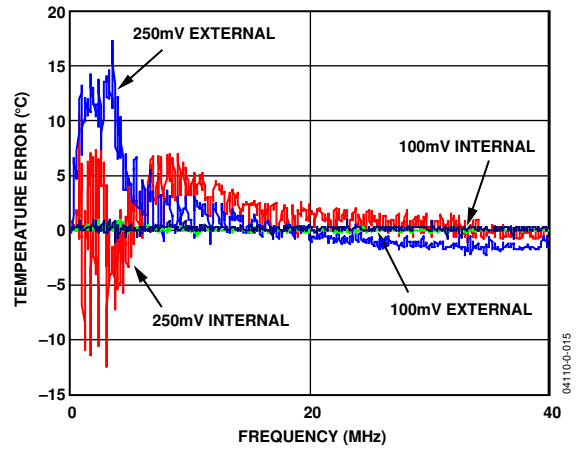

Figure 7. Temperature Error vs. Power Supply Noise Frequency

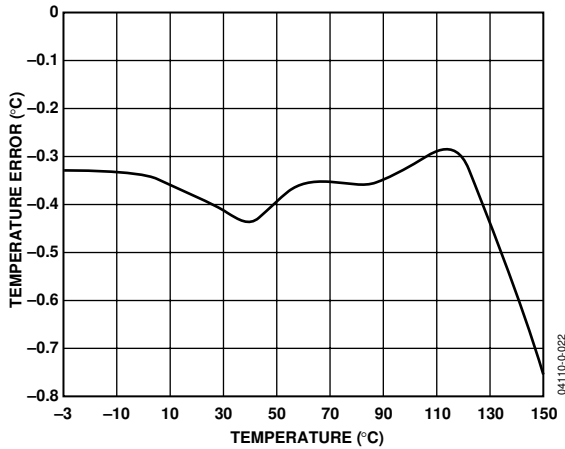

Figure 5. Temperature Error vs. Actual Temperature Using 2N3906

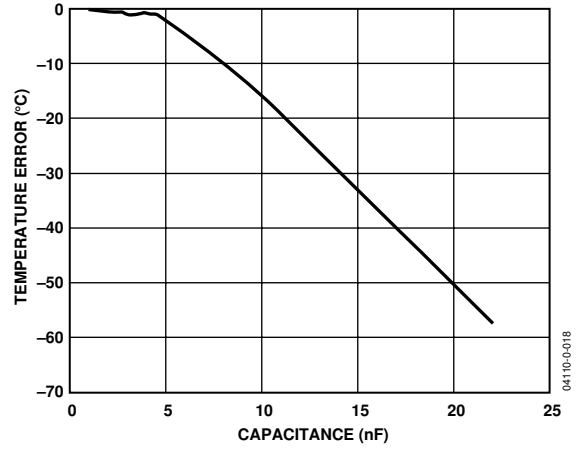

Figure 8. Temperature Error vs. Capacitance Between D+ and D-

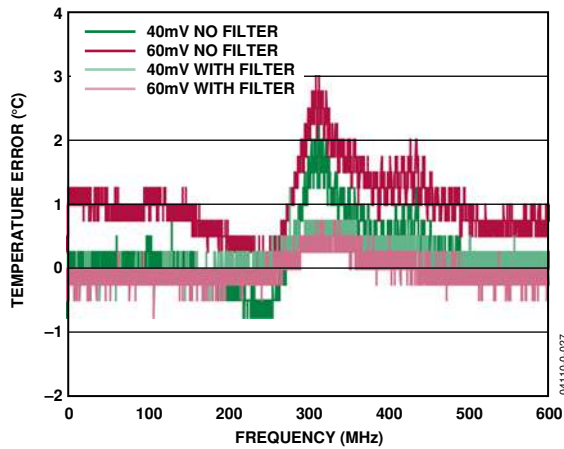

Figure 6. Temperature Error vs. Differential Mode Noise Frequency (With and Without R-C-R Filter of 100Ω–2.2 nF–100Ω)

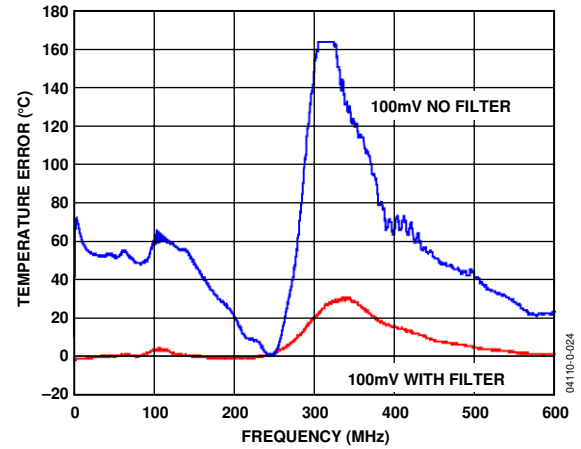

Figure 9. Temperature Error vs. 100 mV Differential Mode Noise Frequency (With and Without R-C-R Filter of 100Ω–2.2 nF–100Ω)

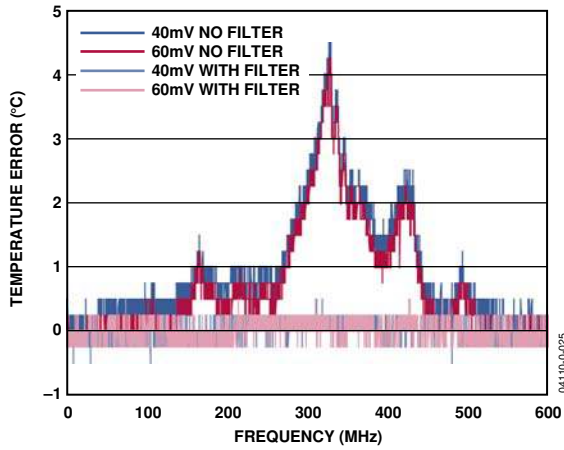

Figure 10. Temperature Error vs. Common-Mode Noise Frequency (With and Without R-C-R Filter of 100 Ω–2.2 nF–100 Ω)

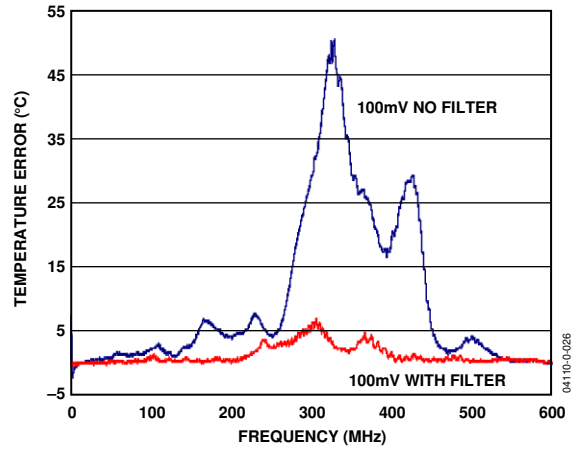

Figure 13. Temperature Error vs. 100 mV Common-Mode Noise Frequency (With and Without R-C-R Filter of 100 Ω–2.2 nF–100 Ω)

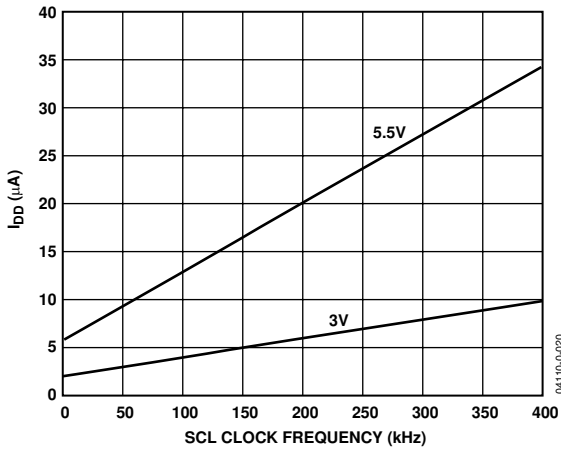

Figure 11. Standby Supply Current vs. Clock Frequency

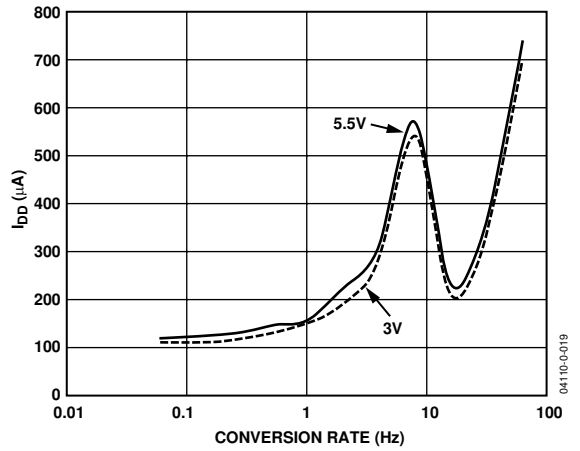

Figure 14. Operating Supply Current vs. Conversion Rate

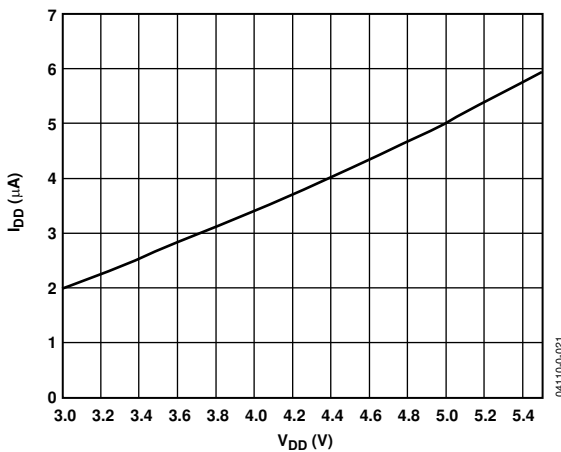

Figure 12. Standby Current vs. Supply Voltage

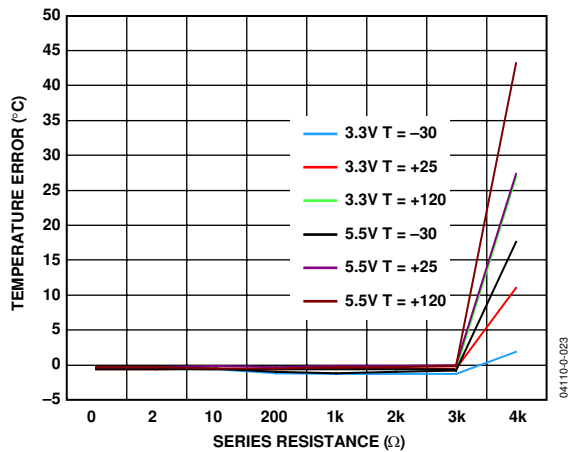

Figure 15. Temperature Error vs. Series Resistance

FUNCTIONAL DESCRIPTION

The ADT7461 is a local and remote temperature sensor and over/under temperature alarm, with the added ability to automatically cancel the effect of 3 k Ω (typical) of resistance in series with the temperature monitoring diode. When the ADT7461 is operating normally, the on-board ADC operates in a free-running mode. The analog input multiplexer alternately selects either the on-chip temperature sensor to measure its local temperature or the remote temperature sensor. The ADC digitizes these signals and the results are stored in the local and remote temperature value registers.

The local and remote measurement results are compared with the corresponding high, low, and THERM temperature limits, stored in eight on-chip registers. Out-of-limit comparisons generate flags that are stored in the status register. A result that exceeds the high temperature limit, the low temperature limit, or an external diode fault causes the ALERT output to assert low. Exceeding THERM temperature limits causes the THERM output to assert low. The ALERT output can be reprogrammed as a second THERM output.

The limit registers can be programmed and the device controlled and configured via the serial SMBus. The contents of any register can also be read back via the SMBus.

Control and configuration functions consist of switching the device between normal operation and standby mode, selecting the temperature measurement scale, masking or enabling the ALERT output, switching Pin 6 between ALERT and THERM2, and selecting the conversion rate.

SERIES RESISTANCE CANCELLATION

Parasitic resistance to the D+ and D- inputs to the ADT7461, seen in series with the remote diode, is caused by a variety of factors, including PCB track resistance and track length. This series resistance appears as a temperature offset in the remote sensor's temperature measurement. This error typically causes a 0.5°C offset per ohm of parasitic resistance in series with the remote diode.

The ADT7461 automatically cancels out the effect of this series resistance on the temperature reading, giving a more accurate result, without the need for user characterization of this resistance. The ADT7461 is designed to automatically cancel typically up to 3 k Ω of resistance. By using an advanced temperature measurement method, this is transparent to the user. This feature allows resistances to be added to the sensor path to produce a filter, allowing the part to be used in noisy environments. See the Noise Filtering section for more details.

TEMPERATURE MEASUREMENT METHOD

A simple method of measuring temperature is to exploit the negative temperature coefficient of a diode by measuring the base-emitter voltage (V_{BE}) of a transistor operated at constant current. However, this technique requires calibration to null out the effect of the absolute value of V_{BE} , which varies from device to device.

The technique used in the ADT7461 is to measure the change in V_{BE} when the device is operated at three different currents. Previous devices have used only two operating currents, but it is the use of a third current that allows automatic cancellation of resistances in series with the external temperature sensor.

Figure 16 shows the input signal conditioning used to measure the output of an external temperature sensor. This figure shows the external sensor as a substrate transistor, but it could equally be a discrete transistor. If a discrete transistor is used, the collector will not be grounded and should be linked to the base. To prevent ground noise interfering with the measurement, the more negative terminal of the sensor is not referenced to ground, but is biased above ground by an internal diode at the D- input. C1 may be added as a noise filter (a recommended maximum value of 1,000 pF). However, a better option in noisy environments is to add a filter, as described in the Noise Filtering section. See the Layout Considerations section for more information on C1.

To measure ΔV_{BE} , the operating current through the sensor is switched among three related currents. Figure 16 shows $N1 \times I$ and $N2 \times I$ as different multiples of the current, I . The currents through the temperature diode are switched between I and $N1 \times I$, giving ΔV_{BE1} , and then between I and $N2 \times I$, giving ΔV_{BE2} . The temperature may then be calculated using the two ΔV_{BE} measurements. This method can also be shown to cancel the effect of any series resistance on the temperature measurement.

The resulting ΔV_{BE} waveforms are passed through a 65 kHz low-pass filter to remove noise and then to a chopper-stabilized amplifier. This amplifies and rectifies the waveform to produce a dc voltage proportional to ΔV_{BE} . The ADC digitizes this voltage and a temperature measurement is produced. To reduce the effects of noise, digital filtering is performed by averaging the results of 16 measurement cycles for low conversion rates. At rates of 16, 32, and 64 conversions per second, no digital averaging takes place.

Signal conditioning and measurement of the internal temperature sensor is performed in the same manner.

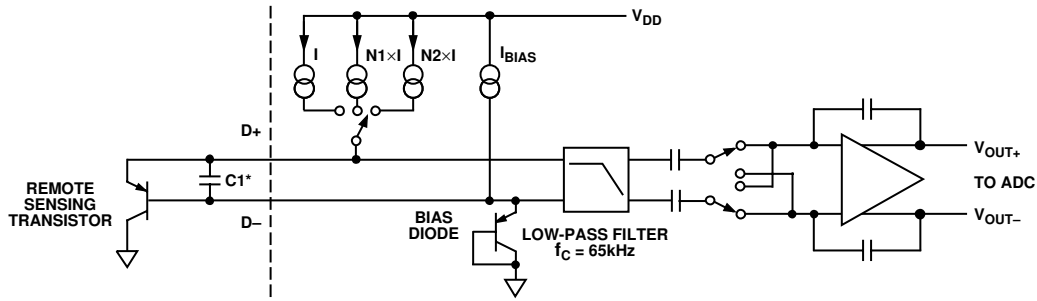

*CAPACITOR C1 IS OPTIONAL. IT SHOULD ONLY BE USED IN NOISY ENVIRONMENTS.

Figure 16. Input Signal Conditioning

04110-0-002

TEMPERATURE MEASUREMENT RESULTS

The results of the local and remote temperature measurements are stored in the local and remote temperature value registers and are compared with limits programmed into the local and remote high and low limit registers.

The local temperature value is in Register 0x00 and has a resolution of 1°C. The external temperature value is stored in two registers, with the upper byte in Register 0x01 and the lower byte in Register 0x10. Only the two MSBs in the external temperature low byte are used. This gives the external temperature measurement a resolution of 0.25°C. Table 5 shows the data format for the external temperature low byte.

Table 5. Extended Temperature Resolution (Remote Temperature Low Byte)

Extended Resolution	Remote Temperature Low Byte
0.00°C	0 000 0000
0.25°C	0 100 0000
0.50°C	1 000 0000
0.75°C	1 100 0000

When reading the full external temperature value, both the high and low byte, the two registers should be read in succession. Reading one register does not lock the other, so both should be read before the next conversion finishes. In practice, there is more than enough time to read both registers, as transactions over the SMBus are significantly faster than a conversion time.

TEMPERATURE MEASUREMENT RANGE

The temperature measurement range for both internal and external measurements is, by default, 0°C to +127°C. However, the ADT7461 can be operated using an extended temperature range. It can measure the full temperature range of an external diode, from -55°C to +150°C. The user can switch between these two temperature ranges by setting or clearing Bit 2 in the configuration register. A valid result is available in the next measurement cycle after changing the temperature range.

In extended temperature mode, the upper and lower temperature that can be measured by the ADT7461 is limited by the remote diode selection. The temperature registers themselves can have values from -64°C to +191°C. However, most temperature sensing diodes have a maximum temperature range of -55°C to +150°C.

Above 150°C, they may lose their semiconductor characteristics and approximate conductors instead. This results in a diode short. In this case, a read of the temperature result register gives the last good temperature measurement. The user should be aware that the temperature measurement on the external channel may not be accurate for temperatures that are outside the operating range of the remote sensor.

While both local and remote temperature measurements can be made while the part is in extended temperature mode, the ADT7461 itself should not be exposed to temperatures greater than those specified in the Absolute Maximum Ratings section. Also, the device is guaranteed to operate only as specified at ambient temperatures from -40°C to +120°C.

TEMPERATURE DATA FORMAT

The ADT7461 has two temperature data formats. When the temperature measurement range is from 0°C to +127°C (default), the temperature data format for both internal and external temperature results is binary. When the measurement range is in extended mode, an offset binary data format is used for both internal and external results. Temperature values in the offset binary data format are offset by 64°C. Examples of temperatures in both data formats are shown in Table 6.

Table 6. Temperature Data Format (Local and Remote Temperature High Byte)

Temperature	Binary	Offset Binary ¹
-55°C	0 000 0000 ²	0 000 1001
0°C	0 000 0000	0 100 0000
+1°C	0 000 0001	0 100 0001
+10°C	0 000 1010	0 100 1010
+25°C	0 001 1001	0 101 1001
+50°C	0 011 0010	0 111 0010
+75°C	0 100 1011	1 000 1011
+100°C	0 110 0100	1 010 0100
+125°C	0 111 1101	1 011 1101
+127°C	0 111 1111	1 011 1111
+150°C	0 111 1111 ³	1 101 0110

¹ Offset binary scale temperature values are offset by 64°C.

² Binary scale temperature measurement returns 0°C for all temperatures < 0°C.

³ Binary scale temperature measurement returns 127°C for all temperatures > 127°C.

The user can switch between measurement ranges at any time. Switching the range also switches the data format. The next temperature result following the switching is reported back to the register in the new format. However, the contents of the limit registers are not changed. The user must ensure that the limit registers are reprogrammed, as necessary, when the data format changes. See the Limit Registers section for more information.

ADT7461 REGISTERS

The ADT7461 contains a total of 22 8-bit registers. These registers are used to store the results of remote and local temperature measurements and high and low temperature limits and to configure and control the device. A description of these registers follows. Additional details are provided in Table 7 to Table 11.

Address Pointer Register

The address pointer register does not have or require an address, as the first byte of every write operation is automatically written to this register. The data in this first byte always contains the address of another register on the ADT7461, which is stored in the address pointer register. This register address is written to by the second byte of a write operation or is used for a subsequent read operation.

The power-on default value of the address pointer register is 0x00. Therefore, if a read operation is performed immediately after power-on, without first writing to the address pointer, the value of the local temperature is returned, since its register address is 0x00.

Temperature Value Registers

The ADT7461 has three registers to store the results of local and remote temperature measurements. These registers can only be written to by the ADC and can be read by the user over the SMBus. The local temperature value register is at Address 0x00.

The external temperature value high byte register is at Address 0x01, with the low byte register at Address 0x10. The power-on default for all three registers is 0x00.

Configuration Register

The configuration register is Address 0x03 at read and Address 0x09 at write. Its power-on default is 0x00. Only four bits of the configuration register are used. Bits 0, 1, 3, and 4 are reserved and should not be written to by the user.

Bit 7 of the configuration register is used to mask the $\overline{\text{ALERT}}$ output. If Bit 7 is 0, the $\overline{\text{ALERT}}$ output is enabled. This is the power-on default. If Bit 7 is set to 1, the $\overline{\text{ALERT}}$ output is disabled. This only applies if Pin 6 is configured as $\overline{\text{ALERT}}$. If Pin 6 is configured as $\overline{\text{THERM2}}$, the value of Bit 7 has no effect.

If Bit 6 is set to 0 (the power-on default), the device is in operating mode with the ADC converting. If Bit 6 is set to 1, the device is in standby mode and the ADC does not convert. The SMBus does, however, remain active in standby mode, so values can be read from or written to the ADT7461 via the SMBus in this mode. The $\overline{\text{ALERT}}$ and $\overline{\text{THERM}}$ outputs are also active in standby mode. Changes made to the registers in standby mode that affect the $\overline{\text{THERM}}$ or $\overline{\text{ALERT}}$ outputs cause these signals to be updated.

Bit 5 determines the configuration of Pin 6 on the ADT7461. If Bit 5 is 0 (default), then Pin 6 is configured as an $\overline{\text{ALERT}}$ output. If Bit 5 is 1, then Pin 6 is configured as a $\overline{\text{THERM2}}$ output. Bit 7, the $\overline{\text{ALERT}}$ mask bit, is only active when Pin 6 is configured as an $\overline{\text{ALERT}}$ output. If Pin 6 is set up as a $\overline{\text{THERM2}}$ output, then Bit 7 has no effect.

Bit 2 sets the temperature measurement range. If Bit 2 is 0 (default), the temperature measurement range is set between 0°C to +127°C. Setting Bit 2 to 1 means that the measurement range is set to the extended temperature range.

Table 7. Configuration Register Bit Assignments

Bit	Name	Function	Power-On Default
7	MASK1	0 = $\overline{\text{ALERT}}$ enabled 1 = $\overline{\text{ALERT}}$ masked	0
6	RUN/STOP	0 = Run 1 = Standby	0
5	$\overline{\text{ALERT}}/\overline{\text{THERM2}}$	0 = $\overline{\text{ALERT}}$ 1 = $\overline{\text{THERM2}}$	0
4, 3	Reserved		0
2	Temperature Range Select	0 = 0°C to 127°C 1 = Extended range	0
1, 0	Reserved		0

Conversion Rate Register

The conversion rate register is Address 0x04 at read and Address 0x0A at write. The lowest four bits of this register are used to program the conversion rate by dividing the internal oscillator clock by 1, 2, 4, 8, 16, 32, 64, 128, 256, 512, or 1024 to give conversion times from 15.5 ms (Code 0x0A) to 16 seconds (Code 0x00). For example, a conversion rate of 8 conversions per second means that beginning at 125 ms intervals, the device performs a conversion on the internal and external temperature channels.

This register can be written to and read back over the SMBus. The higher four bits of this register are unused and must be set to 0. The default value of this register is 0x08, giving a rate of 16 conversions per second. Use of slower conversion times greatly reduces the device power consumption, as shown in Table 8.

Table 8. Conversion Rate Register Codes

Code	Conversion/Second	Average Supply Current $\mu\text{A Typ}$ at $V_{DD} = 5.5\text{ V}$
0x00	0.0625	121.33
0x01	0.125	128.54
0x02	0.25	131.59
0x03	0.5	146.15
0x04	1	169.14
0x05	2	233.12
0x06	4	347.42
0x07	8	638.07
0x08	16	252.44
0x09	32	417.58
0x0A	64	816.87
0x0B to 0xFF	Reserved	

Limit Registers

The ADT7461 has eight limit registers: high, low, and $\overline{\text{THERM}}$ temperature limits for both local and remote temperature measurements. The remote temperature high and low limits span two registers each to contain an upper and lower byte for each limit. There is also a $\overline{\text{THERM}}$ hysteresis register. All limit registers can be written to and read back over the SMBus. See Table 12 for address details of the limit registers and their power-on default values.

When Pin 6 is configured as an $\overline{\text{ALERT}}$ output, the high limit registers perform a $>$ comparison while the low limit registers perform a \leq comparison. For example, if the high limit register is programmed with 80°C , then measuring 81°C results in an out-of-limit condition, setting a flag in the status register. If the low limit register is programmed with 0°C , measuring 0°C or lower results in an out-of-limit condition.

Exceeding either the local or remote $\overline{\text{THERM}}$ limit asserts $\overline{\text{THERM}}$ low. When Pin 6 is configured as $\overline{\text{THERM2}}$, exceeding either the local or remote high limit asserts $\overline{\text{THERM2}}$ low. A default hysteresis value of 10°C is provided that applies to both $\overline{\text{THERM}}$ channels. This hysteresis value may be reprogrammed to any value after power-up (Register Address 0x21).

It is important to remember that the temperature limits data format is the same as the temperature measurement data format. So, if the temperature measurement uses default binary, the temperature limits also use the binary scale. If the temperature measurement scale is switched, however, the temperature limits do not switch automatically. The user must reprogram the limit registers to the desired value in the correct data format. For example, if the remote low limit is set at 10°C and the default binary scale is being used, the limit register value should be 0000 1010b. If the scale is switched to offset binary, the value in the low temperature limit register should be reprogrammed to be 0100 1010b.

Status Register

The status register is a read-only register at Address 0x02. It contains status information for the ADT7461.

Bit 7 of the status register indicates the ADC is busy converting when it is high. The other bits in this register flag the out-of-limit temperature measurements (Bits 6 to 3 and Bits 1 to 0) and the remote sensor open circuit (Bit 2).

If Pin 6 is configured as an $\overline{\text{ALERT}}$ output, the following applies. If the local temperature measurement exceeds its limits, Bit 6 (high limit) or Bit 5 (low limit) of the status register asserts to flag this condition. If the remote temperature measurement exceeds its limits, then Bit 4 (high limit) or Bit 3 (low limit) asserts. Bit 2 asserts to flag an open-circuit condition on the remote sensor. These five flags are NOR'd together so if any of them is high, the $\overline{\text{ALERT}}$ interrupt latch is set and the $\overline{\text{ALERT}}$ output goes low.

Reading the status register clears the five flags, Bits 6 to 2, provided the error conditions causing the flags to be set have gone away. A flag bit can be reset only if the corresponding value register contains an in-limit measurement or if the sensor is good.

The $\overline{\text{ALERT}}$ interrupt latch is not reset by reading the status register. It resets when the $\overline{\text{ALERT}}$ output has been serviced by the master reading the device address, provided the error condition has gone away and the status register flag bits are reset.

When Flag 1 and/or Flag 0 are set, the $\overline{\text{THERM}}$ output goes low to indicate the temperature measurements are outside the programmed limits. The $\overline{\text{THERM}}$ output does not need to be reset, unlike the $\overline{\text{ALERT}}$ output. Once the measurements are within the limits, the corresponding status register bits are reset automatically and the $\overline{\text{THERM}}$ output goes high. The user may add hysteresis by programming Register 0x21. The $\overline{\text{THERM}}$ output is reset only when the temperature falls to limit value minus hysteresis value.

When Pin 6 is configured as $\overline{\text{THERM2}}$, only the high temperature limits are relevant. If Flag 6 and/or Flag 4 are set, the $\overline{\text{THERM2}}$ output goes low to indicate the temperature measurements are outside the programmed limits. Flag 5 and Flag 3 have no effect on $\overline{\text{THERM2}}$. The behavior of $\overline{\text{THERM2}}$ is otherwise the same as $\overline{\text{THERM}}$.

Table 9. Status Register Bit Assignments

Bit	Name	Function
7	BUSY	1 when ADC is converting
6	LHIGH ¹	1 when local high temperature limit is tripped
5	LLOW ¹	1 when local low temperature limit is tripped
4	RHIGH ¹	1 when remote high temperature limit is tripped
3	RLOW ¹	1 when remote low temperature limit is tripped
2	OPEN ¹	1 when remote sensor is an open circuit
1	RTHRM	1 when remote $\overline{\text{THERM}}$ limit is tripped
0	LTHRM	1 when local $\overline{\text{THERM}}$ limit is tripped

¹ These flags stay high until the status register is read or they are reset by POR.

Offset Register

Offset errors may be introduced into the remote temperature measurement by clock noise or by the thermal diode being located away from the hot spot. To achieve the specified accuracy on this channel, these offsets must be removed.

The offset value is stored as a 10-bit, twos complement value in Registers 0x11 (high byte) and 0x12 (low byte, left justified). Only the upper 2 bits of Register 0x12 are used. The MSB of Register 0x11 is the sign bit. The minimum offset that can be programmed is -128°C , and the maximum is $+127.75^{\circ}\text{C}$. The value in the offset register is added to the measured value of the remote temperature.

The offset register powers up with a default value of 0°C and has no effect unless the user writes a different value to it.

Table 10. Sample Offset Register Codes

Offset Value	0x11	0x12
-128°C	1000 0000	00 00 0000
-4°C	1111 1100	00 00 0000
-1°C	1111 1111	00 000000
-0.25°C	1111 1111	10 00 0000
0°C	0000 0000	00 00 0000
$+0.25^{\circ}\text{C}$	0000 0000	01 00 0000
$+1^{\circ}\text{C}$	0000 0001	00 00 0000
$+4^{\circ}\text{C}$	0000 0100	00 00 0000
$+127.75^{\circ}\text{C}$	0111 1111	11 00 0000

One-Shot Register

The one-shot register is used to initiate a conversion and comparison cycle when the ADT7461 is in standby mode, after which the device returns to standby. Writing to the one-shot register address (0x0F) causes the ADT7461 to perform a conversion and comparison on both the internal and the external temperature channels. This is not a data register as such; the write operation to Address 0x0F causes the one-shot conversion. The data written to this address is irrelevant and is not stored.

Consecutive ALERT Register

The value written to this register determines how many out-of-limit measurements must occur before an ALERT is generated. The default value is that one out-of-limit measurement generates an ALERT. The maximum value that can be chosen is 4. The purpose of this register is to allow the user to perform some filtering of the output. This is particularly useful at the fastest three conversion rates, where no averaging takes place. This register is at Address 0x22.

Table 11. Consecutive ALERT Register Bit

Register Value ^{1, 2}	Number of Out-of-Limit Measurements Required
yxxx 000x	1
yxxx 001x	2
yxxx 011x	3
yxxx 111x	4

¹ x = don't care bit.

² y = SMBus timeout bit; default = 0. See the Serial Bus Interface section.

Table 12. List of Registers

Read Address (Hex)	Write Address (Hex)	Name	Power-On Default
Not applicable	Not applicable	Address Pointer	Undefined
0x00	Not applicable	Local Temperature Value	0000 0000 (0x00)
0x01	Not applicable	External Temperature Value High Byte	0000 0000 (0x00)
0x02	Not applicable	Status	Undefined
0x03	0x09	Configuration	0000 0000 (0x00)
0x04	0x0A	Conversion Rate	0000 1000 (0x08)
0x05	0x0B	Local Temperature High Limit	0101 0101 (0x55) (85°C)
0x06	0x0C	Local Temperature Low Limit	0000 0000 (0x00) (0°C)
0x07	0x0D	External Temperature High Limit High Byte	0101 0101 (0x55) (85°C)
0x08	0x0E	External Temperature Low Limit High Byte	0000 0000 (0x00) (0°C)
Not applicable	0x0F ¹	One-Shot	
0x10	Not applicable	External Temperature Value Low Byte	0000 0000
0x11	0x11	External Temperature Offset High Byte	0000 0000
0x12	0x12	External Temperature Offset Low Byte	0000 0000
0x13	0x13	External Temperature High Limit Low Byte	0000 0000
0x14	0x14	External Temperature Low Limit Low Byte	0000 0000
0x19	0x19	External THERM Limit	0110 1100 (0x55) (85°C)
0x20	0x20	Local THERM Limit	0101 0101 (0x55) (85°C)
0x21	0x21	THERM Hysteresis	0000 1010 (0x0A) (10°C)
0x22	0x22	Consecutive ALERT	0000 0001 (0x01)
0xFE	Not applicable	Manufacturer ID	0100 0001 (0x41)
0xFF	Not applicable	Die Revision Code	0101 0001 (0x51)

¹ Writing to Address 0x0F causes the ADT7461 to perform a single measurement. It is not a data register; therefore, data written to it is irrelevant.

SERIAL BUS INTERFACE

Control of the ADT7461 is carried out via the serial bus. The ADT7461 is connected to this bus as a slave device, under the control of a master device.

After a conversion sequence completes, there should be no SMBus transactions to the ADT7461 for at least one conversion time, to allow the next conversion to complete. The conversion time depends on the value programmed in the conversion rate register.

The ADT7461 has an SMBus timeout feature. When this is enabled, the SMBus times out typically after 25 ms of inactivity. However, this feature is not enabled by default. Bit 7 of the consecutive alert register (Address = 0x22) should be set to enable it.

Consult the SMBus 1.1 specification for more information (www.smbus.org).

ADDRESSING THE DEVICE

In general, every SMBus device has a 7-bit device address, except for some devices that have extended 10-bit addresses. When the master device sends a device address over the bus, the slave device with that address responds. The ADT7461 is available with one device address, 0x4C (1001 100b). The ADT7461-2 is also available with one device address, 0x4D (1001 101b).

The serial bus protocol operates as follows:

1. The master initiates data transfer by establishing a start condition, defined as a high-to-low transition on the serial data line SDATA, while the serial clock line SCLK remains high. This indicates that an address/data stream will follow. All slave peripherals connected to the serial bus respond to the start condition and shift in the next eight bits, consisting of a 7-bit address (MSB first) plus an $\overline{R/W}$ bit, which determines the direction of the data transfer, that is, whether data will be written to or read from the slave device. The peripheral whose address corresponds to the transmitted address responds by pulling the data line low during the low period before the ninth clock pulse, known as the acknowledge bit. All other devices on the bus now remain idle while the selected device waits for data to be read from or written to it. If the $\overline{R/W}$ bit is a 0, the master writes to the slave device. If the $\overline{R/W}$ bit is a 1, the master reads from the slave device.
2. Data is sent over the serial bus in a sequence of nine clock pulses, eight bits of data followed by an acknowledge bit from the slave device. Transitions on the data line must occur during the low period of the clock signal and remain stable during the high period, since a low-to-high transition when the clock is high may be interpreted as a stop signal. The number of data bytes that can be transmitted over the serial bus in a single read or write operation is limited only by what the master and slave devices can handle.
3. When all data bytes have been read or written, stop conditions are established. In write mode, the master pulls the data line high during the tenth clock pulse to assert a stop condition. In read mode, the master device overrides the acknowledge bit by pulling the data line high during the low period before the ninth clock pulse. This is known as a no acknowledge. The master then takes the data line low during the low period before the tenth clock pulse, then high during the tenth clock pulse to assert a stop condition.

Any number of bytes of data may be transferred over the serial bus in one operation, but it is not possible to mix read and write in one operation because the type of operation is determined at the beginning and cannot subsequently be changed without starting a new operation. With the ADT7461, write operations contain either one or two bytes, while read operations contain one byte.

To write data to one of the device data registers or to read data from it, the address pointer register must be set so that the correct data register is addressed. The first byte of a write operation always contains a valid address that is stored in the address pointer register. If data is to be written to the device, the write operation contains a second data byte that is written to the register selected by the address pointer register.

This is illustrated in Figure 17. The device address is sent over the bus followed by $\overline{R/W}$ set to 0. This is followed by two data bytes. The first data byte is the address of the internal data register to be written to, which is stored in the address pointer register. The second data byte is the data to be written to the internal data register. The examples shown in Figure 17 to Figure 19 use the ADT7461 SMBus Address 0x4C.

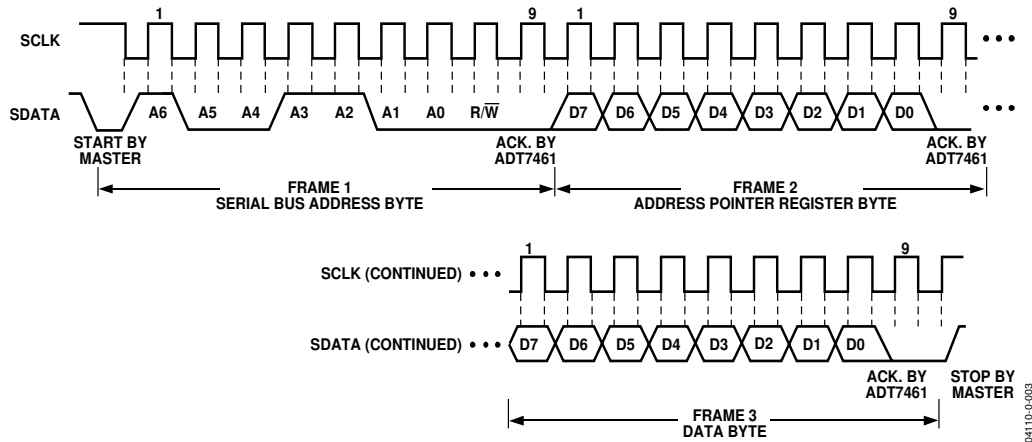

Figure 17. Writing a Register Address to the Address Pointer Register, then Writing Data to the Selected Register

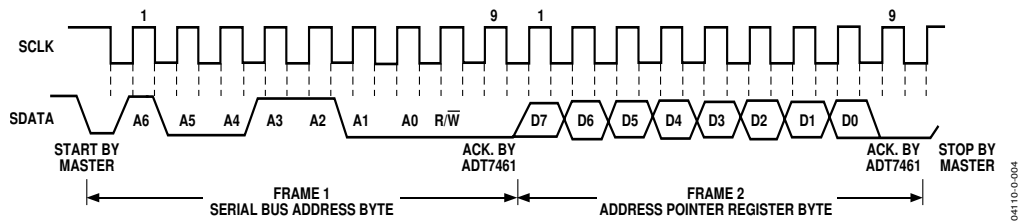

Figure 18. Writing to the Address Pointer Register Only

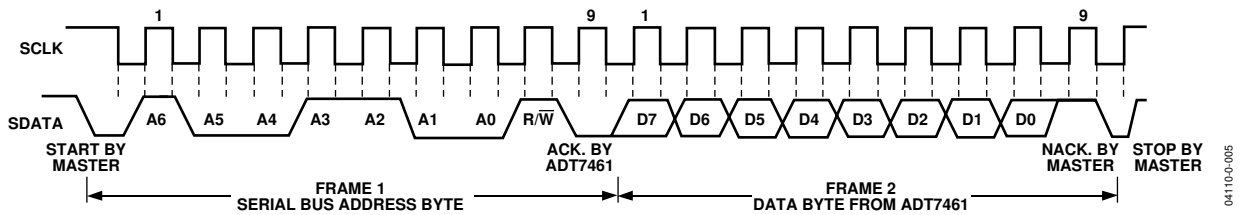

Figure 19. Reading from a Previously Selected Register

When reading data from a register there are two possibilities.

1. If the ADT7461's address pointer register value is unknown or not the desired value, it is necessary to set it to the correct value before data can be read from the desired data register. This is done by writing to the ADT7461 as before, but only the data byte containing the register read address is sent, since data is not to be written to the register. This is shown in Figure 18.
2. If the address pointer register is known to be at the desired address, data can be read from the corresponding data register without first writing to the address pointer register and the bus transaction shown in Figure 18 can be omitted.

Although it is possible to read a data byte from a data register without first writing to the address pointer register, if the address pointer register is already at the correct value, it is not possible to write data to a register without writing to the address pointer register because the first data byte of a write is always written to the address pointer register.

Also, some of the registers have different addresses for read and write operations. The write address of a register must be written to the address pointer if data is to be written to that register, but it may not be possible to read data from that address. The read address of a register must be written to the address pointer before data can be read from that register.

ALERT OUTPUT

This is applicable when Pin 6 is configured as an $\overline{\text{ALERT}}$ output. The $\overline{\text{ALERT}}$ output goes low whenever an out-of-limit measurement is detected, or if the remote temperature sensor is open circuit. It is an open-drain output and requires a pull-up to V_{DD} . Several $\overline{\text{ALERT}}$ outputs can be wire-ORed together, so the common line goes low if one or more of the $\overline{\text{ALERT}}$ outputs goes low.

The $\overline{\text{ALERT}}$ output can be used as an interrupt signal to a processor, or it may be used as an $\overline{\text{SMBALERT}}$. Slave devices on the SMBus cannot normally signal to the bus master that they want to talk, but the $\overline{\text{SMBALERT}}$ function allows them to do so.

One or more $\overline{\text{ALERT}}$ outputs can be connected to a common $\overline{\text{SMBALERT}}$ line that is connected to the master. When the $\overline{\text{SMBALERT}}$ line is pulled low by one of the devices, the procedure shown in Figure 20 occurs.

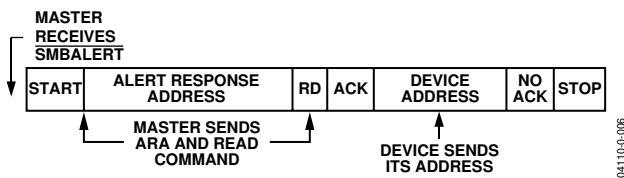

Figure 20. Use of $\overline{\text{SMBALERT}}$

1. $\overline{\text{SMBALERT}}$ is pulled low.
2. Master initiates a read operation and sends the alert response address (ARA = 0001 100). This is a general call address that must not be used as a specific device address.
3. The device whose $\overline{\text{ALERT}}$ output is low responds to the alert response address and the master reads its device address. As the device address is seven bits, an LSB of 1 is added. The address of the device is now known and can be interrogated in the usual way.
4. If the $\overline{\text{ALERT}}$ output is low on more than one device, the one with the lowest device address has priority, in accordance with normal SMBus arbitration.
5. Once the ADT7461 has responded to the alert response address, it resets its $\overline{\text{ALERT}}$ output, provided the error condition that caused the $\overline{\text{ALERT}}$ no longer exists. If the $\overline{\text{SMBALERT}}$ line remains low, the master sends the ARA again; this sequence continues until all devices whose $\overline{\text{ALERT}}$ out-puts were low have responded.

LOW POWER STANDBY MODE

The ADT7461 can be put into low power standby mode by setting Bit 6 of the configuration register. When Bit 6 is low, the ADT7461 operates normally. When Bit 6 is high, the ADC is inhibited, and any conversion in progress is terminated without writing the result to the corresponding value register.

The SMBus is still enabled. Power consumption in the standby mode is reduced to less than 10 μA if there is no SMBus activity or 100 μA if there are clock and data signals on the bus.

When the device is in standby mode, it is still possible to initiate a one-shot conversion of both channels by writing to the one-shot register (Address 0x0F), after which the device returns to standby. It does not matter what is written to the one-shot register, as all data written to it is ignored. It is also possible to write new values to the limit register while in standby mode. If the values stored in the temperature value registers are now outside the new limits, an $\overline{\text{ALERT}}$ is generated even though the ADT7461 is still in standby.

SENSOR FAULT DETECTION

At its D+ input, the ADT7461 contains internal sensor fault detection circuitry. This circuit can detect situations where an external remote diode is either not connected or incorrectly connected to the ADT7461. A simple voltage comparator trips if the voltage at D+ exceeds $V_{\text{DD}} - 1\text{ V}$ (typical), signifying an open circuit between D+ and D-. The output of this comparator is checked when a conversion is initiated. Bit 2 of the status register (open flag) is set if a fault is detected. If the $\overline{\text{ALERT}}$ pin is enabled, setting this flag causes $\overline{\text{ALERT}}$ to assert low.

If the user does not wish to use an external sensor with the ADT7461, then to prevent continuous setting of the OPEN flag, the user should tie the D+ and D- inputs together.

THE ADT7461 INTERRUPT SYSTEM

The ADT7461 has two interrupt outputs, $\overline{\text{ALERT}}$ and $\overline{\text{THERM}}$. Both have different functions and behavior. $\overline{\text{ALERT}}$ is maskable and responds to violations of software-programmed temperature limits or an open-circuit fault on the external diode. $\overline{\text{THERM}}$ is intended as a fail-safe interrupt output that cannot be masked.

If the external or local temperature exceeds the programmed high temperature limits or equals or exceeds the low temperature limits, the $\overline{\text{ALERT}}$ output is asserted low. An open-circuit fault on the external diode also causes $\overline{\text{ALERT}}$ to assert. $\overline{\text{ALERT}}$ is reset when serviced by a master reading its device address, provided the error condition has gone away and the status register has been reset.

The $\overline{\text{THERM}}$ output asserts low if the external or local temperature exceeds the programmed $\overline{\text{THERM}}$ limits. $\overline{\text{THERM}}$ temperature limits should normally be equal to or greater than the high temperature limits. $\overline{\text{THERM}}$ is reset automatically when the temperature falls back within the $\overline{\text{THERM}}$ limit. The external limit is set by default to 85°C, as is the local $\overline{\text{THERM}}$ limit. A hysteresis value can be programmed so that $\overline{\text{THERM}}$ resets when the temperature falls to the limit value minus the hysteresis value. This applies to both local and remote measurement channels. The power-on hysteresis default value is 10°C, but this may be reprogrammed to any value after power-up.

The hysteresis loop on the $\overline{\text{THERM}}$ outputs is useful when $\overline{\text{THERM}}$ is used for on/off control of a fan. The user's system can be set up so that when $\overline{\text{THERM}}$ asserts, a fan can be switched on to cool the system. When $\overline{\text{THERM}}$ goes high again, the fan can be switched off. Programming an hysteresis value protects from fan jitter where the temperature hovers around the $\overline{\text{THERM}}$ limit, and the fan is constantly being switched.

Table 13. $\overline{\text{THERM}}$ Hysteresis

$\overline{\text{THERM}}$ Hysteresis	Binary Representation
0°C	0 000 0000
1°C	0 000 0001
10°C	0 000 1010

Figure 21 shows how the $\overline{\text{THERM}}$ and $\overline{\text{ALERT}}$ outputs operate. A user may choose to use the $\overline{\text{ALERT}}$ output as an $\overline{\text{SMBALERT}}$ to signal to the host via the $\overline{\text{SMBus}}$ that the temperature has risen. The user could use the $\overline{\text{THERM}}$ output to turn on a fan to cool the system, if the temperature continues to increase. This method would ensure there is a fail-safe mechanism to cool the system without the need for host intervention.

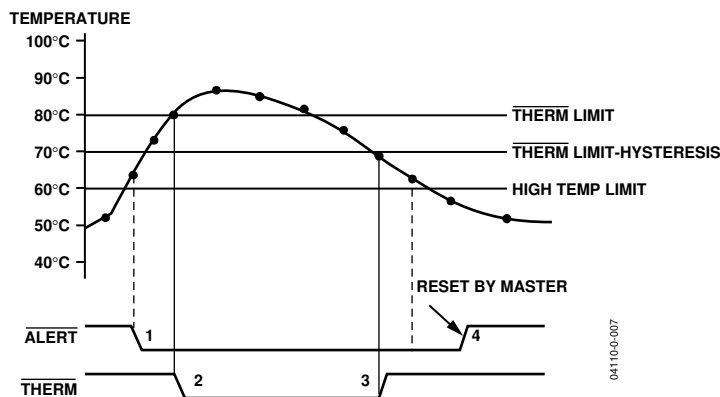

Figure 21. Operation of the $\overline{\text{ALERT}}$ and $\overline{\text{THERM}}$ Interrupts

1. If the measured temperature exceeds the high temperature limit, the $\overline{\text{ALERT}}$ output asserts low.
2. If the temperature continues to increase and exceeds the $\overline{\text{THERM}}$ limit, the $\overline{\text{THERM}}$ output asserts low. This can be used to throttle the CPU clock or switch on a fan.

3. The $\overline{\text{THERM}}$ output deasserts (goes high) when the temperature falls to $\overline{\text{THERM}}$ limit minus hysteresis. The default hysteresis value of 10°C is shown in Figure 21.
4. The $\overline{\text{ALERT}}$ output deasserts only when the temperature falls below the high temperature limit, and the master has read the device address and cleared the status register.

Pin 6 on the ADT7461 can be configured as either an $\overline{\text{ALERT}}$ output or as an additional $\overline{\text{THERM}}$ output. $\overline{\text{THERM2}}$ asserts low when the temperature exceeds the programmed local and/or remote high temperature limits. It is reset in the same manner as $\overline{\text{THERM}}$, and it is not maskable. The programmed hysteresis value applies to $\overline{\text{THERM2}}$ also.

Figure 22 shows how $\overline{\text{THERM}}$ and $\overline{\text{THERM2}}$ might operate together to implement two methods of cooling the system. In this example, the $\overline{\text{THERM2}}$ limits are set lower than the $\overline{\text{THERM}}$ limits. The $\overline{\text{THERM2}}$ output could be used to turn on a fan. If the temperature continues to rise and exceeds the $\overline{\text{THERM}}$ limits, the $\overline{\text{THERM}}$ output could provide additional cooling by throttling the CPU.

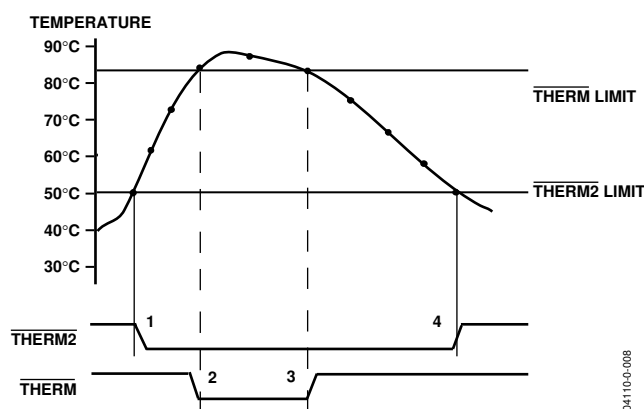

Figure 22. Operation of the $\overline{\text{THERM}}$ and $\overline{\text{THERM2}}$ Interrupts

1. When the $\overline{\text{THERM2}}$ limit is exceeded, the $\overline{\text{THERM2}}$ signal asserts low.
2. If the temperature continues to increase and exceeds the $\overline{\text{THERM}}$ limit, the $\overline{\text{THERM}}$ output asserts low.
3. The $\overline{\text{THERM}}$ output deasserts (goes high) when the temperature falls to $\overline{\text{THERM}}$ limit minus hysteresis. No hysteresis value is shown in Figure 22.
4. As the system continues to cool and the temperature falls below the $\overline{\text{THERM2}}$ limit, the $\overline{\text{THERM2}}$ signal resets. Again, no hysteresis value is shown for $\overline{\text{THERM2}}$.

Both the external and internal temperature measurements cause $\overline{\text{THERM}}$ and $\overline{\text{THERM2}}$ to operate as described.

APPLICATION INFORMATION

Noise Filtering

For temperature sensors operating in noisy environments, the industry standard practice was to place a capacitor across the D+ and D- pins to help combat the effects of noise. However, large capacitances affect the accuracy of the temperature measurement, leading to a recommended maximum capacitor value of 1,000 pF. While this capacitor reduces the noise, it does not eliminate it, making it difficult to use the sensor in a very noisy environment.

The ADT7461 has a major advantage over other devices for eliminating the effects of noise on the external sensor. The series resistance cancellation feature allows a filter to be constructed between the external temperature sensor and the part. The effect of any filter resistance seen in series with the remote sensor is automatically cancelled from the temperature result.

The construction of a filter allows the ADT7461 and the remote temperature sensor to operate in noisy environments. Figure 23 shows a low-pass R-C-R filter with the following values: R = 100 Ω and C = 1 nF. This filtering reduces both common-mode noise and differential noise.

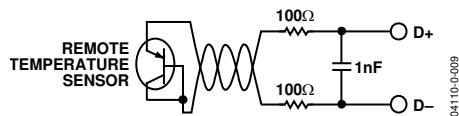

Figure 23. Filter Between Remote Sensor and ADT7461
Factors Affecting Diode Accuracy

Remote Sensing Diode

The ADT7461 is designed to work with substrate transistors built into processors or with discrete transistors. Substrate transistors are generally PNP types with the collector connected to the substrate. Discrete types can be either PNP or NPN transistor connected as a diode (base-short to collector). If an NPN transistor is used, the collector and base are connected to D+ and the emitter to D-. If a PNP transistor is used, the collector and base are connected to D- and the emitter to D+.

To reduce the error due to variations in both substrate and discrete transistors, several factors should be taken into consideration:

- The ideality factor, n_F , of the transistor is a measure of the deviation of the thermal diode from ideal behavior. The ADT7461 is trimmed for an n_F value of 1.008. The following equation may be used to calculate the error introduced at a temperature T (°C), when using a transistor whose n_F does not equal 1.008. Consult the processor data sheet for the n_F values.

$$\Delta T = (n_F - 1.008) / 1.008 \times (273.15 \text{ Kelvin} + T)$$

To factor this in, the user can write the ΔT value to the offset register. It is then automatically added to or subtracted from the temperature measurement by the ADT7461.

- Some CPU manufacturers specify the high and low current levels of the substrate transistors. The high current level of the ADT7461, I_{HIGH} , is 96 μA, and the low level current, I_{LOW} , is 6 μA. If the ADT7461 current levels do not match the current levels specified by the CPU manufacturer, it may become necessary to remove an offset. The CPU's data sheet advises whether this offset needs to be removed and how to calculate it. This offset may be programmed to the offset register. It is important to note that if more than one offset must be considered, the algebraic sum of these offsets must be programmed to the offset register.

If a discrete transistor is being used with the ADT7461, the best accuracy is obtained by choosing devices according to the following criteria:

- Base-emitter voltage greater than 0.25 V at 6 μA, at the highest operating temperature.
- Base-emitter voltage less than 0.95 V at 100 μA, at the lowest operating temperature.
- Base resistance less than 100 Ω.
- Small variation in h_{FE} (50 to 150) that indicates tight control of V_{BE} characteristics.

Transistors, such as the 2N3904, 2N3906, or equivalents in SOT-23 packages are suitable devices to use.

THERMAL INERTIA AND SELF-HEATING

Accuracy depends on the temperature of the remote sensing diode and/or the internal temperature sensor being at the same temperature as the environment being measured; many factors can affect this. Ideally, the sensor should be in good thermal contact with the part of the system being measured. If it is not, the thermal inertia caused by the sensor's mass causes a lag in the response of the sensor to a temperature change. With a remote sensor, this should not be a problem since it will be either a substrate transistor in the processor or a small package device, such as the SOT-23, placed in close proximity to it.

The on-chip sensor, however, is often remote from the processor and only monitors the general ambient temperature around the package. The thermal time constant of the SOIC-8 package in still air is about 140 seconds, and if the ambient air temperature quickly changed by 100 degrees, it would take about 12 minutes (5 time constants) for the junction temperature of the ADT7461 to settle within 1 degree of this. In practice, the ADT7461 package is in electrical, and hence thermal, contact with a PCB and may also be in a forced airflow. How accurately the temperature of the board and/or the forced airflow reflects the temperature to be measured also affects the accuracy. Self-heating due to the power dissipated in the ADT7461 or the remote sensor causes the chip temperature of the device or remote sensor to rise above ambient.

However, the current forced through the remote sensor is so small that self-heating is negligible. With the ADT7461, the worst-case condition occurs when the device is converting at 64 conversions per second while sinking the maximum current of 1 mA at the ALERT and THERM output. In this case, the total power dissipation in the device is about 4.5 mW. The thermal resistance, θ_{JA} , of the SOIC-8 package is about 121°C/W.

LAYOUT CONSIDERATIONS

Digital boards can be electrically noisy environments, and the ADT7461 is measuring very small voltages from the remote sensor, so care must be taken to minimize noise induced at the sensor inputs. The following precautions should be taken:

1. Place the ADT7461 as close as possible to the remote sensing diode. Provided the worst noise sources, such as clock generators, data/address buses, and CRTs, are avoided, this distance can be 4 inches to 8 inches.
2. Route the D+ and D- tracks close together, in parallel, with grounded guard tracks on each side. To minimize inductance and reduce noise pick-up, a 5 mil track width and spacing is recommended. Provide a ground plane under the tracks if possible.



Figure 24. Typical Arrangement of Signal Tracks

3. Try to minimize the number of copper/solder joints that can cause thermocouple effects. Where copper/solder joints are used, make sure that they are in both the D+ and D- path and at the same temperature.

Thermocouple effects should not be a major problem as 1°C corresponds to about 200 mV, and thermocouple voltages are about 3 mV/°C of temperature difference. Unless there are two thermocouples with a big temperature differential between them, thermocouple voltages should be much less than 200 mV.

4. Place a 0.1 μ F bypass capacitor close to the V_{DD} pin. In extremely noisy environments, an input filter capacitor may be placed across D+ and D- close to the ADT7461. This capacitance can effect the temperature measurement, so care must be taken to ensure any capacitance seen at D+ and D- is a maximum of 1,000 pF. This maximum value includes the filter capacitance plus any cable or stray capacitance between the pins and the sensor diode.
5. If the distance to the remote sensor is more than 8 inches, the use of twisted pair cable is recommended. This works up to about 6 feet to 12 feet.

For extremely long distances (up to 100 feet), use a shielded twisted pair, such as the Belden No. 8451 microphone cable. Connect the twisted pair to D+ and D- and the shield to GND close to the ADT7461. Leave the remote end of the shield unconnected to avoid ground loops.

Because the measurement technique uses switched current sources, excessive cable or filter capacitance can affect the measurement. When using long cables, the filter capacitance may be reduced or removed.

ADT7461

APPLICATION CIRCUIT

Figure 25 shows a typical application circuit for the ADT7461 using a discrete sensor transistor connected via a shielded, twisted pair cable. The pull-ups on SCLK, SDATA, and ALERT are required only if they are not already provided elsewhere in the system.

The SCLK and SDATA pins of the ADT7461 can be interfaced directly to the SMBus of an I/O controller, such as the Intel® 820 chipset.

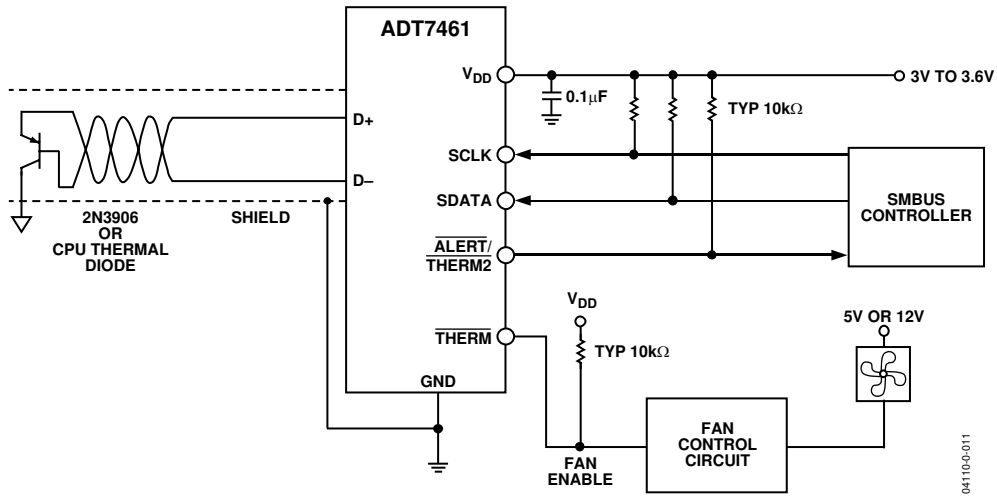
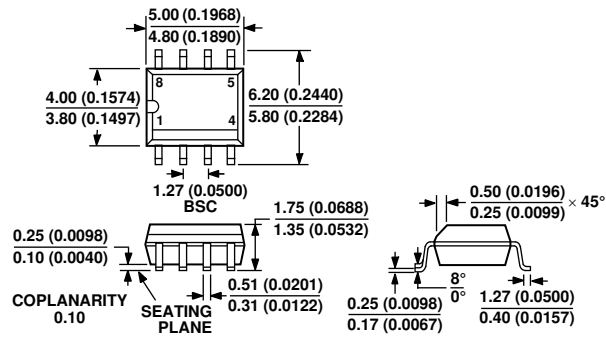

Figure 25. Typical Application Circuit

04110-0-011

OUTLINE DIMENSIONS



COMPLIANT TO JEDEC STANDARDS MS-012-AA
 CONTROLLING DIMENSIONS ARE IN MILLIMETERS; INCH DIMENSIONS (IN PARENTHESES) ARE ROUNDED-OFF MILLIMETER EQUIVALENTS FOR REFERENCE ONLY AND ARE NOT APPROPRIATE FOR USE IN DESIGN

Figure 26. 8-Lead Standard Small Outline Package [SOIC_N]
 Narrow Body
 (R-8)

Dimensions shown in millimeters and (inches)

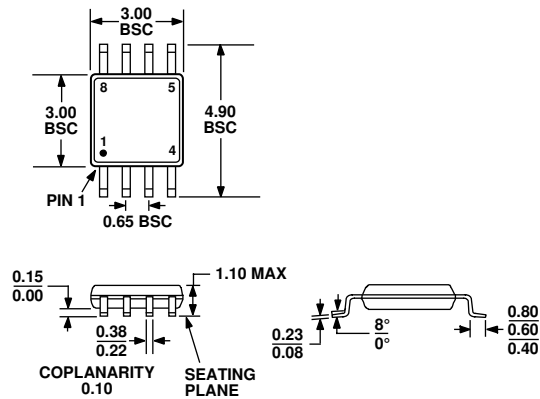

COMPLIANT TO JEDEC STANDARDS MO-187-AA

Figure 27. 8-Lead Mini Small Outline Package [MSOP]
 (RM-8)

Dimensions shown in millimeters

ADT7461

ORDERING GUIDE

Model	Temperature Range	Package Description	Package Option	Branding	SMBus Address
ADT7461AR	-40°C to +125°C	8-Lead SOIC_N	R-8		4C
ADT7461AR-REEL	-40°C to +125°C	8-Lead SOIC_N	R-8		4C
ADT7461AR-REEL7	-40°C to +125°C	8-Lead SOIC_N	R-8		4C
ADT7461ARZ ¹	-40°C to +125°C	8-Lead SOIC_N	R-8		4C
ADT7461ARZ-REEL ¹	-40°C to +125°C	8-Lead SOIC_N	R-8		4C
ADT7461ARZ-REEL7 ¹	-40°C to +125°C	8-Lead SOIC_N	R-8		4C
ADT7461ARM	-40°C to +125°C	8-Lead MSOP	RM-8	T1B	4C
ADT7461ARM-REEL	-40°C to +125°C	8-Lead MSOP	RM-8	T1B	4C
ADT7461ARM-REEL7	-40°C to +125°C	8-Lead MSOP	RM-8	T1B	4C
ADT7461ARMZ ¹	-40°C to +125°C	8-Lead MSOP	RM-8	T1B	4C
ADT7461ARMZ-REEL ¹	-40°C to +125°C	8-Lead MSOP	RM-8	T1B	4C
ADT7461ARMZ-REEL7 ¹	-40°C to +125°C	8-Lead MSOP	RM-8	T1B	4C
ADT7461ARMZ-2 ¹	-40°C to +125°C	8-Lead MSOP	RM-8	T1F	4D
ADT7461ARMZ-2REEL ¹	-40°C to +125°C	8-Lead MSOP	RM-8	T1F	4D
ADT7461ARMZ-2REEL7 ¹	-40°C to +125°C	8-Lead MSOP	RM-8	T1F	4D
EVAL-ADT7461EB		Evaluation Board			

¹ Z = Pb-free part.

NOTES

ADT7461

NOTES