

**(b)**  
**NOTES:**

1. FOR WAVESOLDERING (SOLDER BATH TEMPERATURE 265°C FOR 8 SEC. AND SOLDER PREHEAT 150°C FOR 180 SEC.)
2. IP RATING: IP 67
3. SEALED TO WITHSTAND PRESSURE UP TO 1,45 PSI FOR 30 MINUTES AFTER HIGH TEMPERATURE EXPOSURE
4. METAL SHELL:  
ZINC DIE CAST; min. 50µin NICKEL PLATING over COPPER
5. INSULATORS: PBT GF UL 94 V-0, BLACK
6. O-RING: SILICONE PER ASTM D2000 70 SHORE A
7. SEALING COMPOUND: EPOXY RESIN UL 94 V-0; BLACK
8. CONTACTS: COPPER ALLOY  
PLATING (SEE PART NO):  
 PLEASE ADD 1 for 30µin HARD GOLD over min. 50µin NICKEL  
 PLEASE ADD 3 for 8µin HARD GOLD over min. 50µin NICKEL
9. METAL BRACKETS: ZINC DIE CAST;  
300µin COPPER/40-120µin NICKEL/120-200µin TIN
10. WASHERS: COPPER ALLOY; 80µin NICKEL
11. HEXLOCKING SCREWS: STAINLESS STEEL
12. PCB-SNAPS: COPPER ALLOY; min. 200µin TIN over 80µin NICKEL  
PCB-HOLE:  $\varnothing 3.1 \pm 0.1$ ; PCB THICKNESS 1.6mm
13. P.C.B. HOLE DRILLINGS and RECOMMENDED PANEL CUT-OUT ON SHEET 2
14. RECOMMENDED TORQUE FOR MOUNTING SCREW 35Ncm (3.1 in.LB) / max.67Ncm (6 in.LB)
15. CONNECTOR IS PART MARKED: 15-00078 □ CONEC ABC

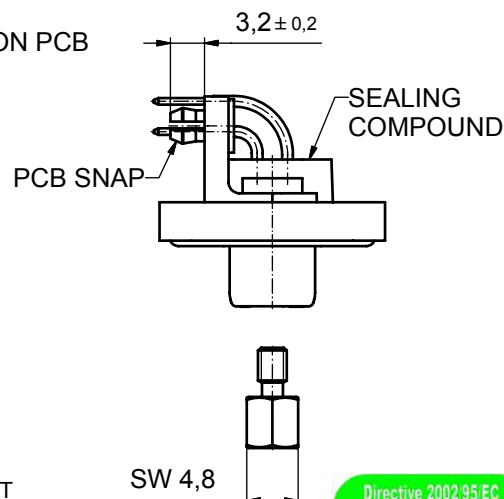

**(d)**  
AT ALL TIMES WATER RESISTANT CONNECTORS NOT IN USE SHOULD BE COVERED WITH A CONEC WATER RESISTANT CAP OR WATER TIGHT HOOD.

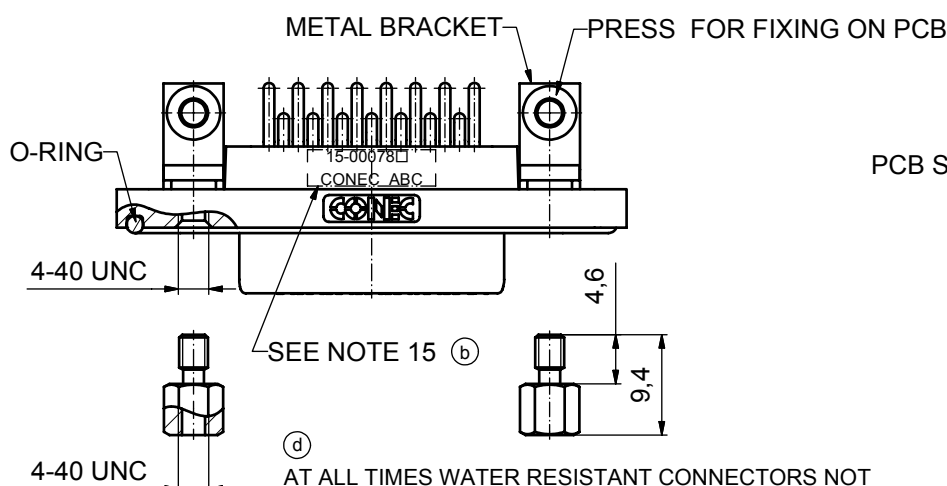
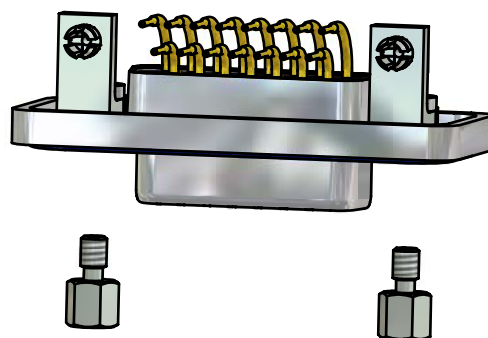
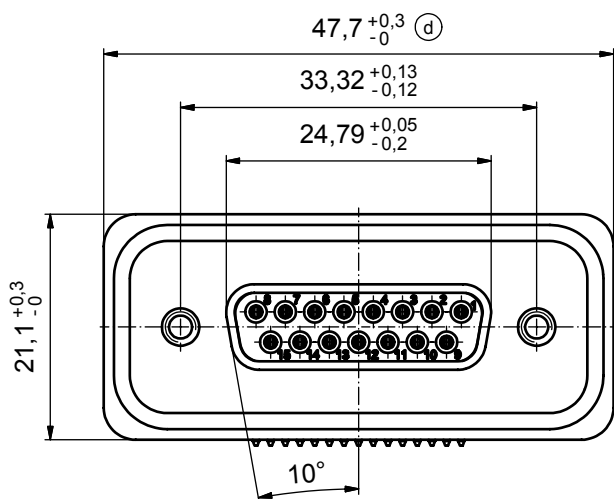
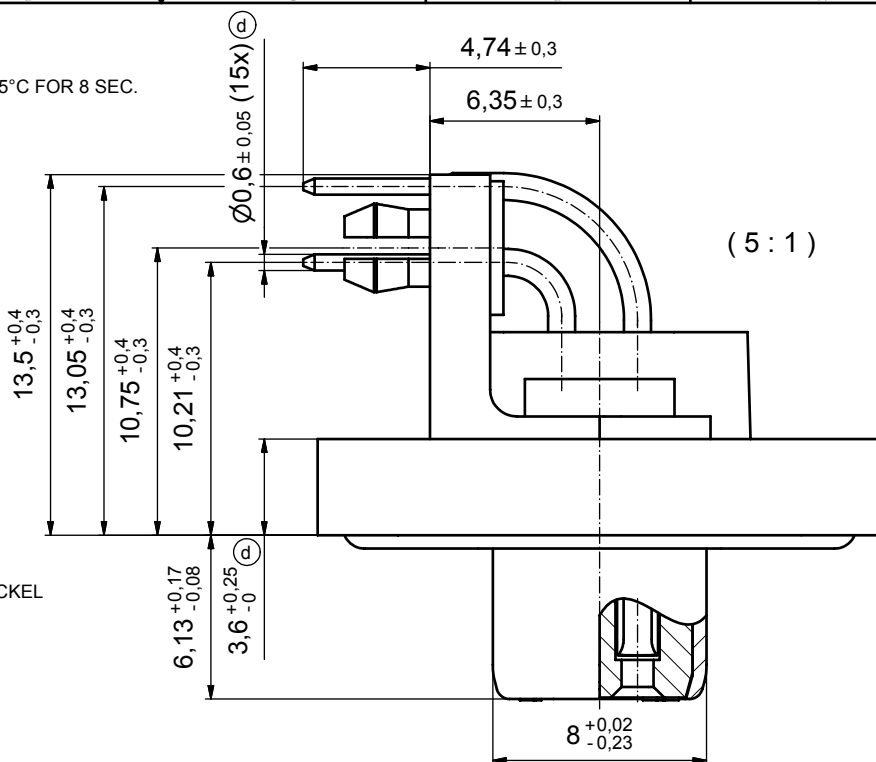

APPROVAL # FREIGABE # DEBLOCAGE # AUTORIZACION # APPROVAL	
CUSTOMER APPROVAL DATE:	
NAME:	TITLE:
COMPANY NAME:	
APPROVAL # FREIGABE # DEBLOCAGE # AUTORIZACION # APPROVAL	

THIS DRAWING MAY NOT BE COPIED OR REPRODUCED IN ANY WAY, AND MAY NOT BE PASSED ON TO A THIRD PARTY WITHOUT WRITTEN PERMISSION. OWNERSHIP AND COPYRIGHT OF CONEC GmbH				tolerance		dim. in mm	
DO NOT ALTER CAD DRAWING BY HAND				date		name	
				drawn		12.09.08 Schmidt	
				appd.		15.09.08 Fischer	
				norm			
				d-old			
4 x d	A 3435	05.10.09	HS				
3 x b	A 3129	26.09.08	Petker				
a	Origin						
rev.	description	date	name	<b>CONEC</b>			

scale:		2:1 (5:1)	
material:		see notes	
title:			
D-SUB FEMALE 90° 15pos. SOLDER PIN ANGLED with metal bracket, hexlocking screw and snap			
dwg no:		Inventor 10	
		DIN-A3	
		sh: 1	
part no:		15-00078 □ (see note 8) (b)	

# P.C.B. HOLE DRILLINGS

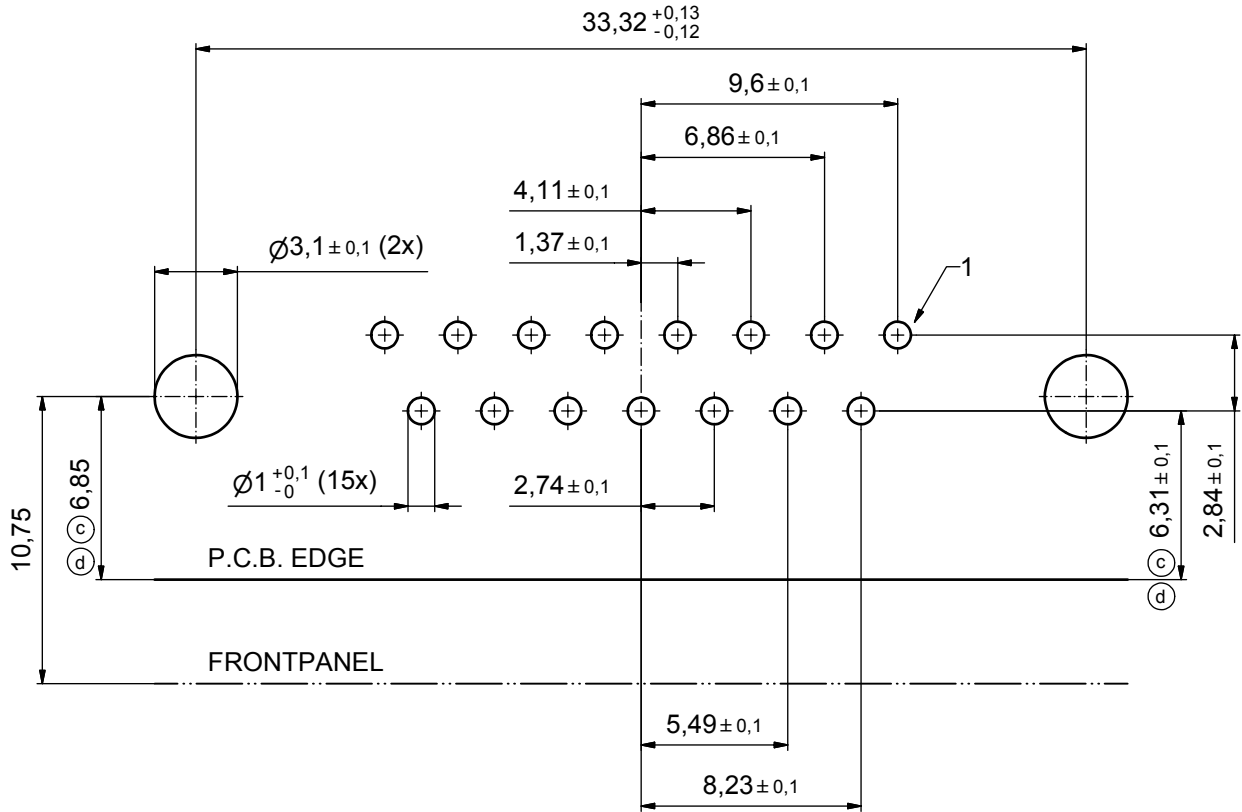

# RECOMMENDED PANEL CUT-OUT

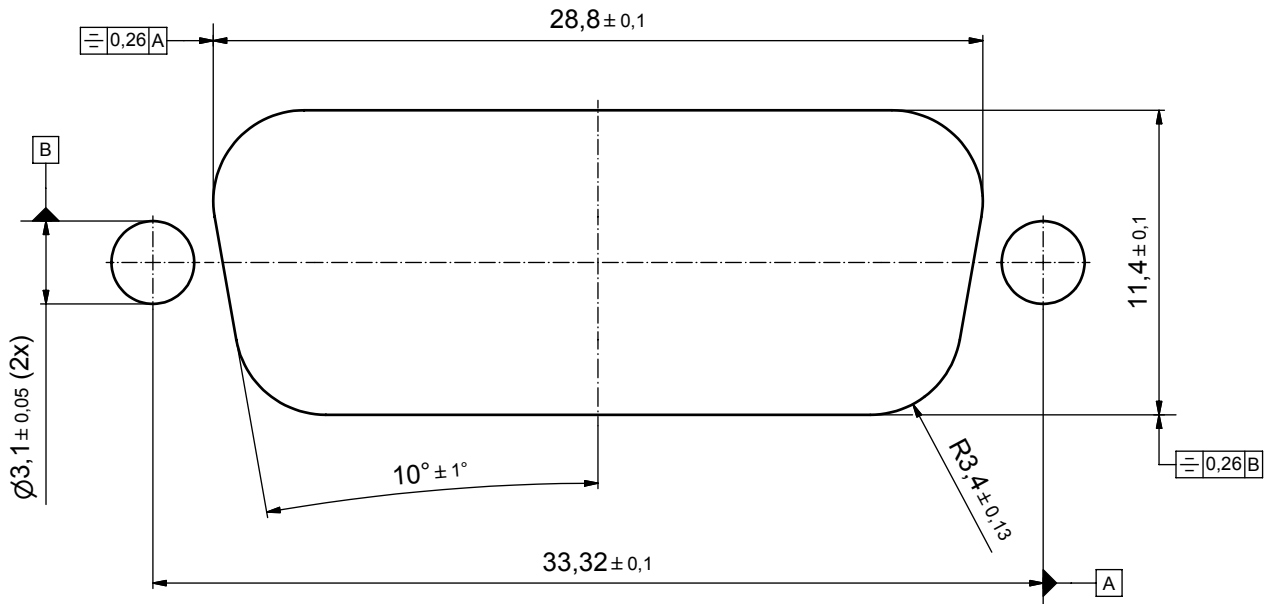

APPROVAL # FREIGABE # DEBLOCAGE # AUTORIZACION # APPROVAL	
CUSTOMER APPROVAL DATE:	
NAME:	TITLE:
COMPANY NAME:	
APPROVAL # FREIGABE # DEBLOCAGE # AUTORIZACION # APPROVAL	

THIS DRAWING MAY NOT BE COPIED OR REPRODUCED IN ANY WAY, AND MAY NOT BE PASSED ON TO A THIRD PARTY WITHOUT WRITTEN PERMISSION. OWNERSHIP AND COPYRIGHT OF CONEC GmbH				tolerance		dim. in mm	
DO NOT ALTER CAD DRAWING BY HAND				date	name		
				drawn	12.09.08	Schmidt	
				appd.	15.09.08	Fischer	
2 x d	Ä 3435	05.10.09	HS	norm			
2 x c	Ä 3344	15.04.09	HS	d-old			
1 x b	Ä 3129	26.09.08	Petker				
a	Origin						
rev.	description	date	name				

scale:	5:1		
material:	see sheet 1		
title:	P.C.B. HOLE DRILLINGS PANEL CUT-OUT D-SUB Female 15pos. Solder pin angled 90°		
dwg no:	Inventor 10	DIN-A3	
	15K1A253	sh: 2	
part no:	see sheet 1		

