

# MOA. Horizontal toggle clamps

with folded base, steel



- 1
- 2
- 3
- 4
- 5
- 6
- 7
- 8
- 9
- 10
- 11
- 12
- 13
- 14
- 15
- 16
- 17
- 18

## MATERIAL

C10 zinc-plated steel.

## RIVETS

Zinc-plated steel.

## SUPPORT BUSHINGS

Hardened and ground steel (for sizes  $\geq 355$ ).

## HANDLE

Polyurethane, red colour.

## STANDARD EXECUTIONS

- **MOA-M**: with open clamping lever and two folded washers.
- **MOA-O**: with solid clamping lever and bolt retainer.

## CLAMPING BOLT (TO BE ORDERED SEPARATELY)

## FEATURES AND APPLICATIONS

All articulated joints are lubricated with special grease.

Main feature of MOA toggle clamps is the low clamping profile. These tools are designed to avoid that the operator's fingers may be hit by the lever while opening. During clamping, the lever is controlled to prevent impact on functioning due to side thrust.

During clamping, the lever is controlled to prevent impact on functioning due to side thrust.

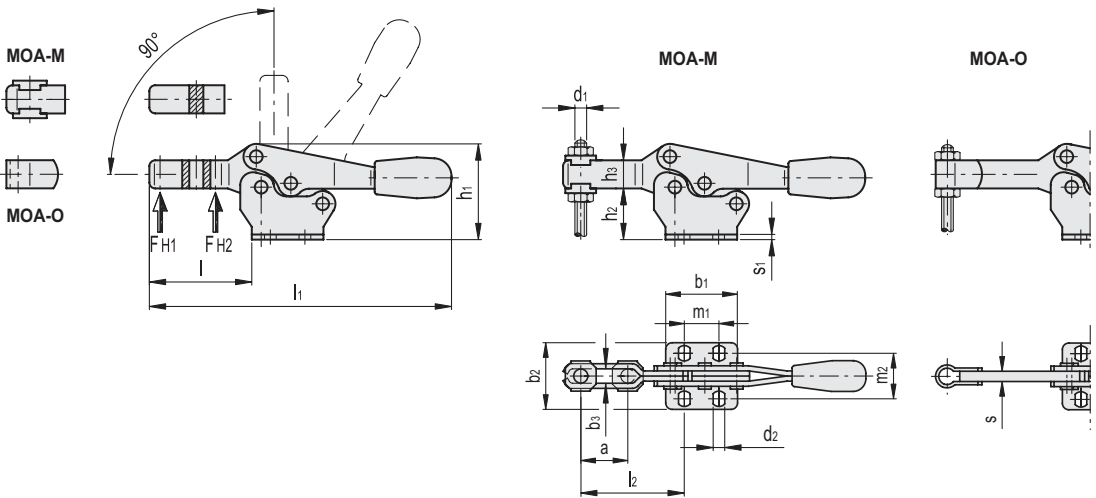
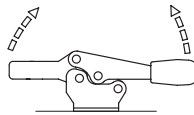

## MOA-M

**METRIC**

Code	Description	a	b1	b2	b3	d1	d2	h1	h2	h3	l	l1	l2	m1	m2	s1	FH1* [N]	FH2* [N]	$\Delta$
GG.AD025	MOA.25-M	10	24	24.5	4.2	M4	4.3	23	12	7	19	68	20	15	16	1.2	400	-	25
GG.AD075	MOA.75-M	20	28	26	5.5	M5	4.5	37	20	11	40	118	40	13.5	16+19	2	900	1350	88
GG.AD135	MOA.130-M	32	36	40	6.5	M6	5.5	51	29	16	56	170	53	26	22.4+28.4	2.5	1000	2000	200
GG.AD270	MOA.230-M	37	44	42	8.5	M8	6.5	61.5	36.5	18	65	195	63.5	26	26+31.5	3	1700	3300	330
GG.AD370	MOA.355-M	58	60	56	10	M10	8.5	83	50	22	100	269	96	41	38.8+43	3.5	1800	4000	700
GG.AD470	MOA.455-M	65	70	65	12.4	M12	8.5	98.5	60	26	115	308	116	41.5	40+43	4	3200	6200	1200

## MOA-O

**METRIC**

Code	Description	b1	b2	d1	d2	h1	h2	h3	l	l1	m1	m2	s	s1	FH1* [N]	FH2* [N]	$\Delta$
GG.AD085	MOA.75-O	28	26	M5	4.5	37	20	11	40.5	118.5	13.5	16+19	4	2	900	1350	88
GG.AD145	MOA.130-O	36	40	M6	5.5	51	29	16	57	171	26	22.4+28.4	5	2.5	1000	2000	200
GG.AD280	MOA.230-O	44	42	M8	6.5	61.5	36.5	18	67	197	26	26+31.5	6	3	1700	3300	340
GG.AD380	MOA.355-O	60	56	M10	8.5	83	50	22	102	271	41	38.8+43	7	3.5	1800	4000	720
GG.AD480	MOA.455-O	70	65	M12	8.5	98.5	60	26	117	310	41.5	40+43	10	4	3200	6200	1230

Toggle clamps

\* Holding force.