

RECOMMENDED LAND PATTERN :

Zone A must be attached to heat sink. Thermal conductivity of intermediate layers between Zone A and heat sink must be better than 0.1 W / [°C x mm].

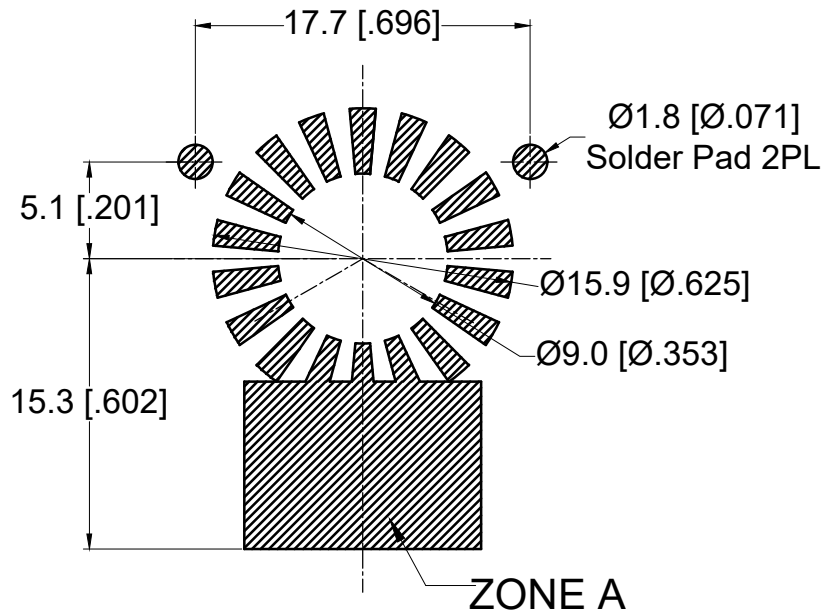

PCB MATERIAL:ROGERS 4350B 20MIL

ELECTRICAL SPECIFICATION :

- Frequency Range : 2110 to 2170 MHz
- Isolation (In Band) : 28 dB Min
- Insertion Loss : 0.18 dB Max
- FWD Power : 150W (CW)
- Peak Power : 1000 W
- REV Power : 60 W
- Return Loss : 25 dB Min
- IMD (2 x 65 W, 1 MHz space) : -70 dBc Max
- 2nd Harmonics : 10 dBc
- 3rd Harmonics : 5 dBc
- Operating Temperature : -40°C to +120°C
- +120°C to +130°C : power capacity and reliability no change , other spec.reduce 10%
- Storage Temperature : -40°C to +130°C
- Direction : CW

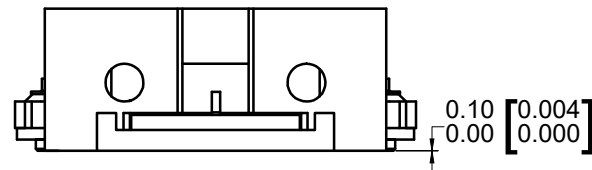
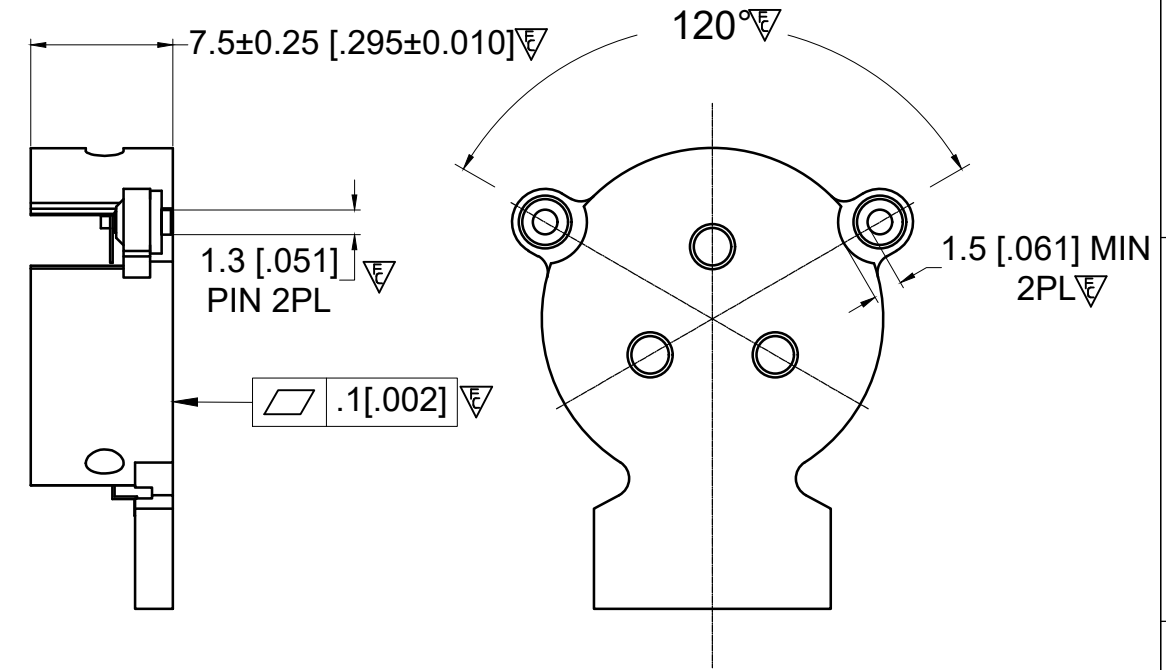
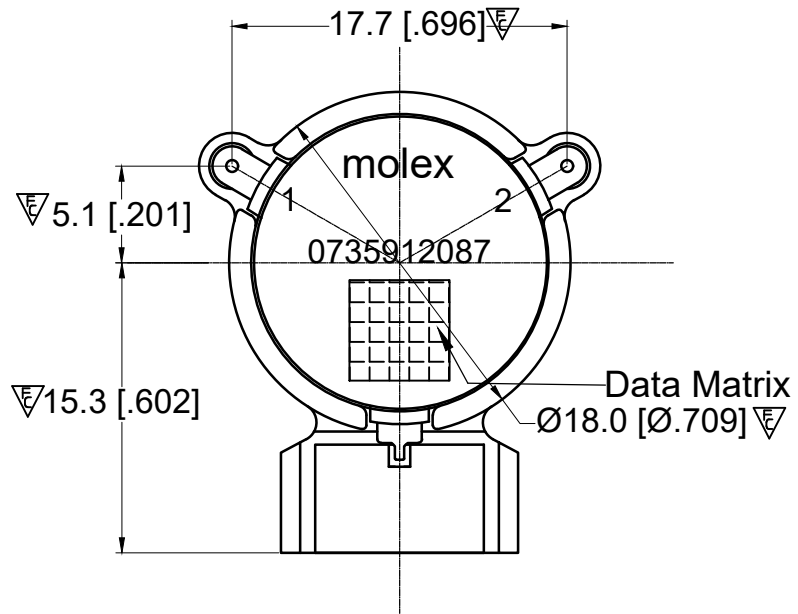

BODY: CARBON STEEL, SILVER PLATED
RIGID PINS: COPPER, SILVER PLATED

NOTES:

1. STANDARD INPUT/OUTPUT IMPEDANCE 50 OHM
2. LEAD FREE, NO ND MATERIAL, BEO FREE
- 3.THE DIMENSION OF THE DATA MATRIX IS 5.3MM*5.3MM, INFORMATION INCLUDED WORK ORDER NUMBER-SERIAL NUMBER-MATERIAL NUMBER
- 4.THIS PART COMPLIES WITH ALL ROHS REQUIREMENTS.

ENG PART#: 801-211-217-WC140

FUNCTIONAL SYMBOLS	THIS DRAWING CONTAINS INFORMATION THAT IS PROPRIETARY TO MOLEX ELECTRONIC TECHNOLOGIES, LLC AND SHOULD NOT BE USED WITHOUT WRITTEN PERMISSION										
	DIMENSION UNITS		SCALE		CURRENT REV DESC:				molex		
MM		1:1		RELEASE TO PROD							
DIVISIONAL SYMBOLS	GENERAL TOLERANCES (UNLESS SPECIFIED)										
	mm		INCH		EC NO: 696580				SMSJ ISOLATOR/2110~2170MHZ/CW		
4 PLACES ±0.005 ±----		±----		DRWN: SREN05 2022/02/21							
3 PLACES ±0.025 ±----		±----		CHK'D: JLI252 2022/02/23				RESTRICTED PRODUCT CUSTOMER DRAWING			
2 PLACES ±0.13 ±----		±----		APPR: HWANG186 2022/03/01							
1 PLACE ±0.25 ±----		±----		INITIAL REVISION:				DOCUMENT NUMBER			
0 PLACES ±0.4 ±----		±----		DRWN: SREN05 2021/12/08							
ANGULAR TOL ± 1.5 °		±----		APPR: HWANG186 2022/03/01				735912087			
DRAFT WHERE APPLICABLE MUST REMAIN WITHIN DIMENSIONS		THIRD ANGLE PROJECTION		DRAWING		SERIES		MATERIAL NUMBER		CUSTOMER	
		A3-SIZE		73591		0735912087		CUSTOM PART		SHEET NUMBER	
										1 OF 1	

DOCUMENT STATUS	P1	RELEASE DATE	2022/03/01	06:07:31
-----------------	----	--------------	------------	----------