

UNIT:MM

REVISION INFORMATION

Rev.	Rev. Date	Modified By	Brief Description
A/0	18-07-03	T0702A	NEW DRAWING
A/1	18-08-30	B0829A	修改成型胶粒硬度

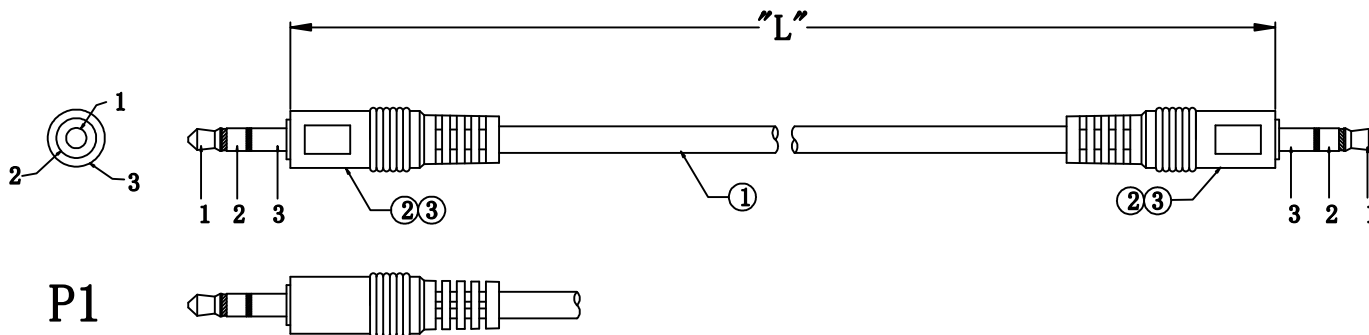

PIN ASSIGNMENT

P1		P2	
1	RED	1	
2	BLACK	2	
3	BRAID	3	

PART NO	WIRE LENGTH "L"	BUYER COLOR	VENDOR COLOR	CUT LENGTH
770-10040-00100	1000±30		BLACK	1000-1010MM

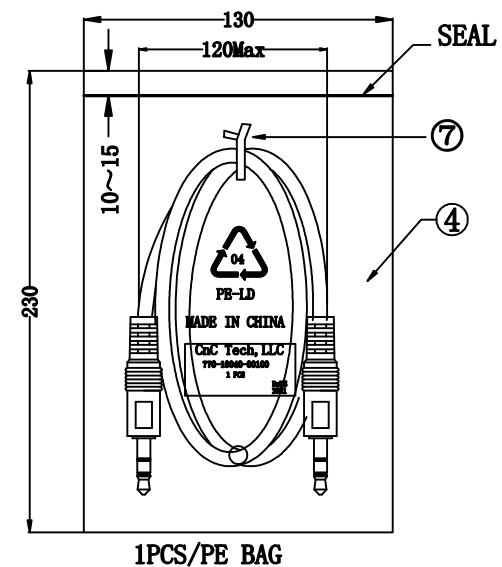

NO.	NAME	Q'TY	SPECIFICATION
⑦	TIE	1	BLACK L=70MM
⑥	TUBE	2	HEAT SHRINK TUBE BLACK OD1.5*L15MM
⑤	PE BAG	1/10	CLEAR SIZE:280X330X0.05mm PRINT BLACK"MADE IN CHINA "+"10PCS"
④	PE BAG	1	CLEAR SIZE:130X230X0.05mm PRINT BLACK "MADE IN CHINA"
③	OUT JACKET		PVC 55P COLOR:BLACK (MOULD NO:WM-20)
②	CONN	2	3.5ST MALE Tray6.0mm L=30mm MOLD TYPE NI-PLATED INSULATOR COLOR:BLACK
①	CABLE	1	NOUL 28AWG (7/0.12TC) X2C (RED, WHITE)+(36/0.12) JACKET BLACK OD:3.0MM

CnC Tech, LLC
Industrial Cable and Connector Technology

DRAWN BY:	DATE: 2018/08/30	DESCRIPTION: 2C CABLE DC3.5+DC3.5
CHECKED BY:	SHEET 1 of 1	ITEM NO. As above
APPROVED BY:	SCALE 1:1	REV. A/1 UNIT: mm