

CM1206A601R-10

PHYSICAL DIMENSIONS:

A	3.20 [.126]	+ 0.20 [.008]
B	1.60 [.063]	+ 0.20 [.008]
C	1.80 [.071]	+ 0.20 [.008]
D	0.15 [.006]	+ 0.10 [.004]

T1	0.60 [.024]	+ 0.10 [.004]
T2	0.60 [.024]	+ 0.10 [.004]

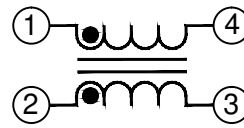
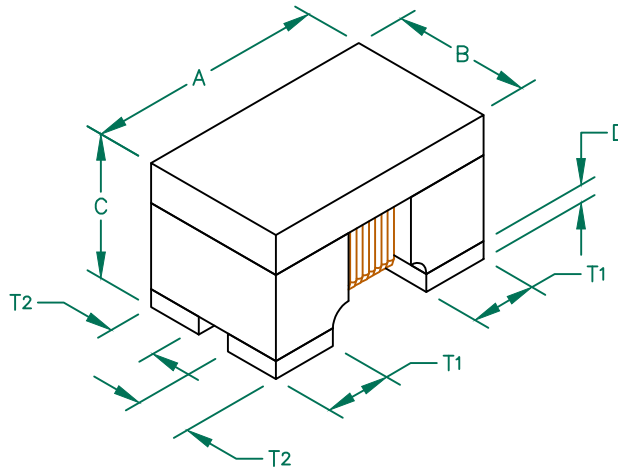

LAND PATTERNS FOR REFLOW SOLDERING

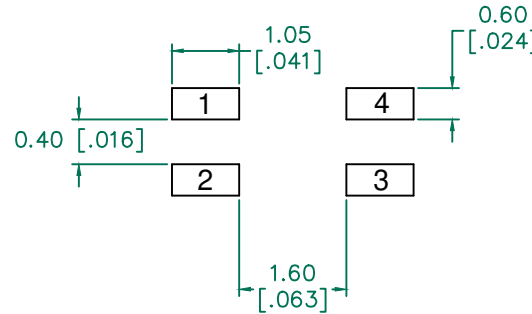

Electrical Characteristics	Nominal	Min	Max
Common Mode Impedance @ 100MHz	(Ω) 600	450	750
DCR	(Ω) -	-	0.80
Rated Current	(mA) -	-	260

- NOTES: UNLESS OTHERWISE SPECIFIED
1. TAPED AND REELED per CURRENT EIA SPECIFICATIONS 7" REELS, EMBOSSED PLASTIC TAPE 2,000 PCS/REEL.
 2. TERMINATION FINISH 100% MATTE TIN.
 3. COMPONENTS SHOULD BE ADEQUATELY PREHEATED BEFORE SOLDERING.
 4. OPERATING TEMP. RANGE: $-40^{\circ}\text{C} \sim +125^{\circ}\text{C}$. (INCLUDING SELF-HEATING)

RECOMMENDED SOLDERING CONDITIONS

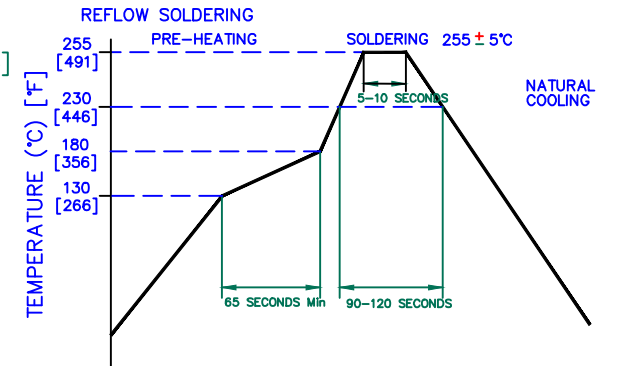

Z, R, XL vs. FREQUENCY

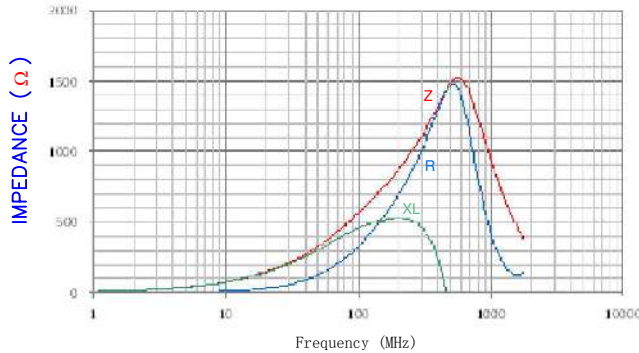

Z vs. FREQUENCY (C,N,O)

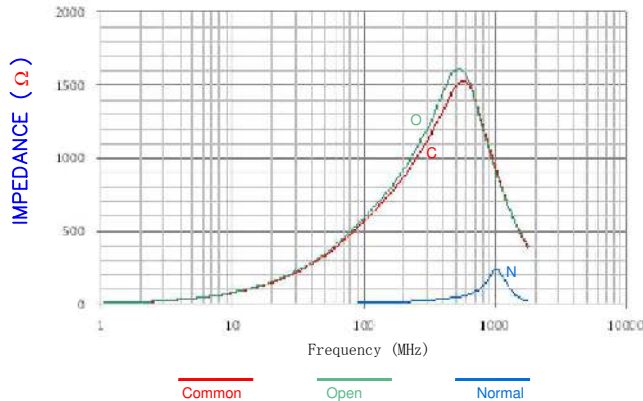

RoHS

DIMENSIONS ARE IN mm [INCHES].				This print is the property of Laird Tech. and is loaned in confidence subject to return upon request and with the understanding that no copies shall be made without the written consent of Laird Tech. All rights to design or invention are reserved.			
PROJECT/PART NUMBER:				REV B PART TYPE: CM CHOKE DRAWN BY: JUN			
B ADD OPERATING TEMPERATURE UPDATE LAIRD LOGO AND REFLOW CURVE 08/05/13 QU				CM1206A601R-10			
A ORIGINAL DRAFT 06/11/10 JUN				DATE: 06/11/10 SCALE: NTS			
REV DESCRIPTION				CAD # CM1206A601R-10-B TOOL # - SHEET: 1 of 1			