

THIS DRAWING IS UNPUBLISHED. RELEASED FOR PUBLICATION  
 © COPYRIGHT - By - ALL RIGHTS RESERVED.

REVISIONS					
P	LTR	DESCRIPTION	DATE	DWN	APVD
C2		ADDED ALUMINIUM WIRE RANGE	05NOV19	MB	PKS

- 1 CONTINUOUS STRIP ON REELS WITH TERMINALS LOCATED ON 8.38±0.08 [.330±.003] CENTERS.
- 2 SLOT TERMINATES EITHER A SINGLE OR DOUBLE MAGNET WIRES OF THE SAME TYPE AND SIZE, COPPER RANGE: 0.36-0.57mm [#27-#23] AWG. ALUMINIUM RANGE: 0.51-0.64mm [#24-#22] AWG. ALUMINIUM WIRE RANGE APPLIES FOR POST TIN PLATED PARTS ONLY.
- 3 AFTER INSERTION INTO PLASTIC HOLDER TAB PORTION MUST BE BENT OVER 45° TO 90° OR POTTED-IN TO PREVENT PULL-OUT WHEN MATING RECEPTACLE IS DISCONNECTED.
- 4 CAVITY SPECIFICATION TO BE MODIFIED TO ACCEPT WIDER TAB TRANSITION.

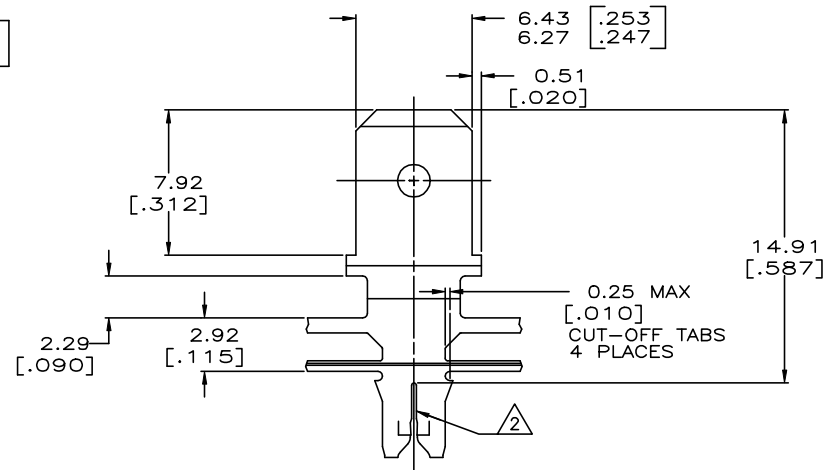
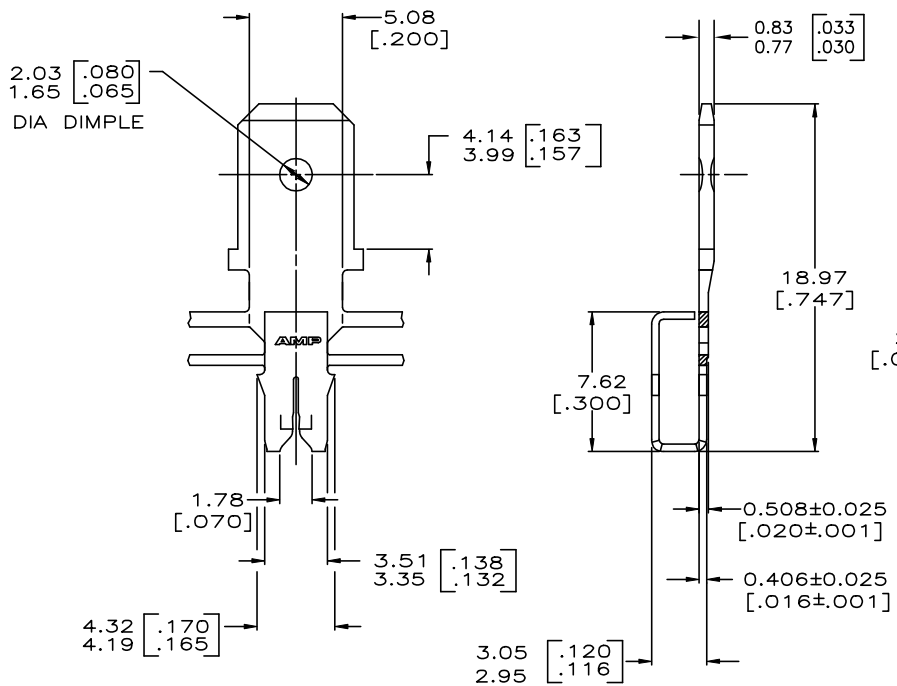

63920-1  
PART NUMBER

THIS DRAWING IS A CONTROLLED DOCUMENT.		DWN MICHAEL S. FEHER 10JUL96	TE Connectivity	
DIMENSIONS: INCHES		CHK RICHARD GRZYBOWSKI 11JUL96	APVD GARY PORTA 12JUL96	
TOLERANCES UNLESS OTHERWISE SPECIFIED:		NAME TAB, 6.35[.250] FASTON™ MAG-MATE™		
0 PLC ± -		PRODUCT SPEC 108-2012		
1 PLC ± -		APPLICATION SPEC 114-2046 4		
2 PLC ± 0.25(.010)		SIZE A2		
3 PLC ± -		CAGE CODE 00779		
4 PLC ± -		DRAWING NO C=63920		
ANGLES ± -		RESTRICTED TO -		
FINISH TIN PLATE		WEIGHT -		
MATERIAL BRASS		SCALE 5:1		
		SHEET 1 of 1		
		REV C2		