

OPERATING FORCES FOR COVER
 Betätigungskräfte am Deckel
 OPEN / öffnen: 35 N ± 8 N
 CLOSE / schließen: 15 N ± 8 N

- NOTES
 Bemerkungen
- 1 TE LOGO AND TE ASSY-NUMBER
TE Logo und TE Assy-Nummer
 - 2 CAVITY MARKING
Nestmarkierung
 - 3 PRODUCTION DATE
Produktionsdatum
 - 4 MATERIAL MARKING ACC. TO VDA 260
Werkstoffkennzeichnung nach VDA 260
 - 5 REVISION OF THE MOLD
Werkzeugänderungsindex
 - 6 OPERATING FREE SPACE
Betätigungsfreiraum
 - 7 ON BOARD DIAGNOSE MARKING
Fahrzeuginnen Kennzeichnung
 - 8 FITS TO 16POS. REC. HOUSING PN 1418984
Passend zu 16pol. Buchsengehäuse 1418984
 - 9 LAYER PACKAGING IN CORRUGATED BOX
Lagenverpackung im Versandkarton
 - 10 TE PART-NUMBER
TE Teile-Nummer

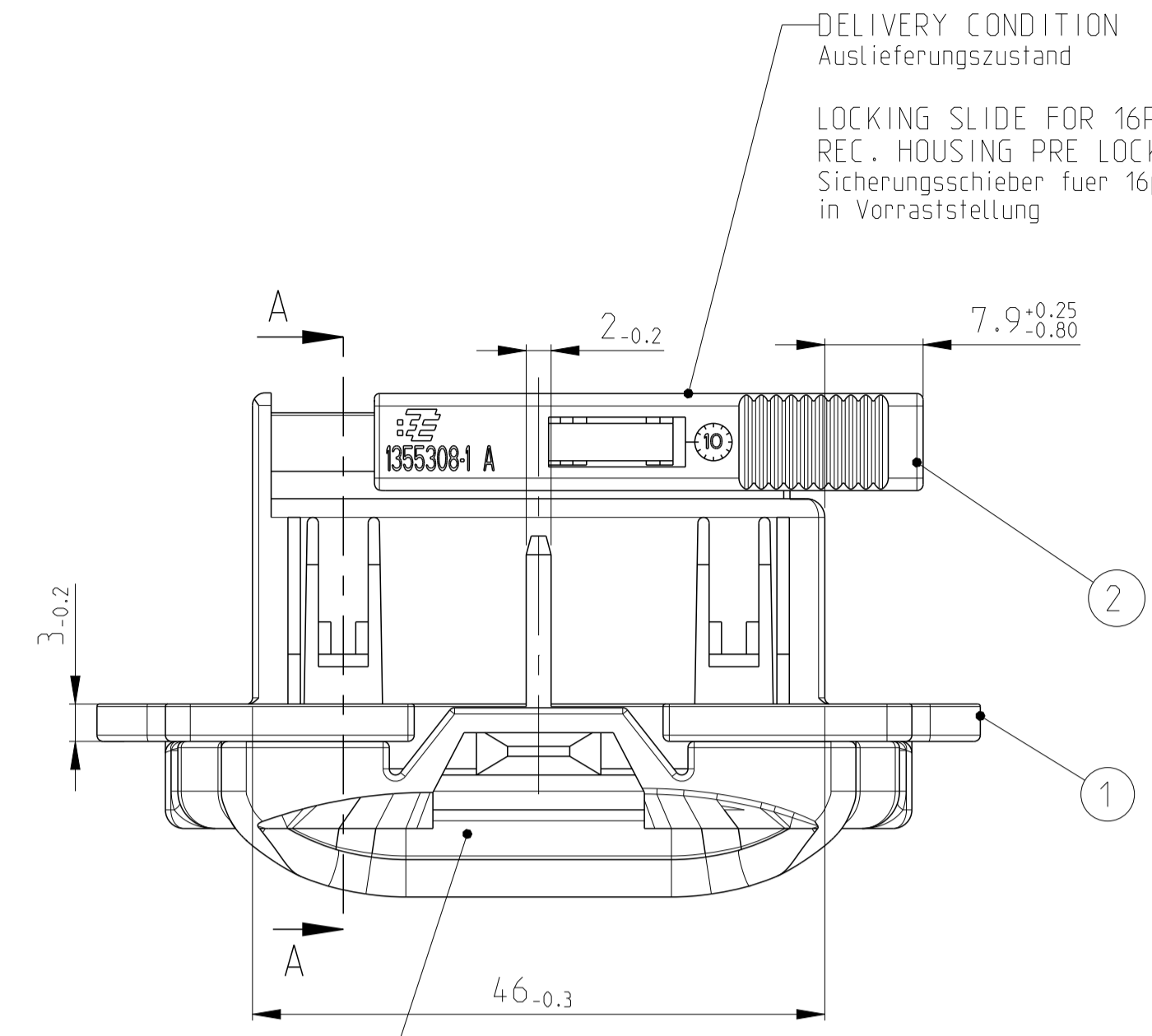

DELIVERY CONDITION
 Auslieferungszustand
 COVER CLOSED
 Deckel geschlossen

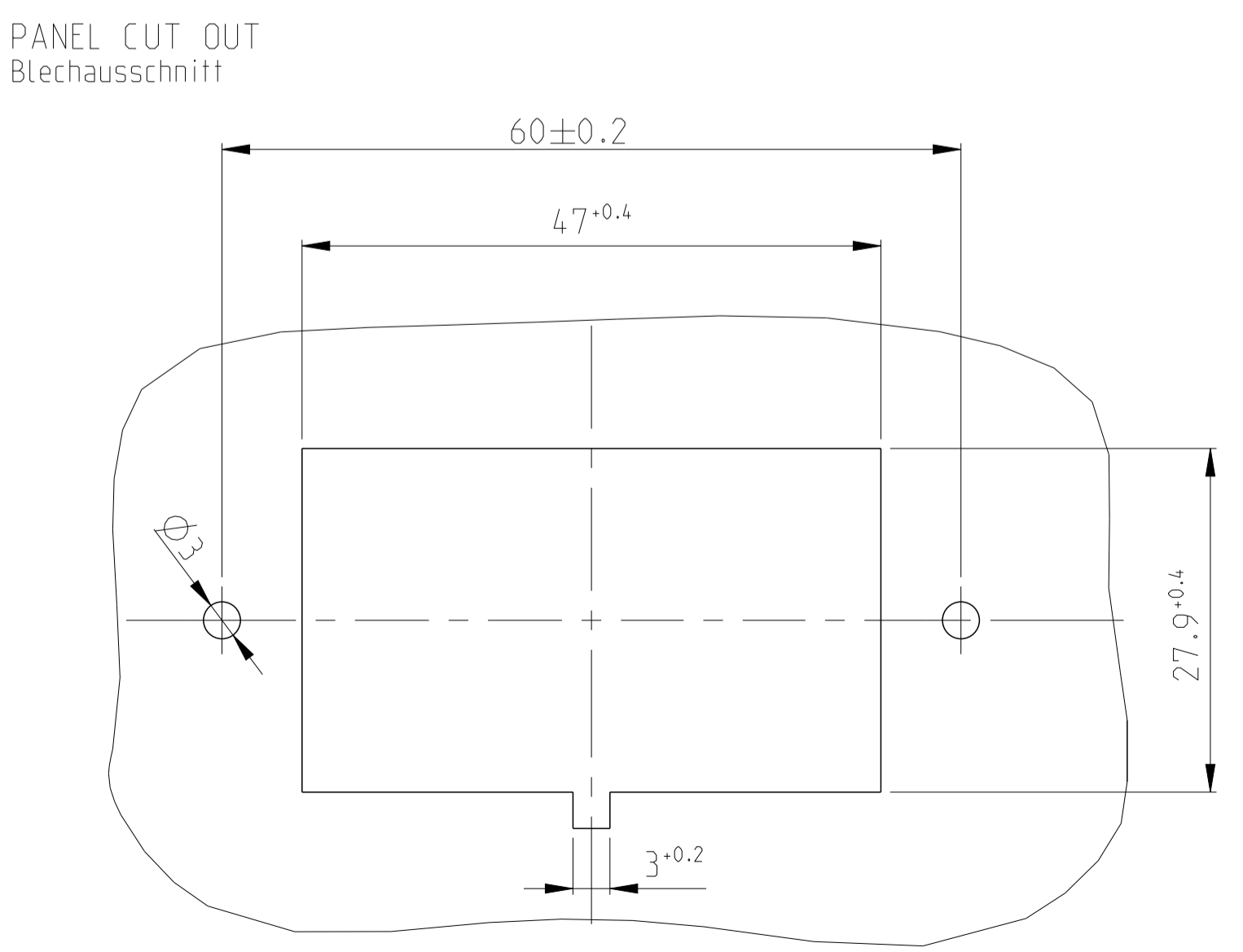
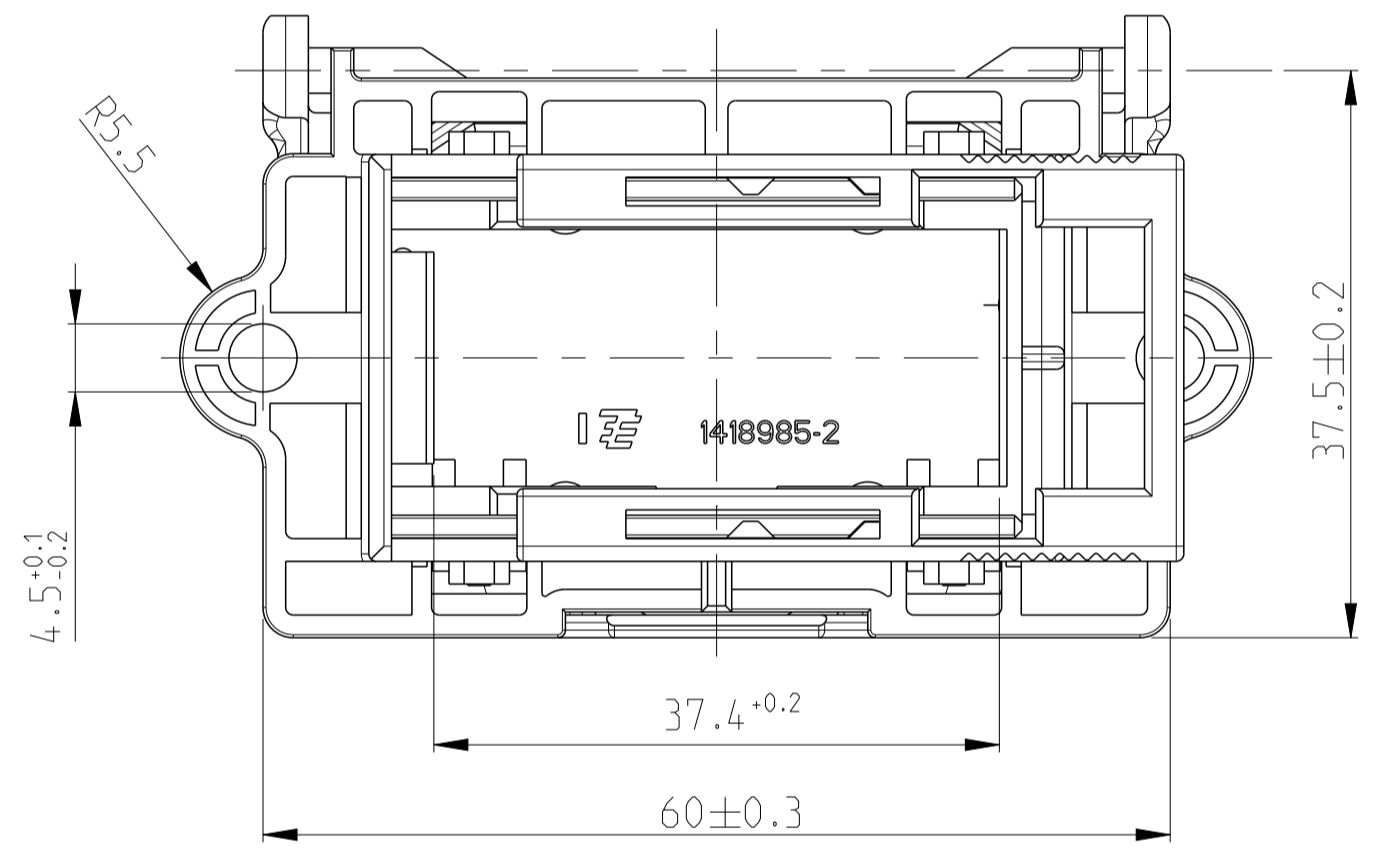
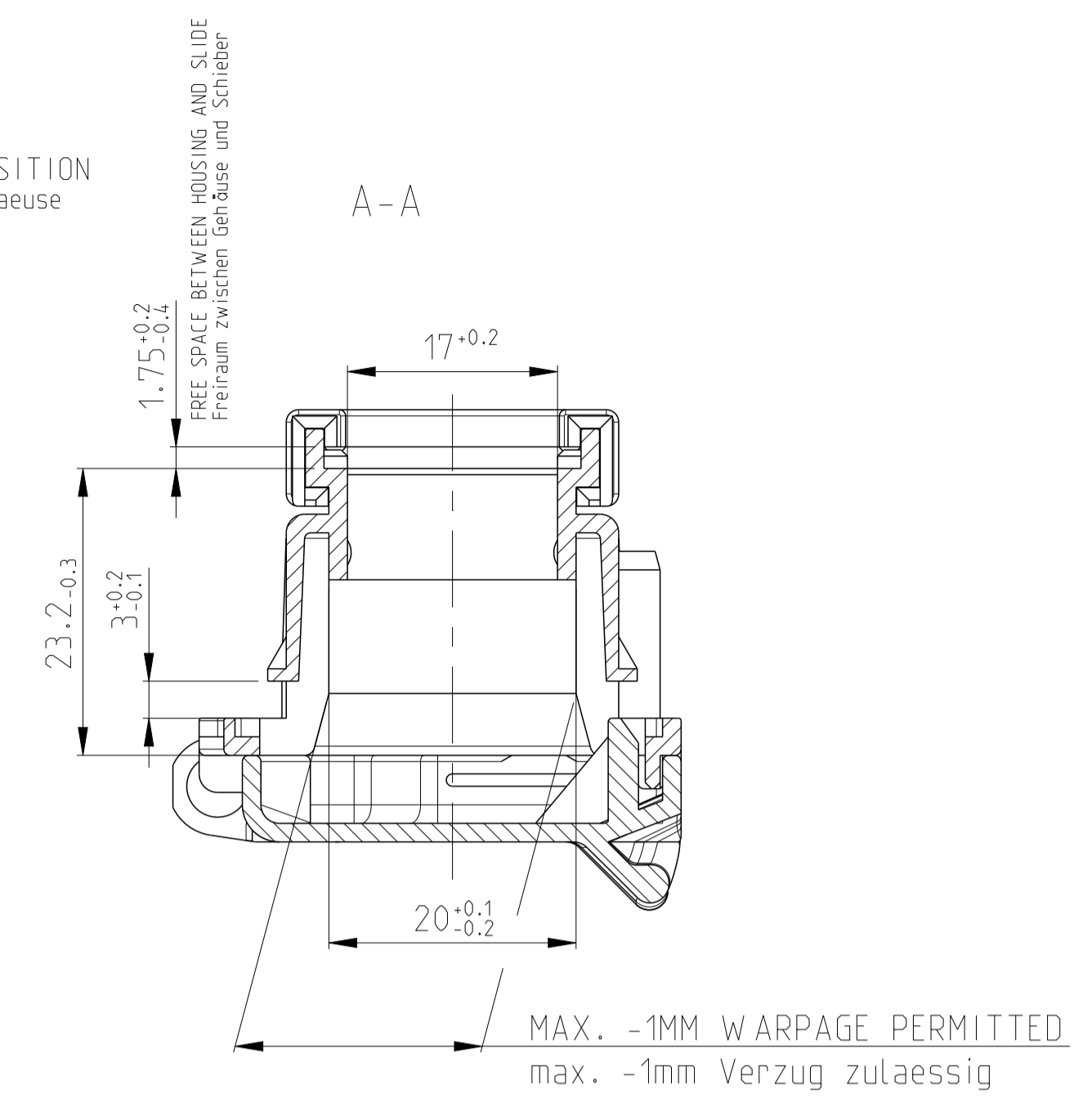

MATERIAL THICKNESS t=2.5±0.2mm
 Materialdicke t=2.5±0.2mm

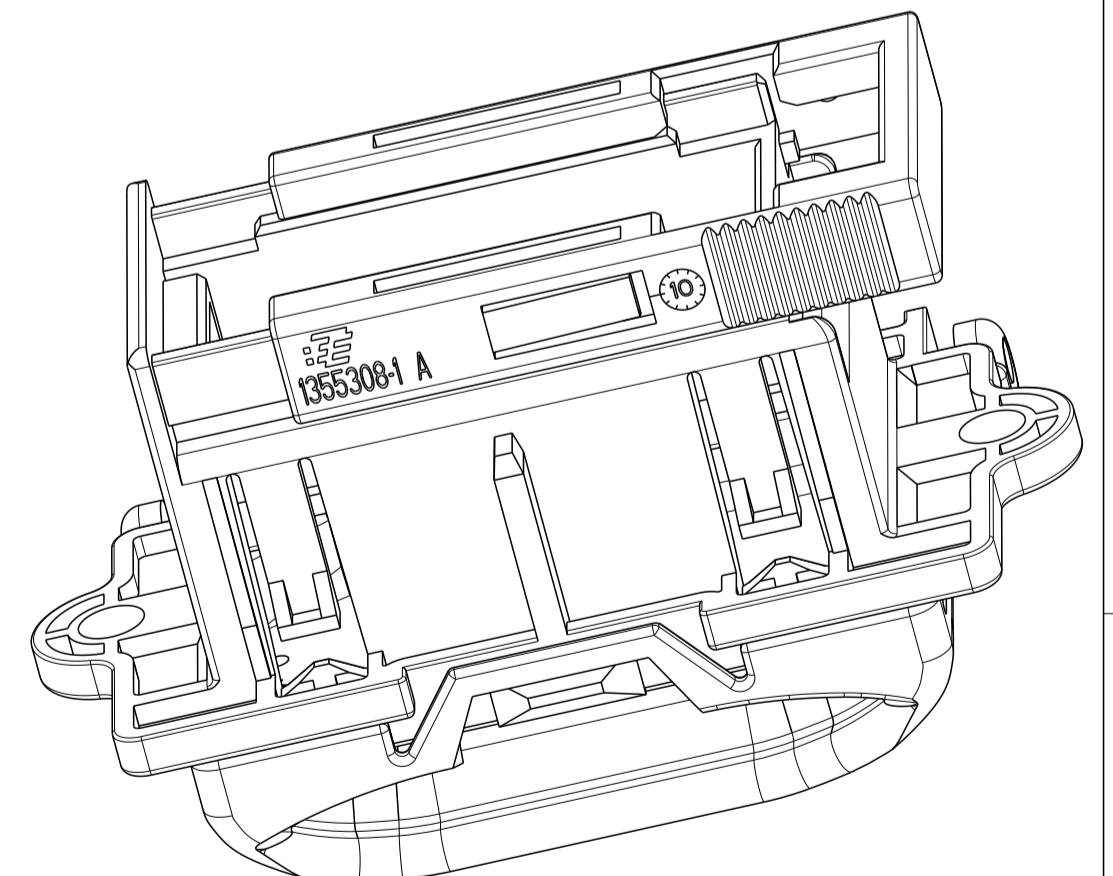
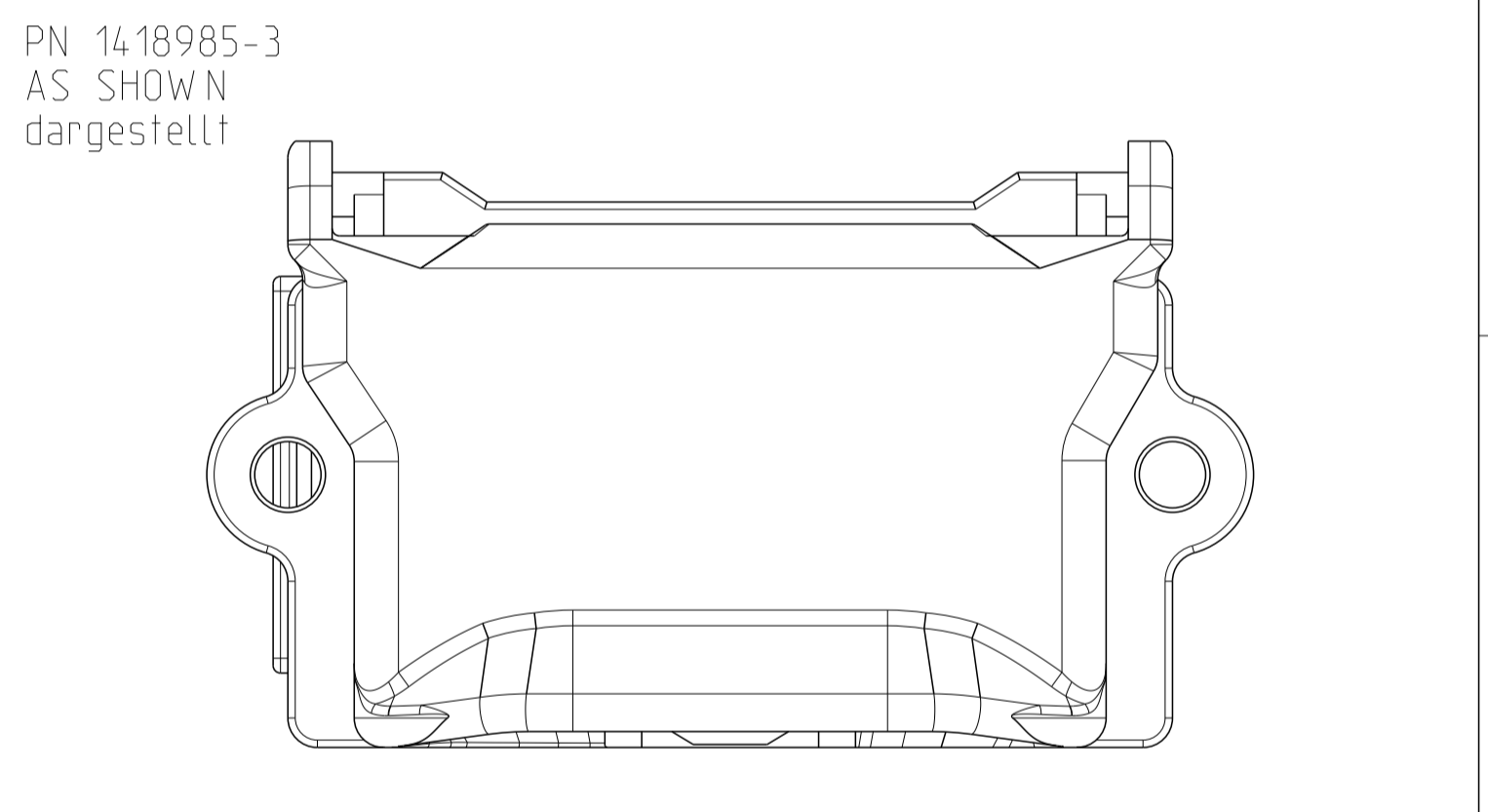
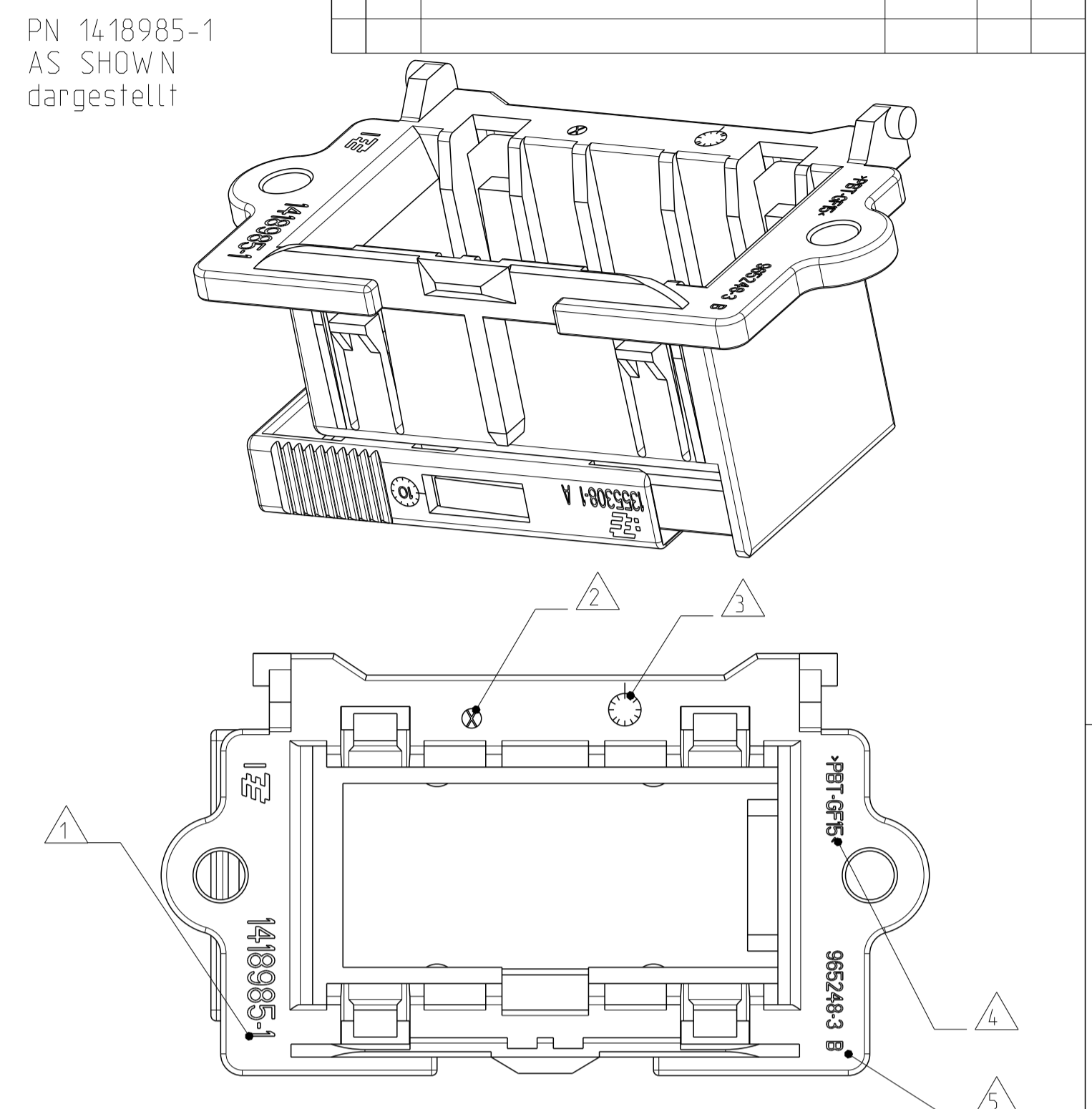
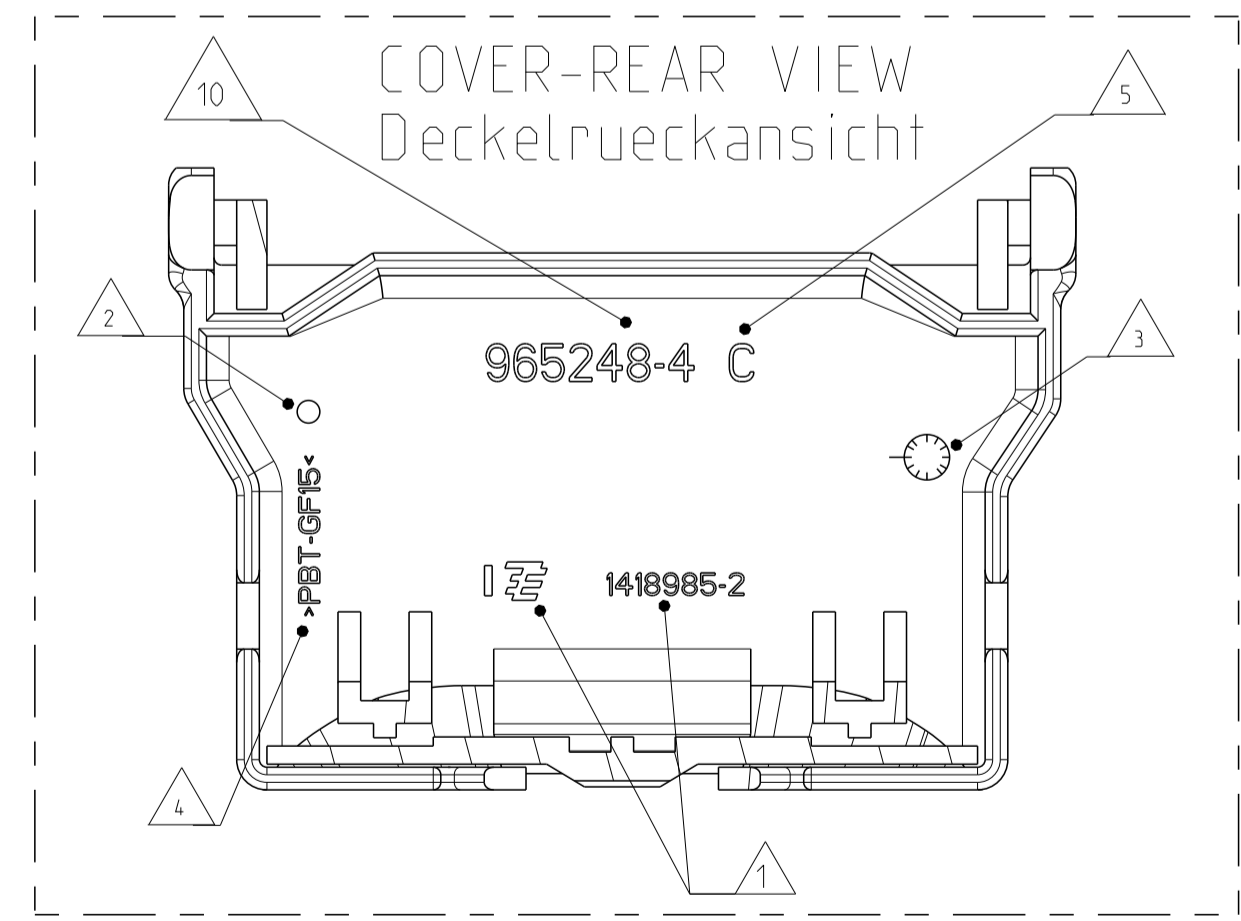
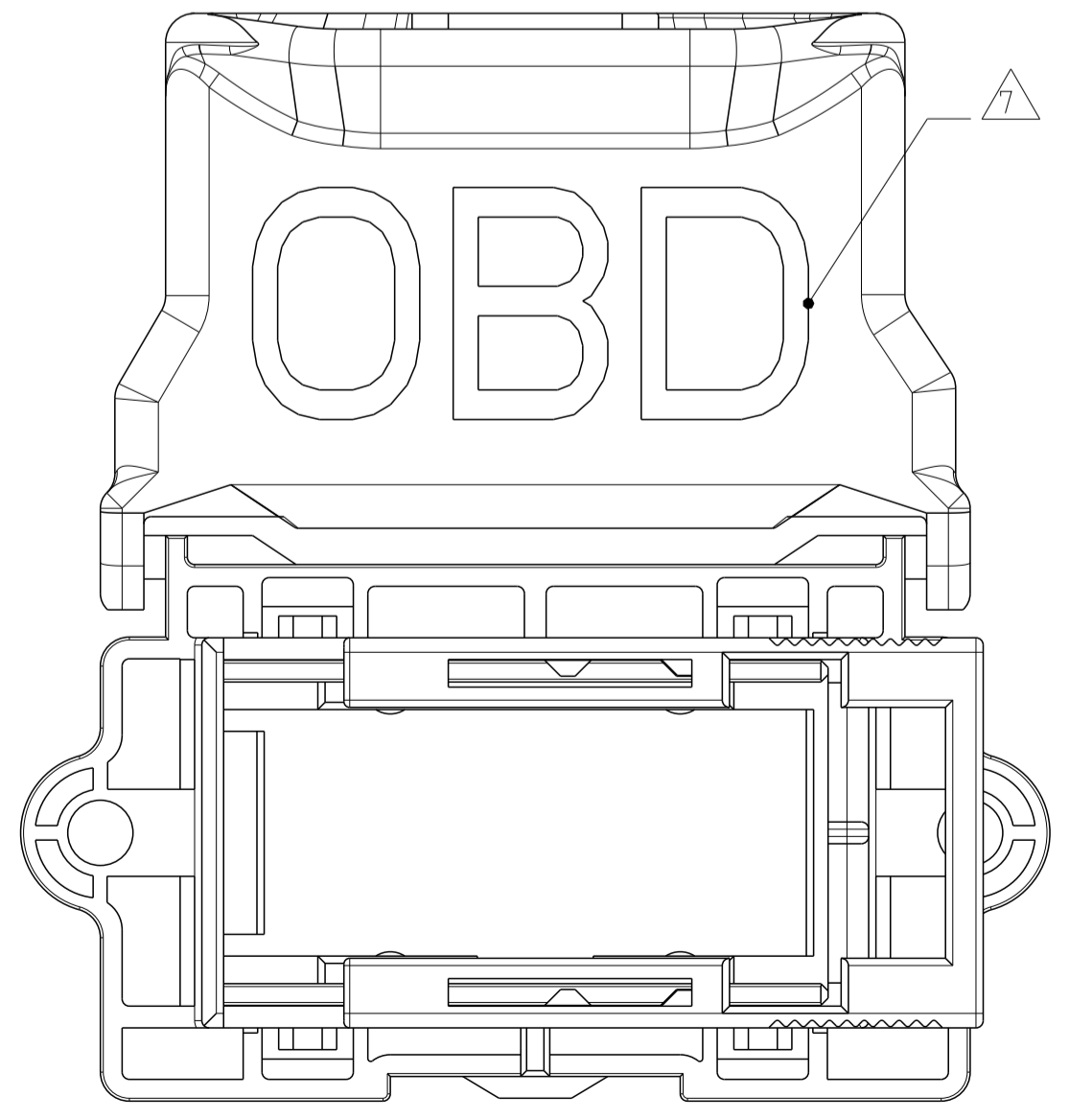

TE ORDER-NO. TE Bestell-Nr.	REV.	WEIGHT (g)	POS.	QTY Stück	MATERIAL	COLOUR Farbe	DESCRIPTION Beschreibung	ITEM
1418985-3	C	22.5	2	1	PBT-GF10	BLACK/schwarz RAL 9011	SLIDE Schieber	3
			1	1	PBT-GF15	BLACK/schwarz RAL 9011	FRAME WITH COVER Halterahmen mit Deckel	
1418985-2	C	22.5	2	1	PBT-GF10	BLACK/schwarz RAL 9011	SLIDE Schieber	2
			1	1	PBT-GF15	BLACK/schwarz RAL 9011	FRAME WITH COVER Halterahmen mit Deckel	
1418985-1	B	15.5	2	1	PBT-GF10	BLACK/schwarz RAL 9011	SLIDE Schieber	1
			1	1	PBT-GF15	BLACK/schwarz RAL 9011	FRAME WITHOUT COVER Halterahmen ohne Deckel	

**PRODUCT FOR BUS AND TRUCK
 MANUFACTURER ONLY !!
 Produkt nur fuer
 Bus und LKW Hersteller !!**

THIS DRAWING IS A CONTROLLED DOCUMENT.
 DIESES ZEICHNUNGSDOKUMENT IST EIN KONTROLLIERTES DOKUMENT.
 ANSCHAUEN SIE SICH DIE VERFAHRENSSCHRIFFTEN FÜR DIE VERFAHRENS-
 UND QUALITÄTSSICHERUNG (VQS) AN DER WERKZEUGFABRIKATION (WZ-FABRIKATION).

DATE: 26MAY2003
 CHK: C. Eberwein
 APVD: -

NAME: FRAME FOR MICRO TIMER3 REC. HOUSING, 16POS.
 Halterahmen fuer Micro Timer3 Buchsengeh.. 16pol.

PRODUCT SPEC: -
 PRODUKTSPEZ.: -

APPLICATION SPEC: -
 VERARBEITUNGSSPEZ.: -

SIZE: A1
 CAGE CODE: -
 DRAWING NO: 1418985
 SCALE: 2:1
 SHEET: 1 OF 1
 REV: C 2

RESTRICTED TO: -
 NUR FÜR: -

CUSTOMER DRAWING /KUNDENZEICHNUNG