



ANATECH ELECTRONICS INC
RF & Microwave Filters & Products

2120 MHz Cavity Band Pass Filter

Part Number: AE2120B6928



Electrical specifications

Center Frequency: 2120 MHz
Bandwidth: 50 MHz
Input / Output Impedance: 50 Ohms
Passband: 2095-2145 MHz
Passband Insertion Loss: <1.0 dB
Passband Ripple: <0.1 dB
Passband Return Loss:
Rejection: >50dB @ 0-1745 MHz
Rejection 2: >50dB @ 2575-5000 MHz
Power Handling: 50 W

Mechanical

Mounting Method: Threaded Mounting Holes
Connector Type: SMA (F)
Dimensions: 2.5" x 1.25" x .625"

Environmental

Operating Temperature: -45 to +85 deg.C
Storage Temperature: -55 to +95 deg.C
Shock: 20 G. 11ms
Vibration: 20 G. 5 to 200 MHz

Outline Drawing:

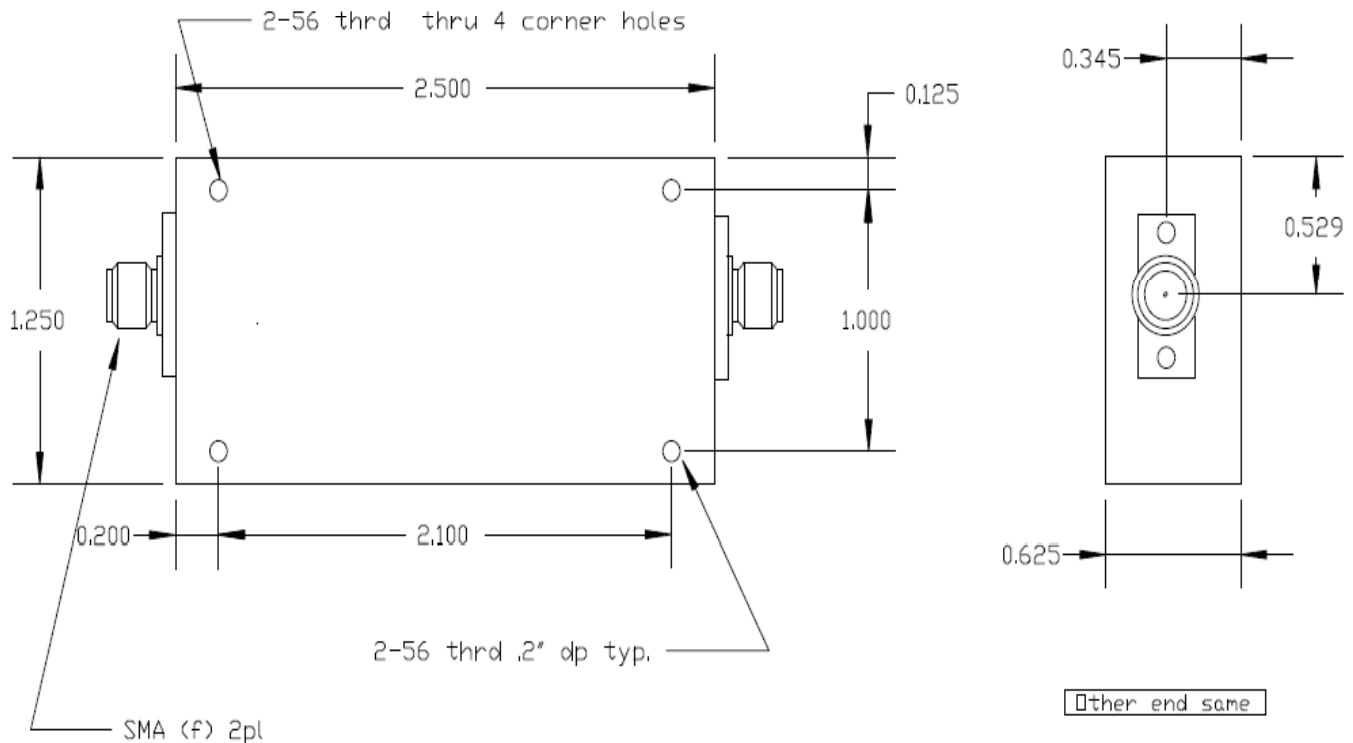



ANATECH ELECTRONICS INC
RF & Microwave Filters & Products

2120 MHz Cavity Band Pass Filter

Part Number: AE2120B6928



Response Plot:

