

## Power line communication expansion board based on ST7580 for STM32 Nucleo

Data brief

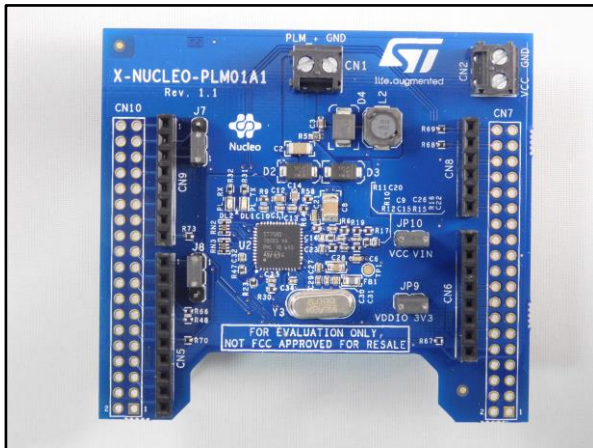

### Description

The X-NUCLEO-PLM01A1 expansion board for STM32 Nucleo is based on the ST7580 FSK, PSK multi-mode power line networking system-on-chip. It provides an affordable and easy-to-use solution for the development of connectivity applications based on power line communication. It lets you easily evaluate the communication features of the ST7580 based on a DC two-wire link between two boards.

You can also perform evaluation on an AC power line by connecting the X-NUCLEO-PLM01A1 to an STEVAL-XPLM01CPL board providing effective AC coupling and isolation. The X-NUCLEO-PLM01A1 is interfaced with the STM32 controller via UART and GPIO pins and is compatible with the Arduino UNO R3 (default configuration) and ST morpho (optional, not mounted) connectors.

### Features

- STM32 Nucleo expansion board based on the ST7580 power line networking system-on-chip
- ST7580 main characteristics:
  - FSK, PSK modem for robust wireline communication up to 28.8 kbps
  - 8-18 V analog supply voltage
  - 3.3 V digital supply
  - Output transmitted signal capability up to 14 V<sub>p-p</sub>, 1 A<sub>rms</sub>
  - Frequency range 9-250 kHz
- TX and RX filters on board optimized for the CENELEC B (95-125 kHz) frequency band, suitable for IoT / Smart Home / Smart City applications
- Compatible with STM32 Nucleo boards
- Equipped with Arduino UNO R3 connectors
- Example firmware available for point-to-point communication, compatible with STM32Cube firmware
- RoHS compliant



# 1 Schematic diagrams

Figure 1: X-NUCLEO-PLM01A1 schematic (1 of 3)

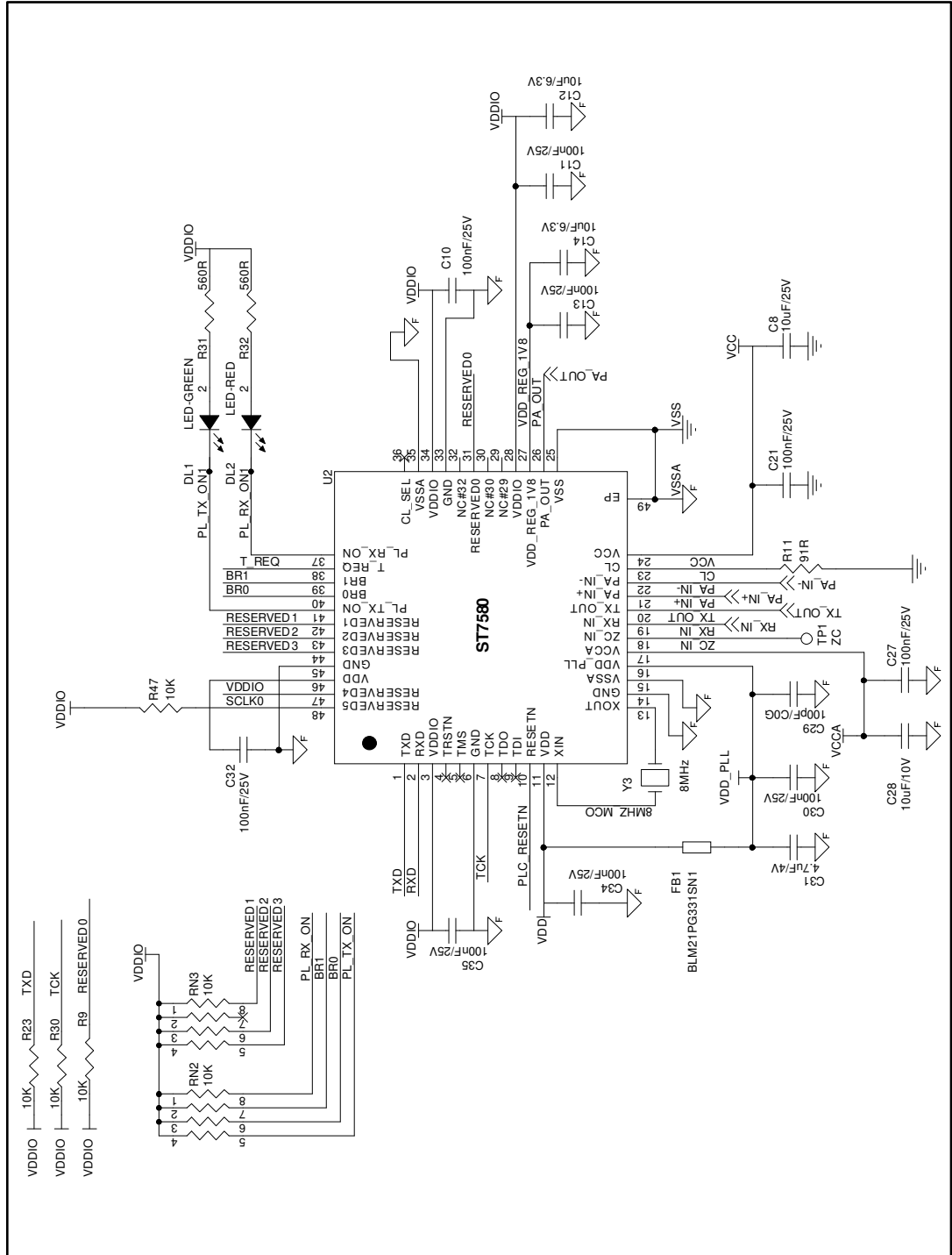

Figure 2: X-NUCLEO-PLM01A1 schematic (2 of 3)

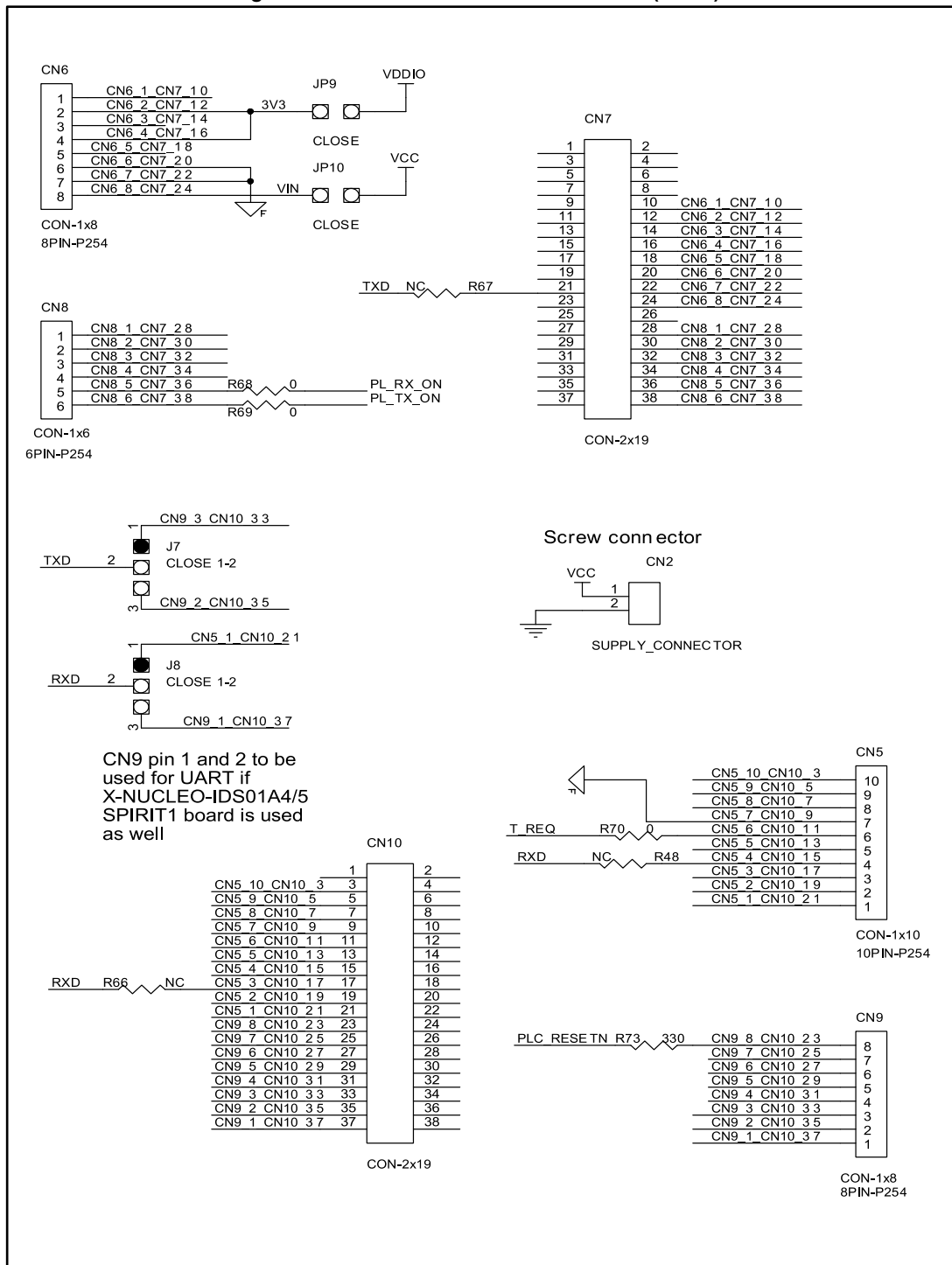
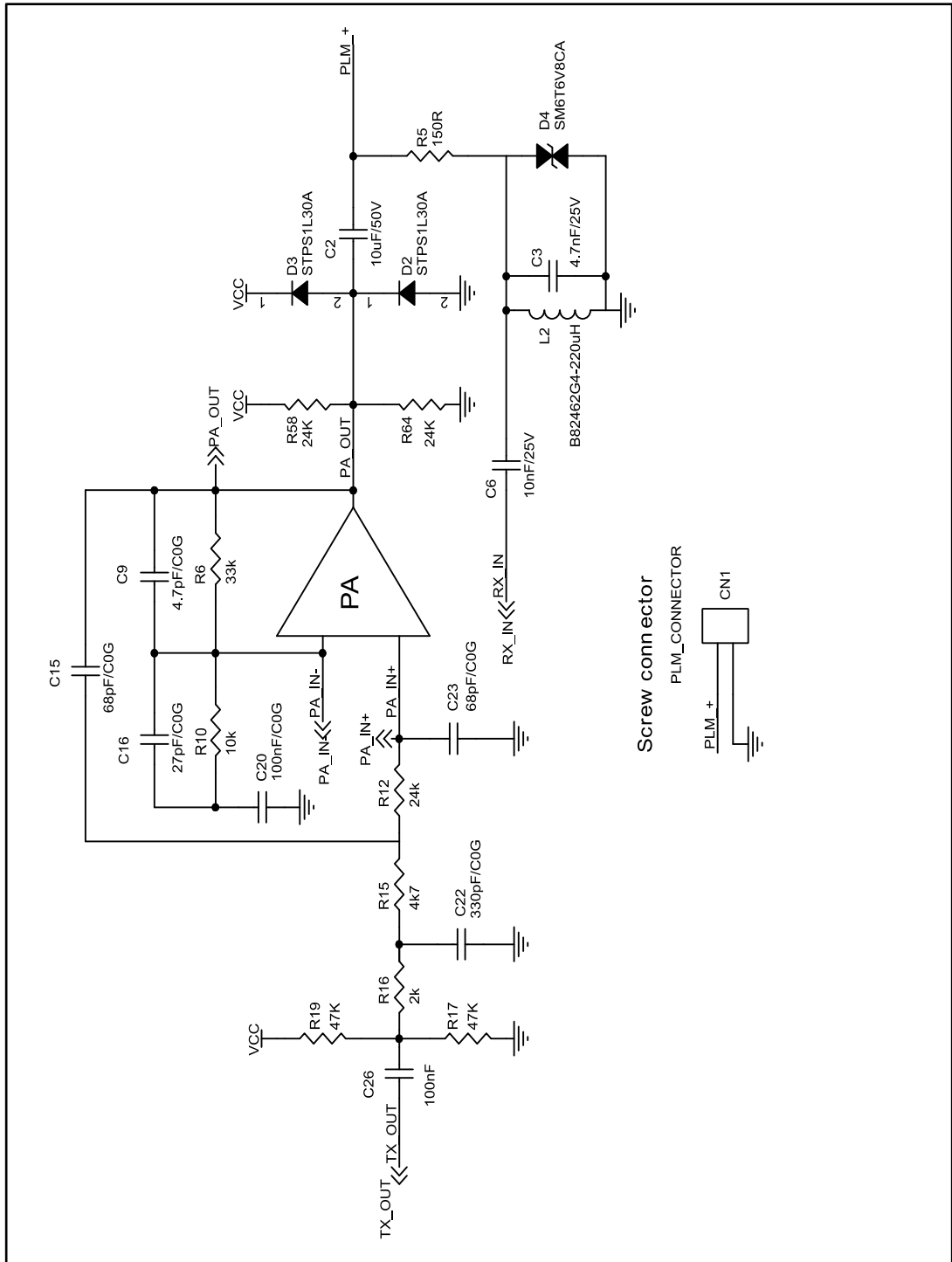

Figure 3: X-NUCLEO-PLM01A1 schematic (3 of 3)



## 2 Revision history

Table 1: Document revision history

Date	Version	Changes
14-Jun-2017	1	Initial release.

**IMPORTANT NOTICE – PLEASE READ CAREFULLY**

STMicroelectronics NV and its subsidiaries ("ST") reserve the right to make changes, corrections, enhancements, modifications, and improvements to ST products and/or to this document at any time without notice. Purchasers should obtain the latest relevant information on ST products before placing orders. ST products are sold pursuant to ST's terms and conditions of sale in place at the time of order acknowledgement.

Purchasers are solely responsible for the choice, selection, and use of ST products and ST assumes no liability for application assistance or the design of Purchasers' products.

No license, express or implied, to any intellectual property right is granted by ST herein.

Resale of ST products with provisions different from the information set forth herein shall void any warranty granted by ST for such product.

ST and the ST logo are trademarks of ST. All other product or service names are the property of their respective owners.

Information in this document supersedes and replaces information previously supplied in any prior versions of this document.

© 2017 STMicroelectronics – All rights reserved