

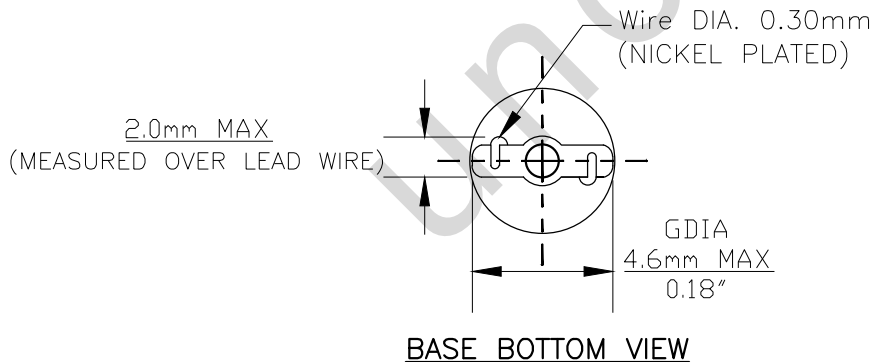

PART NO.	BASE TYPE	DESIGN VOLTS	DESIGN AMPS	MSCD	FILAMENT TYPE	AVERAGE LIFE HOURS	REVISIONS			
							REV #	DESCRIPTION	DATE	APPROVED
2721	Glass Wedge W2X4.6d (T-1 1/2)	12.0V	0.1±15%	0.48±30%	C-2V	1000	1	ISSUED	10/30/2008	D.C.
							2	REDRAWN, ADDED 90° VIEW, REVISED DIMENSIONS	06/30/2014	R.M.
							3	REVISED AMPS	04/03/2020	R.M.

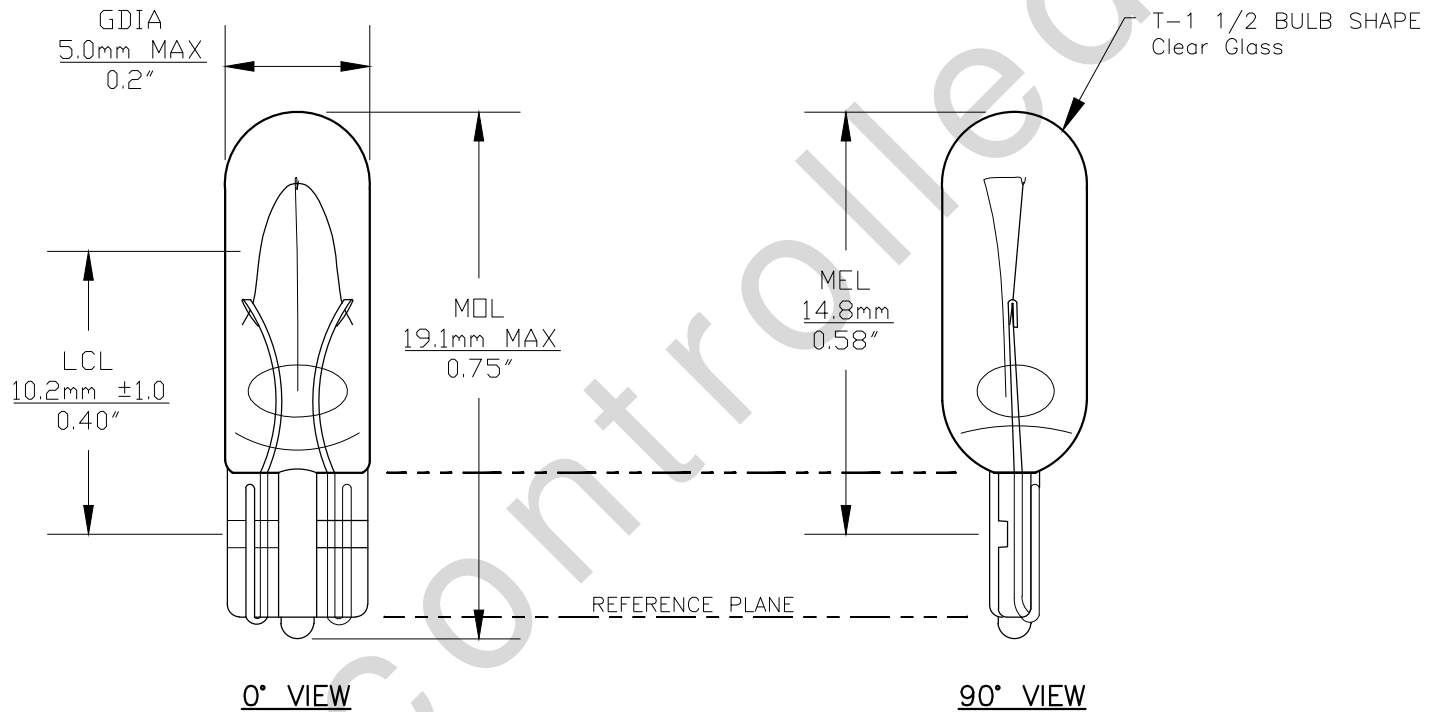

Note: Made according to SAE specifications



UNLESS OTHERWISE SPECIFIED: DIMENSIONS ARE IN INCHES TOLERANCES		CEC INDUSTRIES LTD	
DECIMALS	ANGULAR	599 BOND STREET LINCOLNSHIRE, IL 60069	
.XX ± .05	± 0.5°		
.XXX ± .010			
FRACTIONAL	± 1/64		
DRAWN D.C.	DATE 10/30/2008	TITLE LIGHT BULB NO. 2721	
CHECKED	SIZE A	FSCM NO.	DWG NO. 2721 REV 3
DESIGN	SCALE	PLOT SCALE	SHEET 1 OF 1
MATERIAL	FILE 2721.pdf	DRAWING NOT TO SCALE	