



SURE-SEAL UNIVERSAL BACKSHELL & CG ADAPTERS



Table of Contents

How to use a Backshell, Recipe Guide	4
Universal Backshell	
Commercial MIL-DTL 5015 - AIB/AIT.....	10
Commercial MIL-DTL 5015 - CB/CT	11
Commercial MIL-DTL 5015 - MS345	12
Commercial MIL-DTL 26482 - Series I.....	13
Commercial MIL-DTL 26482 - Series II	14
Commercial MIL-DTL D38999 - Series I	15
Commercial MIL-DTL D38999 - Series II.....	16
Commercial MIL-DTL D38999 - Series III.....	17
CG Adapter	
Commercial MIL-DTL 5015 - AIB/AIT.....	18
Commercial MIL-DTL 5015 - CB/CT	19
Commercial MIL-DTL 5015 - MS345	20
Commercial MIL-DTL 26482 - Series I.....	21
Commercial MIL-DTL 26482 - Series II.....	22
Commercial MIL-DTL D38999 - Series I	23
Commercial MIL-DTL D38999 - Series II	24
Commercial MIL-DTL D38999 - Series III	25
Mod Codes & Accessories	26

DISCLAIMER -

Sure-Seal Connections's range of Universal Backshell and CG Adapter solutions have been thoroughly tested and certified when used with both Amphenol and ITT Cannon connector solutions, for guaranteed inter-mateable performance with other connector manufacturers including but not limited to: Deutsch, Souriau, Conesys & Cinch. - Please contact your local PEI-Genesis representative.

PEI-Genesis cannot be held liable for inter-mateable performance with 3rd party manufacturers.

Notes

Instructions are for reference only, please refer to PEI-Genesis's [Cookbook](#) for further information.

How to use our backshells

After more than 70 years of experience our application engineers have answered thousands of technical inquiries, and the most common questions always involve ways to design or build cable assemblies.

When we consider how long it often takes our customers to investigate potential parts, get samples, build prototypes, test designs, calculate costs, create drawings and transfer it to production it was amazing how large a simple cable assembly project could become.

Simplify the design

After evaluating hundreds of designs, we set out to create a mass-customized approach for building typical cable assemblies. This leads to the eight basic “Cookbook” design approaches we call our “A to H Menus”. These eight approaches address the vast majority of the design challenges you will face.

Menu Type	Cable Design Recipes	Repairability		Grounding & Shielding		Fluid Protection		Cable Types		
		Tamper Resistant	Field Serviceable	EMI/RFI Shielded (Screened)	Earth Ground to Shell	Environmentally Sealed	Self Draining	Single Jacketed Cable or Single Jacketed Wire	Multiple Wires or Cables	Non-Standard Mix of Wire Sizes
A	Unshielded with Heat Shrink Boot or Tubing									
B	EMI/RFI Shielded with Heat Shrink Boot or Tubing									
C	Grounded with Heat Shrink Boot or Tubing									
D	Conduit with Heat Shrink Boot or Tubing									
E	Expando Braided Sleeve Protection									
F	Unshielded with Cord Grip									
G	EMI/RFI Shielded with Cord Grip									
H	Sealed Flexible Conduit									

Notes

Instructions are for reference only, please refer to PEI-Genesis’s [Cookbook](#) for further information.

Definitions

<p>Repairability</p>	 <p>Tamper Resistant: The assemblies cannot be taken apart and reworked. If the cable assembly is damaged in the field it needs to be replaced.</p>  <p>Field Service: The connector and endbell can be disassembled allowing users to remove contacts and re-wire the assembly.</p>	<p>PEI Advice: There are three questions we usually ask.</p> <ol style="list-style-type: none"> 1. Could a mis-wired field repair result in damage to the electronic system or lead to other safety or system problems? 2. Does your warranty depend on the integrity of the cable assembly? 3. Is there potential for you to sell spare or replacement cables as an accessory? If the answer to any of these is yes, then we recommend using a tamper resistant design.
<p>Grounding & Shielding</p>	 <p>EMI/RFI Shielded (Screened): High frequency electronic noise can either be radiated out or absorbed into a cable assembly. Shielding is a conductive layer that prevents noise from either getting in or escaping. A key issue for cable assemblies is the coverage between the cable and the connector. In our Shielded designs we use 360 degree coverage going from the shield in the cable to the connector shell and endbell. This is suitable for low, medium or high frequency applications.</p>  <p>Earth Ground to Shell: Cable assemblies that carry power often need to have all conductive surfaces grounded to the cable shield as a safety feature. In these designs metal shell connectors and endbells need to be connected to the shield of the cable. This shield also has to be able to exceed the fuse rating for the power circuit. Grounded cables should use braided shielding and bayonet style plug connectors should use grounding fingered barrels. Foil shielding usually cannot handle the current load.</p>	<p>PEI Advice: It is possible for a cable assembly to be both grounded and shielded. Our grounded assembly designs (Menus C and D) provide shielding suitable for low to medium frequency applications (<50 MHz). At these frequencies the gap between the endbell and the cable is small enough that electro-magnetic noise isn't likely to pass.</p> <p>At higher frequencies we recommend adding the 360 degree protection in our shielded designs (Menus B and G). Remember – shielding protects both outgoing and incoming noise. When selecting the upper shielding protection range it is important to consider both.</p>
<p>Fluid Protection</p>	 <p>Environmentally Sealed: In these designs the connector, endbell and wire protection (or cable jacket) work together to prevent water or other fluids from penetrating inside of the assembly.</p>  <p>Self Draining: These assemblies seal the rear of the connector where the wire or cable enters the endbell. If water gets inside of the wire protection it cannot easily penetrate into the connector. The self draining feature allows the water to get back out so it does not build up inside of the wire protection.</p>	<p>PEI Advice: Environmentally sealed designs using jacketed cables or plastic conduit are more commonly used for harsh environment applications. Self draining designs can offer advantages in cost, weight or flexibility if some durability can be conceded.</p>
<p>Cable Types</p>	 <p>Single Jacketed Cable: These are cables with multiple conductors on the inside and an outside jacketing (usually PVC or Polyurethane) to protect the wires.</p>  <p>Multiple Wires or Cables: These are designs where several individual wires or cables are bundled together.</p>  <p>Non-Standard Mix of Wire Sizes: These are assemblies that use a wide mix of wires, cables, hoses, etc. They pose a challenge because of the different sizes and protection needs.</p>	<p>PEI Advice: Single Jacketed Cables will work with any of our design platforms. Menus A, B, C, F and G work very well with these. Conduit and Expando are great options for Multiple Wires or for a Non-Standard Mix. Flexible conduit (Menus D and H) is recommended for harsh environment and heavy duty applications. It is a great alternative to custom jacketed cables since it can be assembled from off the shelf materials. Expando (Menu E) is recommended for less demanding applications where bundling is needed.</p>

Notes

Instructions are for reference only, please refer to PEI-Genesis's [Cookbook](#) for further information.

A



Unshielded with Heat Shrink Boot or Tubing

All that is needed is a PEI-Genesis MIL-Style Connector, the correct Sure-Seal Universal Backshell and an appropriately sized heat shrink tube.

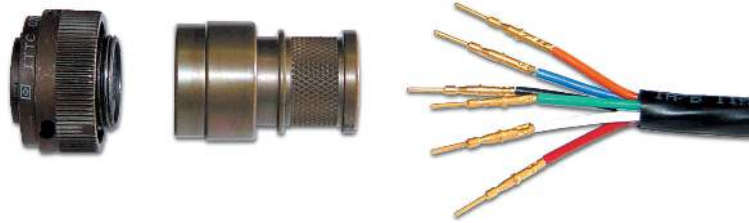

Once the contacts are installed, fully screw down the Backshell and heat shrink the tubing in place. Starting from the connector working your way down the cable.



B



EMI/RFI Shielded with Heat Shrink Boot or Tubing

To terminate EMI/RFI shielded cables to our range of backshells, all you need is a constant force spring band and a short length of shielding tape.

Spread the cable shield over the rear of the backshell and lock tightly into position using the spring band.



Afterwards wrap the band and rear of the backshell with shielding tape, and cover using an appropriately sized heat shrink boot or tubing.

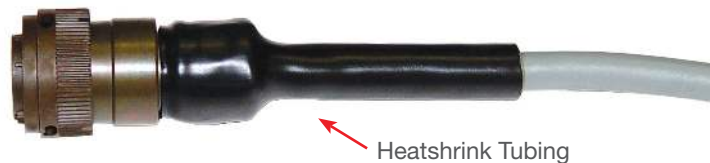

Notes

Instructions are for reference only, please refer to PEI-Genesis's [Cookbook](#) for further information.

C

Grounded with Heat Shrink Boot or Tubing

Some cables do not come with a full braided shield, and come with a set of foil pairs and a drain wire. In this instance as per Menu B - wrap the drain wire to the backshell with a constant force spring band.

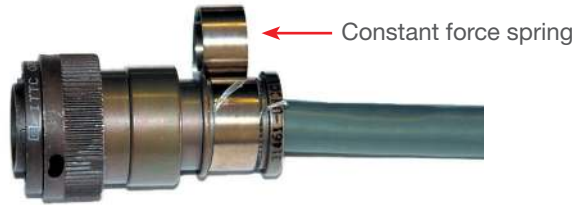

Afterwards wrap the band and the exposed inner cable with shielding tape, ensuring that the tape has evenly covered the rear of the backshell and no gaps are visible.



Then cover using an appropriately sized heat shrink boot or tubing.



D

Conduit with Heat Shrink Boot or Tubing

Sure-Seal's Universal Backshell also makes it easy to attach conduit to your cable assembly. Simply slide the conduit inside the backshell, attaching any drain wires to the backshell if required using a constant force spring.



Once you are happy with the position of the conduit, then cover with an appropriately sized heat shrink tube to lock into place.

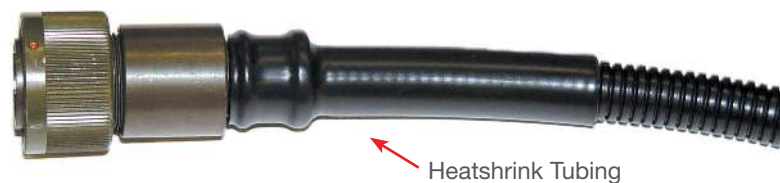

Notes

Instructions are for reference only, please refer to PEI-Genesis's [Cookbook](#) for further information.

E

-
-
-
-
-
-

Expando Braided Sleeve Protection



A low cost but professional looking way to protect individual wires is to use Expando Sleeve. By opening the sleeving over a fully terminated connector and securing into place via a constant force spring, you can then flip the sleeving giving a secure and professional finish.



F

-
-
-
-
-

Unshielded with Cord Grip

Using Sure-Seal's CG Adapter, it is easy to convert your connector threads ready for simple termination to accessories. Once your connector is fully terminated, slide the CG adapter into place and screw firmly into your connector.



Using an appropriately sized Cord Grip matching your cable diameter, simply screw that into your CG Adapter.



Notes

Instructions are for reference only, please refer to PEI-Genesis's [Cookbook](#) for further information.

G



EMI/RFI Shielded with Cord Grip

Using Sure-Seal's CG Adapter, it is easy to convert your connector threads ready for simple termination to accessories.

Once your connector is fully terminated, slide the CG adapter into place and screw firmly into your connector.



Using an appropriately sized Cord Grip matching your cable diameter, simply screw that into your CG Adapter.



H



Sealed Flexible Conduit

Using Sure-Seal's CG Adapter, it is easy to convert your connector threads ready for simple termination to accessories.

Once your connector is fully terminated, slide the CG adapter into place and screw firmly into your connector.

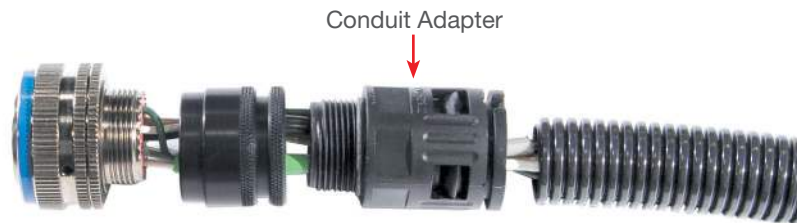

Using an appropriately sized conduit adapter matching your conduit size, simply screw that into your CG Adapter.



Notes

Instructions are for reference only, please refer to PEI-Genesis's [Cookbook](#) for further information.

Universal Backshell, Commercial Grade MIL-DTL 5015, Straight (AIT/AIB)

Connector Series: MIL-DTL 5015 (Commercial Grade)
 Suitable With: Amphenol AIT, AIB
 Style: Banding Backshell, w/ O-ring
 Direction: Straight
 Part No.: IP-U*XXXX#

* Refers to Backshell Material
 # Refers to Plating Code
 XXXX Refers to Backshell Style & Connector Shell Size (See table below)

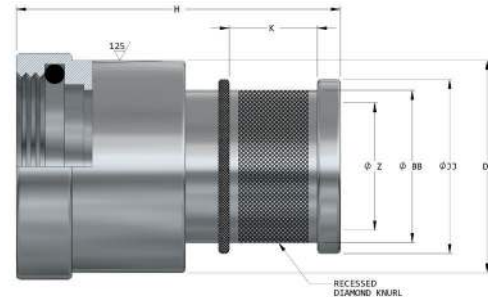

Material & Plating Information

IP-U*XXXX#

Material Code	Description	Material Code	Description
N	Aluminium	S4	Stainless Steel 304
S	Stainless Steel 303	S6	Stainless Steel 316

Plating Code	Description	Conductive	ROHS	Salt Spray
A	Black Anodize, Sulphuric, Per MIL-A-8625, Type II, Class 2	N	Y	336
B	Black Zinc Cobalt, Per ASTM B840-99, Grade 661, Type 0, Over Electroless Nickel	Y	Y	350
G	Green Zinc Cobalt, Per ASTM B840-99, Grade 6, Over Electroless Nickel	Y	Y	350
N	Electroless Nickel, per MIL-C-26074 Class 4, Grade (0.0010" Min)	Y	Y	96
P	Passivated (Stainless Steel) SAE-AMS-00-P-35 Type V)	Y	Y	1000
W	Cadmium Olive Drab Per QQ-P-416, Type II, Class 3, over Electroless Nickel. Per MIL-C-26074, Class 3/4, Grade B	Y	N	500
ZG	Zinc Gray Nickel, Per ASTM-B84a	Y	Y	500
ZN	Zinc Nickel Black Passivate (5-12 Microns) Over Electroless Nickel (8-12 Microns), ASTM B 841 Class 1	Y	Y	500

Product Dimensions

Part No.:	Shell Size	H Max	DØ	K Max	ZØ Cable Max	BBØ Max	JJØ Max
IP-U*CB8#	8S	See factory for information					
IP-U*CB10#	10SL	1.500 (38.1)	0.740 (18.8)	0.375 (9.52)	0.372 (9.4)	0.493 (12.5)	0.588 (14.9)
IP-U*CB12#	12/12S	1.500 (38.1)	0.740 (18.8)	0.375 (9.52)	0.413 (10.50)	0.493 (12.5)	0.587 (14.92)
IP-U*CB14#	14/14S	1.587 (40.3)	0.990 (25.1)	0.375 (9.52)	0.531 (13.49)	0.665 (16.9)	0.783 (19.9)
IP-U*CB16S#	16S	1.709 (43.4)	0.990 (25.1)	0.375 (9.52)	0.703 (17.86)	0.807 (20.5)	0.926 (23.5)
IP-U*CB16#	16	1.709 (43.4)	0.990 (25.1)	0.375 (9.52)	0.703 (17.86)	0.807 (20.5)	0.926 (23.5)
IP-U*CB18#	18	1.752 (44.5)	1.146 (29.1)	0.375 (9.52)	0.687(17.46)	0.821 (20.86)	0.939 (23.86)
IP-U*CB20#	20	1.760 (44.7)	1.271 (32.3)	0.375 (9.52)	0.750 (19.04)	0.891 (22.6)	1.010 (25.6)
IP-U*CB22#	22	1.780 (45.2)	1.271 (32.3)	0.375 (9.52)	0.813 (20.64)	0.954 (24.2)	1.072 (27.2)
IP-U*CB24#	24	1.933 (49.1)	1.552 (39.4)	0.375 (9.52)	0.938 (23.81)	1.094 (27.8)	1.213 (30.8)
IP-U*CB28#	28	2.150 (54.6)	1.552 (39.5)	0.375 (9.52)	0.937 (23.81)	1.095 (27.8)	1.213 (30.8)
IP-U*CB32#	32	2.244 (57.0)	1.772 (45.0)	0.375 (9.52)	1.125 (31.75)	1.407 (35.7)	1.526 (38.7)
IP-U*CB36#	36	2.449 (62.2)	2.043 (51.9)	0.375 (9.52)	1.375 (34.92)	1.532 (38.92)	1.651 (41.92)
IP-U*CB40#	40	2.860 (72.6)	2.291 (58.2)	0.375 (9.52)	1.625 (41.28)	1.782 (45.28)	1.901 (48.28)

Dimensions in Inches ± .008 (Millimetres in brackets)

Notes

- Additional plating and materials are available upon request.
- "P" Plating is only applicable when a stainless base material is selected.
- Universal Backshell does not accommodate factory supplied wire sealing grommet or ferrule.

Universal Backshell, Commercial Grade MIL-DTL 5015, Straight (CT/CB)

Connector Series: MIL-DTL 5015 (Commercial Grade)
 Suitable With: Cannon CT, CB
 Style: Banding Backshell, w/ O-ring
 Direction: Straight
 Part No.: IP-U*XXXX#

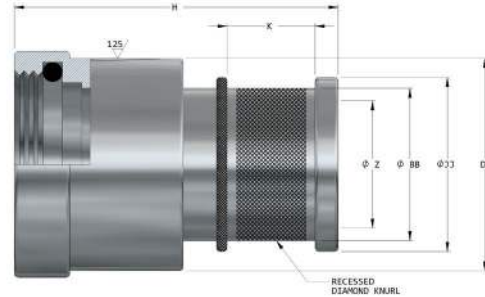

* Refers to Backshell Material
 # Refers to Plating Code
 XXXX Refers to Backshell Style & Connector Shell Size (See table below)

Material & Plating Information

IP-U*XXXX#

Material Code	Description	Material Code	Description
N	Aluminium	S4	Stainless Steel 304
S	Stainless Steel 303	S6	Stainless Steel 316

Plating Code	Description	Conductive	ROHS	Salt Spray
A	Black Anodize, Sulphuric, Per MIL-A-8625, Type II, Class 2	N	Y	336
B	Black Zinc Cobalt, Per ASTM B840-99, Grade 661, Type 0, Over Electroless Nickel	Y	Y	350
G	Green Zinc Cobalt, Per ASTM B840-99, Grade 6, Over Electroless Nickel	Y	Y	350
N	Electroless Nickel, per MIL-C-26074 Class 4, Grade (0.0010" Min)	Y	Y	96
P	Passivated (Stainless Steel) SAE-AMS-00-P-35 Type V)	Y	Y	1000
W	Cadmium Olive Drab Per QQ-P-416, Type II, Class 3, over Electroless Nickel. Per MIL-C-26074, Class 3/4, Grade B	Y	N	500
ZN	Zinc Nickel Black Passivate (5-12 Microns) Over Electroless Nickel (8-12 Microns), ASTM B 841 Class 1	Y	Y	500

Product Dimensions

Part No.:	Shell Size	H Max	DØ	K Max	ZØ Cable Max	BBØ Max	JJØ Max
IP-U*CC8#	8S	1.306 (33.2)	0.740 (18.8)	.740 (18.80)	0.312 (7.94)	0.391 (9.9)	0.486 (12.3)
IP-U*CA10#	10SL	1.405 (35.68)	0.74 (18.8)	0.375 (9.52)	.390 (9.9)	0.493 (12.52)	0.588 (14.92)
IP-U*CA12#	12/12S	1.491 (37.88)	0.74 (18.79)	0.375 (9.52)	0.375 (9.52)	0.493 (12.52)	0.588 (14.92)
IP-U*CA14#	14/14S	1.527 (38.79)	0.865 (21.96)	0.375 (9.52)	0.531 (13.49)	0.665 (16.89)	0.783 (19.89)
IP-U*CA16#	16	1.693 (42.99)	0.990 (25.14)	0.375 (9.52)	0.641 (16.27)	0.807 (20.51)	0.926 (23.51)
IP-U*CA16S#	16S	1.547 (39.29)	0.990 (25.14)	0.375 (9.52)	0.641 (16.27)	0.807 (20.51)	0.926 (23.51)
IP-U*CA18#	18	1.842 (46.79)	1.146 (29.11)	0.375 (9.52)	0.687 (17.46)	0.821 (20.86)	0.939 (23.86)
IP-U*CA20#	20	1.881 (47.79)	1.271 (32.29)	0.375 (9.52)	0.750 (19.04)	0.891 (22.64)	1.010 (25.64)
IP-U*CA22#	22	1.870 (47.49)	1.428 (36.26)	0.375 (9.52)	0.812 (20.64)	0.954 (24.24)	1.072 (27.24)
IP-U*CA24#	24	1.822 (46.29)	1.552 (39.43)	0.375 (9.52)	0.937 (23.81)	1.095 (27.81)	1.213 (30.81)
IP-U*SA28#	28	1.980 (50.29)	1.522(39.43)	0.375 (9.52)	0.937 (23.80)	1.095 (27.81)	1.213 (30.81)
IP-U*SA32#	32	2.452 (62.29)	1.799 (45.70)	0.375 (9.52)	0.937 (23.80)	1.095 (27.81)	1.095 (27.81)
IP-U*SA36#	36	2.449 (62.20)	2.291 (58.20)	0.375 (9.52)	1.375 (34.92)	1.532 (38.92)	1.650 (41.92)

Dimensions in Inches ± .008 (Millimetres in brackets)

Notes

- Additional plating and materials are available upon request.
- "P" Plating is only applicable when a stainless base material is selected.
- Universal Backshell does not accommodate factory supplied wire sealing grommet or ferrule.

Universal Backshell, Commercial Grade MIL-DTL 5015, Straight (MS345)

Connector Series: MIL-DTL 5015 (Commercial Grade)
 Suitable With: Crimp MS345 Rear Release
 Style: Banding Backshell, w/ O-ring
 Direction: Straight
 Part No.: IP-U*XXXX#

* Refers to Backshell Material
 # Refers to Plating Code
 XXXX Refers to Backshell Style & Connector Shell Size (See table below)

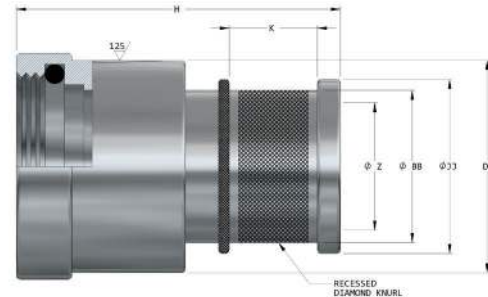

Material & Plating Information



Material Code	Description	Material Code	Description
N	Aluminium	S4	Stainless Steel 304
S	Stainless Steel 303	S6	Stainless Steel 316

Plating Code	Description	Conductive	ROHS	Salt Spray
A	Black Anodize, Sulphuric, Per MIL-A-8625, Type II, Class 2	N	Y	336
B	Black Zinc Cobalt, Per ASTM B840-99, Grade 661, Type 0, Over Electroless Nickel	Y	Y	350
N	Electroless Nickel, per MIL-C-26074 Class 4, Grade (0.0010" Min)	Y	Y	96
P	Passivated (Stainless Steel) SAE-AMS-00-P-35 Type V)	Y	Y	1000
W	Cadmium Olive Drab Per QQ-P-416, Type II, Class 3, over Electroless Nickel. Per MIL-C-26074, Class 3/4, Grade B	Y	N	500
ZN	Zinc Nickel Black Passivate (5-12 Microns) Over Electroless Nickel (8-12 Microns), ASTM B 841 Class 1	Y	Y	500

Product Dimensions

Part No.:	Shell Size	H Max	DØ	K Max	ZØ Cable Max	BBØ Max	JJØ Max
IP-U*CA12#	10	1.491 (37.88)	0.74 (18.79)	0.375 (9.52)	0.375 (9.52)	0.493 (12.52)	0.588 (14.92)
IP-U*CA14#	12	1.527 (38.79)	0.865 (21.96)	0.375 (9.52)	0.531 (13.49)	0.665 (16.89)	0.783 (19.89)
IP-U*CA16#	14	1.693 (42.99)	0.990 (25.14)	0.375 (9.52)	0.641 (16.27)	0.807 (20.51)	0.926 (23.51)
IP-U*CA18#	16	1.842 (46.79)	1.146 (29.11)	0.375 (9.52)	0.687 (17.46)	0.821 (20.86)	0.939 (23.86)
IP-U*CH18#	18	1.654 (42.0)	1.271 (32.29)	0.375 (9.52)	0.750 (19.04)	0.891 (22.64)	1.010 (25.64)
IP-U*CH20#	20	1.693 (43.0)	1.428 (36.26)	0.375 (9.52)	0.813 (20.64)	0.954 (24.24)	1.072 (27.24)
IP-U*CH22#	22	1.811 (46.00)	1.552 (39.43)	0.375 (9.52)	0.937 (23.81)	1.095 (27.81)	1.213 (30.81)
IP-U*CH24#	24	1.811 (46.00)	1.552 (39.43)	0.375 (9.52)	1.00 (25.40)	1.157 (29.40)	1.276 (32.40)

Dimensions in Inches ± .008 (Millimetres in brackets)

Notes

- Additional plating and materials are available upon request.
- "P" Plating is only applicable when a stainless base material is selected.
- Universal Backshell does not accommodate factory supplied wire sealing grommet or ferrule.

Universal Backshell, Commercial Grade MIL-DTL 26482, Straight (Series 1)

Connector Series: MIL-DTL 26482 (Commercial Grade)
Suitable With: 26482 Series 1, MS311#, MS312#,
62GB, PT/PTSE, KPT/KPSE, Souriau 851.

Style: Banding Backshell, w/ O-ring

Direction: Straight

Part No.: IP-U*XXXX#

* Refers to Backshell Material

Refers to Plating Code

XXXX Refers to Backshell Style & Connector Shell Size (See table below)

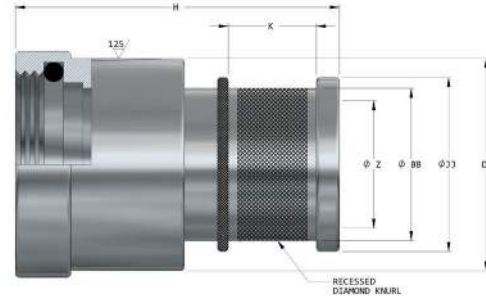

Material & Plating Information

IP-U*XXXX#

Material Code	Description	Material Code	Description
N	Aluminium	S4	Stainless Steel 304
S	Stainless Steel 303	S6	Stainless Steel 316

Plating Code	Description	Conductive	ROHS	Salt Spray
A	Black Anodize, Sulphuric, Per MIL-A-8625, Type II, Class 2	N	Y	336
B	Black Zinc Cobalt, Per ASTM B840-99, Grade 661, Type 0, Over Electroless Nickel	Y	Y	350
G	Green Zinc Cobalt, Per ASTM B840-99, Grade 6, Over Electroless Nickel	Y	Y	350
N	Electroless Nickel, per MIL-C-26074 Class 4, Grade (0.0010" Min)	Y	Y	96
P	Passivated (Stainless Steel) SAE-AMS-00-P-35 Type V)	Y	Y	1000
W	Cadmium Olive Drab Per QQ-P-416, Type II, Class 3, over Electroless Nickel. Per MIL-C-26074, Class 3/4, Grade B	Y	N	500
ZG	Zinc Gray Nickel, Per ASTM-B841	Y	Y	500
ZN	Zinc Nickel Black Passivate (5-12 Microns) Over Electroless Nickel (8-12 Microns), ASTM B 841 Class 1	Y	Y	500

Product Dimensions

Part No.:	Shell Size	H Max	DØ	K Max	ZØ Cable Max	BBØ Max	JJØ Max
IP-U*CC8#	8	1.306 (33.2)	0.740 (18.8)	0.375 (9.52)	.312 (7.94)	0.391 (9.9)	0.486 (12.3)
IP-U*CC10#	10	1.382 (35.1)	0.74 (18.8)	0.375 (9.52)	.375 (9.52)	0.493 (12.5)	0.588 (14.9)
IP-U*CC12#	12	1.397 (35.5)	0.865 (21.97)	0.375 (9.52)	0.562 (14.29)	0.665 (16.9)	0.783 (19.9)
IP-U*CC14#	14	1.507 (38.3)	0.990 (25.1)	0.375 (9.52)	0.625 (15.87)	0.744 (18.9)	0.862 (21.9)
IP-U*CC16#	16	1.575 (40.0)	1.146 (29.1)	0.375 (9.52)	0.687 (17.46)	0.821 (20.86)	0.939 (23.86)
IP-U*CC18#	18	1.654 (42.0)	1.271 (32.29)	0.375 (9.52)	0.750 (19.04)	0.891 (22.64)	1.01 (25.64)
IP-U*CC20#	20	1.693 (43)	1.428 (36.26)	0.375 (9.52)	0.812 (20.64)	0.954 (24.24)	1.072 (27.24)
IP-U*CC22#	22	1.811 (46)	1.552 (39.43)	0.375 (9.52)	0.937 (23.81)	1.095 (27.81)	1.213 (30.81)
IP-U*CC24#	24	1.811 (46)	1.552 (39.43)	0.375 (9.52)	1.00 (25.40)	1.157 (29.40)	1.276 (32.40)

Dimensions in Inches ± .008 (Millimetres in brackets)

Notes

- Additional plating and materials are available upon request.
- "P" Plating is only applicable when a stainless base material is selected.

Universal Backshell, Commercial Grade MIL-DTL 26482, Straight (Series 2)

Connector Series: MIL-DTL 26482 (Commercial Grade)
 Suitable With: 26482 Series 2 (MS347_)
 Style: Banding Backshell, w/ O-ring
 Direction: Straight
 Part No.: IP-U*XXXX#

* Refers to Backshell Material
 # Refers to Plating Code
 XXXX Refers to Backshell Style & Connector Shell Size (See table below)

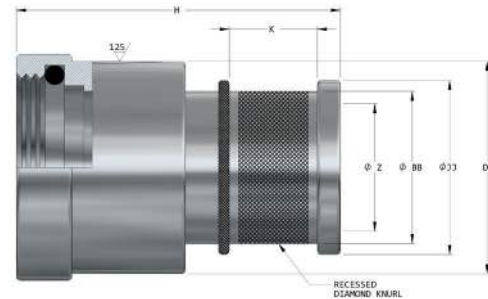

Material & Plating Information



Material Code	Description	Material Code	Description
N	Aluminium	S4	Stainless Steel 304
S	Stainless Steel 303	S6	Stainless Steel 316

Plating Code	Description	Conductive	ROHS	Salt Spray
A	Black Anodize, Sulphuric, Per MIL-A-8625, Type II, Class 2	N	Y	336
B	Black Zinc Cobalt, Per ASTM B840-99, Grade 661, Type 0, Over Electroless Nickel	Y	Y	350
N	Electroless Nickel, per MIL-C-26074 Class 4, Grade (0.0010" Min)	Y	Y	96
P	Passivated (Stainless Steel) SAE-AMS-00-P-35 Type V)	Y	Y	1000
W	Cadmium Olive Drab Per QQ-P-416, Type II, Class 3, over Electroless Nickel. Per MIL-C-26074, Class 3/4, Grade B	Y	N	500
ZN	Zinc Nickel Black Passivate (5-12 Microns) Over Electroless Nickel (8-12 Microns), ASTM B 841 Class 1	Y	Y	500

Product Dimensions

Part No.:	Shell Size	H Max	DØ	K Max	ZØ Cable Max	BBØ Max	JJØ Max
IP-U*CA12#	10	1.491 (37.88)	0.74 (18.79)	0.375 (9.52)	0.375 (9.52)	0.493 (12.52)	0.588 (14.92)
IP-U*CA14#	12	1.527 (38.79)	0.865 (21.96)	0.375 (9.52)	0.531 (13.49)	0.665 (16.89)	0.783 (19.89)
IP-U*CA16#	14	1.693 (42.99)	0.990 (25.14)	0.375 (9.52)	0.641 (16.27)	0.807 (20.51)	0.926 (23.51)
IP-U*CA18#	16	1.842 (46.79)	1.146 (29.11)	0.375 (9.52)	0.687 (17.46)	0.821 (20.86)	0.939 (23.86)
IP-U*CH18#	18	1.654 (42.0)	1.271 (32.29)	0.375 (9.52)	0.750 (19.04)	0.891 (22.64)	1.010 (25.64)
IP-U*CH20#	20	1.693 (43.0)	1.428 (36.26)	0.375 (9.52)	0.813 (20.64)	0.954 (24.24)	1.072 (27.24)
IP-U*CH22#	22	1.811 (46.00)	1.552 (39.43)	0.375 (9.52)	0.937 (23.81)	1.095 (27.81)	1.213 (30.81)
IP-U*CH24#	24	1.811 (46.00)	1.552 (39.43)	0.375 (9.52)	1.00 (25.40)	1.157 (29.40)	1.276 (32.40)

Dimensions in Inches ± .008 (Millimetres in brackets)

Notes

- Additional plating and materials are available upon request.
- "P" Plating is only applicable when a stainless base material is selected.

Universal Backshell, Commercial Grade MIL-DTL D38999, Straight (Series 1)

Connector Series: MIL-DTL D38999 (Commercial Grade)
 Suitable With: D38999 Series 1
 Style: Banding Backshell, w/ O-ring
 Direction: Straight
 Part No.: IP-U*XXXX#

* Refers to Backshell Material
 # Refers to Plating Code
 XXXX Refers to Backshell Style & Connector Shell Size (See table below)

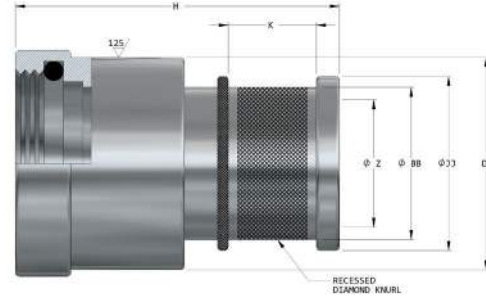

Material & Plating Information

IP-U*XXXX#

Material Code	Description	Material Code	Description
N	Aluminium	S4	Stainless Steel 304
S	Stainless Steel 303	S6	Stainless Steel 316

Plating Code	Description	Conductive	ROHS	Salt Spray
A	Black Anodize, Sulphuric, Per MIL-A-8625, Type II, Class 2	N	Y	336
G	Green Zinc Cobalt, Per ASTM B840-99, Grade 6, Over Electroless Nickel	Y	Y	350
N	Electroless Nickel, per MIL-C-26074 Class 4, Grade (0.0010" Min)	Y	Y	96
P	Passivated (Stainless Steel) SAE-AMS-00-P-35 Type V)	Y	Y	1000
W	Cadmium Olive Drab Per QQ-P-416, Type II, Class 3, over Electroless Nickel. Per MIL-C-26074, Class 3/4, Grade B	Y	N	500
ZN	Zinc Nickel Black Passivate (5-12 Microns) Over Electroless Nickel (8-12 Microns), ASTM B 841 Class 1	Y	Y	500

Product Dimensions

Part No.:	Shell Size	H Max	DØ	K Max	ZØ Cable Max	BBØ Max	JJØ Max
IP-U*CC8#	9	1.306 (33.2)	0.740 (18.8)	0.375 (9.52)	.312 (7.94)	0.391 (9.9)	0.486 (12.3)
IP-U*CC10#	11	1.382 (35.1)	0.74 (18.8)	0.375 (9.52)	.375 (9.52)	0.493 (12.5)	0.588 (14.9)
IP-U*CC12#	13	1.397 (35.5)	0.865 (21.97)	0.375 (9.52)	0.562 (14.29)	0.665 (16.9)	0.783 (19.9)
IP-U*CC14#	15	1.507 (38.3)	0.990 (25.1)	0.375 (9.52)	0.625 (15.87)	0.744 (18.9)	0.862 (21.9)
IP-U*CC16#	17	1.575 (40.0)	1.146 (29.1)	0.375 (9.52)	0.687 (17.46)	0.821 (20.86)	0.939 (23.86)
IP-U*CC18#	19	1.654 (42.0)	1.271 (32.29)	0.375 (9.52)	0.750 (19.04)	0.891 (22.64)	1.01 (25.64)
IP-U*CC20#	21	1.693 (43)	1.428 (36.26)	0.375 (9.52)	0.812 (20.64)	0.954 (24.24)	1.072 (27.24)
IP-U*CC22#	23	1.811 (46)	1.552 (39.43)	0.375 (9.52)	0.937 (23.81)	1.095 (27.81)	1.213 (30.81)
IP-U*CC24#	25	1.811 (46)	1.552 (39.43)	0.375 (9.52)	1.00 (25.40)	1.157 (29.40)	1.276 (32.40)

Dimensions in Inches ± .008 (Millimetres in brackets)

Notes

- Additional plating and materials are available upon request.
- "P" Plating is only applicable when a stainless base material is selected.

Universal Backshell, Commercial Grade MIL-DTL D38999, Straight (Series 2)

Connector Series: MIL-DTL D38999 (Commercial Grade)
 Suitable With: D38999 Series 2
 Style: Banding Backshell, w/ O-ring
 Direction: Straight
 Part No.: IP-U*XXXX#

* Refers to Backshell Material
 # Refers to Plating Code
 XXXX Refers to Backshell Style & Connector Shell Size (See table below)

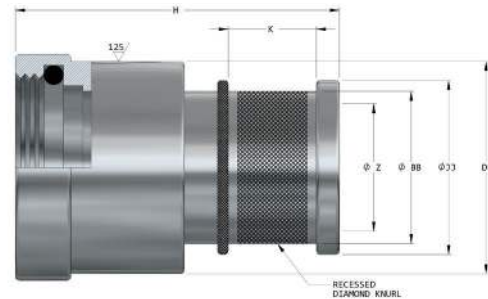

Material & Plating Information

IP-U*XXXX#

Material Code	Description	Material Code	Description
N	Aluminium	S4	Stainless Steel 304
S	Stainless Steel 303	S6	Stainless Steel 316

Plating Code	Description	Conductive	ROHS	Salt Spray
A	Black Anodize, Sulphuric, Per MIL-A-8625, Type II, Class 2	N	Y	336
G	Green Zinc Cobalt, Per ASTM B840-99, Grade 6, Over Electroless Nickel	Y	Y	350
N	Electroless Nickel, per MIL-C-26074 Class 4, Grade (0.0010" Min)	Y	Y	96
P	Passivated (Stainless Steel) SAE-AMS-00-P-35 Type V)	Y	Y	1000
TN	Teflon Nickel, Per ASTM-B841	Y	Y	500
W	Cadmium Olive Drab Per QQ-P-416, Type II, Class 3, over Electroless Nickel. Per MIL-C-26074, Class 3/4, Grade B	Y	N	500
ZN	Zinc Nickel Black Passivate (5-12 Microns) Over Electroless Nickel (8-12 Microns), ASTM B 841 Class 1	Y	Y	500

Product Dimensions

Part No.:	Shell Size	H Max	DØ	K Max	ZØ Cable Max	BBØ Max	JJØ Max
IP-U*CC8#	8	1.306 (33.2)	0.740 (18.8)	0.375 (9.52)	.312 (7.94)	0.391 (9.9)	0.486 (12.3)
IP-U*CC10#	10	1.382 (35.1)	0.74 (18.8)	0.375 (9.52)	.375 (9.52)	0.493 (12.5)	0.588 (14.9)
IP-U*CC12#	12	1.397 (35.5)	0.865 (21.97)	0.375 (9.52)	0.562 (14.29)	0.665 (16.9)	0.783 (19.9)
IP-U*CC14#	14	1.507 (38.3)	0.990 (25.1)	0.375 (9.52)	0.625 (15.87)	0.744 (18.9)	0.862 (21.9)
IP-U*CC16#	16	1.575 (40.0)	1.146 (29.1)	0.375 (9.52)	0.687 (17.46)	0.821 (20.86)	0.939 (23.86)
IP-U*CC18#	18	1.654 (42.0)	1.271 (32.29)	0.375 (9.52)	0.750 (19.04)	0.891 (22.64)	1.01 (25.64)
IP-U*CC20#	20	1.693 (43)	1.428 (36.26)	0.375 (9.52)	0.812 (20.64)	0.954 (24.24)	1.072 (27.24)
IP-U*CC22#	22	1.811 (46)	1.552 (39.43)	0.375 (9.52)	0.937 (23.81)	1.095 (27.81)	1.213 (30.81)
IP-U*CC24#	24	1.811 (46)	1.552 (39.43)	0.375 (9.52)	1.00 (25.40)	1.157 (29.40)	1.276 (32.40)

Dimensions in Inches ± .008 (Millimetres in brackets)

Notes

- Additional plating and materials are available upon request.
- "P" Plating is only applicable when a stainless base material is selected.

Universal Backshell, Commercial Grade MIL-DTL D38999, Straight (Series 3)

Connector Series: MIL-DTL D38999 (Commercial Grade)
 Suitable With: D38999 Series 3
 Style: Banding Backshell, w/ O-ring
 Direction: Straight
 Part No.: IP-U*XXXX#

* Refers to Backshell Material
 # Refers to Plating Code
 XXXX Refers to Backshell Style & Connector Shell Size (See table below)

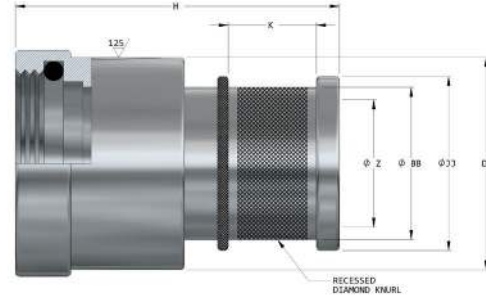

Material & Plating Information

IP-U*XXXX#

Material Code	Description	Material Code	Description
N	Aluminium	S4	Stainless Steel 304
S	Stainless Steel 303	S6	Stainless Steel 316

Plating Code	Description	Conductive	ROHS	Salt Spray
A	Black Anodize, Sulphuric, Per MIL-A-8625, Type II, Class 2	N	Y	336
G	Green Zinc Cobalt, Per ASTM B840-99, Grade 6, Over Electroless Nickel	Y	Y	350
N	Electroless Nickel, per MIL-C-26074 Class 4, Grade (0.0010" Min)	Y	Y	96
P	Passivated (Stainless Steel) SAE-AMS-00-P-35 Type V)	Y	Y	1000
TN	Teflon Nickel, Per ASTM-B841	Y	Y	500
W	Cadmium Olive Drab Per QQ-P-416, Type II, Class 3, over Electroless Nickel. Per MIL-C-26074, Class 3/4, Grade B	Y	N	500
ZN	Zinc Nickel Black Passivate (5-12 Microns) Over Electroless Nickel (8-12 Microns), ASTM B 841 Class 1	Y	Y	500

Product Dimensions

Part No.:	Shell Size	H Max	DØ	K Max	ZØ Cable Max	BBØ Max	JJØ Max
IP-U*CK9#	A/9	1.306 (33.18)	0.740 (18.8)	0.375 (9.52)	0.375 (9.52)	0.49 (12.52)	0.587 (14.92)
IP-U*CK11#	B/11	1.382 (35.10)	0.740 (18.8)	0.375 (9.52)	0.375 (9.52)	0.493 (12.52)	0.588 (14.92)
IP-U*CK13#	C/13	1.468 (37.29)	0.865 (21.96)	0.375 (9.52)	0.562 (14.29)	0.66 (16.89)	0.783 (19.89)
IP-U*CK15#	D/15	1.507 (38.28)	0.990 (25.14)	0.375 (9.52)	0.625 (15.88)	0.75 (18.92)	0.863 (21.92)
IP-U*CK17#	E/17	1.575 (40.0)	1.146 (29.11)	0.375 (9.52)	0.687 (17.46)	0.82 (20.86)	0.939 (23.86)
IP-U*CK19#	F/19	1.654 (42.01)	1.271 (32.29)	0.375 (9.52)	0.750 (19.04)	0.89 (22.64)	1.010 (25.64)
IP-U*CK21#	G/21	1.693 (43.0)	1.428 (36.26)	0.375 (9.52)	0.812 (20.64)	0.95 (24.24)	1.072 (27.24)
IP-U*CK23#	H/23	1.811 (46.0)	1.552 (39.43)	0.375 (9.52)	0.937 (23.81)	1.09 (27.81)	1.213 (30.81)
IP-U*CK25#	J/25	1.811 (46.0)	1.625 (41.28)	0.375 (9.52)	1.00 (25.41)	1.16 (29.41)	1.276 (32.41)

Dimensions in Inches ± .008 (Millimetres in brackets)

Notes

- Additional plating and materials are available upon request.
- "P" Plating is only applicable when a stainless base material is selected.

CG Adapter, Commercial Grade MIL-DTL 5015, Straight (AIT/AIB)

Connector Series: MIL-DTL 5015 (Commercial Grade)
 Suitable With: Amphenol AIT, AIB
 Style: Threaded Adapter, w/ O-ring
 Direction: Straight
 Part No.: IP-U*XXXX#-PGXX

* Refers to Backshell Material
 # Refers to Plating Code
 XXXX Refers to Backshell Style, PG Thread & Connector Shell Size (See table below)

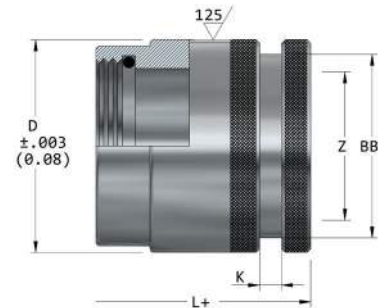

Material & Plating Information

IP-U*XXXX#-PGXX

Material Code	Description	Material Code	Description
N	Aluminium	S4	Stainless Steel 304
S	Stainless Steel 303	S6	Stainless Steel 316

Plating Code	Description	Conductive	ROHS	Salt Spray
A	Black Anodize, Sulphuric, Per MIL-A-8625, Type II, Class 2	N	Y	336
B	Black Zinc Cobalt, Per ASTM B840-99, Grade 661, Type 0, Over Electroless Nickel	Y	Y	350
G	Green Zinc Cobalt, Per ASTM B840-99, Grade 6, Over Electroless Nickel	Y	Y	350
N	Electroless Nickel, per MIL-C-26074 Class 4, Grade (0.0010" Min)	Y	Y	96
P	Passivated (Stainless Steel) SAE-AMS-00-P-35 Type V)	Y	Y	1000
W	Cadmium Olive Drab Per QQ-P-416, Type II, Class 3, over Electroless Nickel. Per MIL-C-26074, Class 3/4, Grade B	Y	N	500
ZG	Zinc Gray Nickel, Per ASTM-B84a	Y	Y	500
ZN	Zinc Nickel Black Passivate (5-12 Microns) Over Electroless Nickel (8-12 Microns), ASTM B 841 Class 1	Y	Y	500

Product Dimensions

Part No.:	Shell Size	L Max	DØ	K Max	ZØ Cable Max	BBØ Max
IP-U*AC8#-PG7	8S	See factory for information				
IP-U*AB10#-PG9	10SL	1.154 (29.30)	0.865 (21.97)	0.119 (3.0)	0.461 (11.70)	0.707 (17.97)
IP-U*AB12#-PG11	12/12S	1.24 (31.50)	0.99 (25.15)	0.119 (3.0)	0.461 (11.70)	0.833 (21.15)
IP-U*AB14#-PG13.5	14/14S	1.154 (29.30)	0.990 (25.14)	0.119 (3.0)	0.583 (14.80)	0.887 (22.54)
IP-U*AB16#-PG16	16/16S	1.386 (35.20)	1.146 (29.11)	0.119 (3.0)	0.701 (17.80)	0.989 (25.11)
IP-U*AB18#-PG16	18	1.386 (35.20)	1.271 (32.29)	0.119 (3.0)	0.823 (20.9)	1.114 (28.29)
IP-U*AB20#-PG21	20	1.496 (38)	1.428 (36.26)	0.119 (3.0)	0.982 (24.95)	1.27 (32.26)
IP-U*AB22#-PG21	22	1.496 (38)	1.428 (36.26)	0.119 (3.0)	1.059 (26.90)	1.27 (32.26)
IP-U*AB24#-PG21	24	1.496 (38.0)	1.552 (39.43)	0.119 (3.0)	1.185 (30.10)	1.395 (35.43)
IP-U*AB28#-PG29	28	1.535 (39.0)	1.82 (46.22)	0.119 (3.0)	1.339 (34.0)	1.662 (42.22)
IP-U*AB32#-PG29	32	1.673 (42.50)	2.055 (52.20)	0.119 (3.0)	1.626 (41.30)	1.898 (48.20)
IP-U*AB36#-PG36	36	1.673 (42.50)	2.291 (58.20)	0.119 (3.0)	1.882 (47.80)	2.134 (54.20)
IP-U*AB40#-PG36	40	1.988 (50.50)	2.520 (64.0)	0.119 (3.0)	2.126 (54.0)	2.362 (60.0)

Dimensions in Inches ± .008 (Millimetres in brackets)

Notes

- Alternative metric threads, additional plating and materials are available upon request.
- "P" Plating is only applicable when a stainless base material is selected.
- CG Adapter does not accommodate factory supplied wire sealing grommet or ferrule.

CG Adapter, Commercial Grade MIL-DTL 5015, Straight (CT/CB)

Connector Series: MIL-DTL 5015 (Commercial Grade)
 Suitable With: Cannon CT/CB
 Style: Threaded Adapter, w/ O-ring
 Direction: Straight
 Part No.: IP-U*XXXX#-PGXX

* Refers to Backshell Material
 # Refers to Plating Code
 XXXX Refers to Backshell Style, PG Thread & Connector Shell Size (See table below)

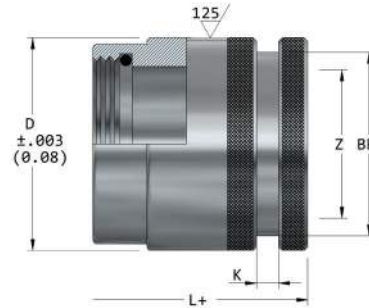

Material & Plating Information

IP-U*XXXX#-PGXX

Material Code	Description	Material Code	Description
N	Aluminium	S4	Stainless Steel 304
S	Stainless Steel 303	S6	Stainless Steel 316

Plating Code	Description	Conductive	ROHS	Salt Spray
A	Black Anodize, Sulphuric, Per MIL-A-8625, Type II, Class 2	N	Y	336
B	Black Zinc Cobalt, Per ASTM B840-99, Grade 661, Type 0, Over Electroless Nickel	Y	Y	350
G	Green Zinc Cobalt, Per ASTM B840-99, Grade 6, Over Electroless Nickel	Y	Y	350
N	Electroless Nickel, per MIL-C-26074 Class 4, Grade (0.0010" Min)	Y	Y	96
P	Passivated (Stainless Steel) SAE-AMS-00-P-35 Type V)	Y	Y	1000
W	Cadmium Olive Drab Per QQ-P-416, Type II, Class 3, over Electroless Nickel. Per MIL-C-26074, Class 3/4, Grade B	Y	N	500
ZN	Zinc Nickel Black Passivate (5-12 Microns) Over Electroless Nickel (8-12 Microns), ASTM B 841 Class 1	Y	Y	500

Product Dimensions

Part No.:	Shell Size	L Max	DØ	K Max	ZØ Cable Max	BBØ Max
IP-U*AC8#-PG7	8S	1.098 (27.90)	0.740 (18.80)	0.119 (3.0)	0.366 (9.3)	0.583 (14.8)
IP-U*AA10#-PG9	10SL	1.22 (31.00)	0.865 (21.97)	0.119 (3.0)	0.461 (11.7)	0.707 (17.97)
IP-U*AA12#-PG11	12/12S	1.240 (31.50)	0.990 (25.15)	0.119 (3.0)	0.512 (13.0)	0.833 (21.15)
IP-U*AA14#-PG13.5	14/14S	1.24 (31.5)	0.990 (25.14)	0.119 (3.0)	0.618 (15.70)	0.887 (22.54)
IP-U*AA16#-PG16	16/16S	1.358 (34.50)	1.146 (29.12)	0.119 (3.0)	0.740 (18.8)	0.989 (25.12)
IP-U*AA18#-PG16	18	1.555 (39.50)	1.146 (29.11)	0.119 (3.0)	0.870 (22.10)	0.989 (25.11)
IP-U*AA20#-PG21	20	1.575 (40.0)	1.428 (36.26)	0.119 (3.0)	1.00 (25.40)	1.270 (32.26)
IP-U*AA22#-PG21	22	1.606 (40.80)	1.428 (36.26)	0.119 (3.0)	1.126 (28.60)	1.270 (32.26)
IP-U*AA24#-PG21	24	1.606 (40.80)	1.552 (39.43)	0.119 (3.0)	1.094 (27.80)	1.395 (35.43)
IP-U*AA28#-PG29	28	1.646 (41.80)	1.772 (45.00)	0.119 (3.0)	1.469 (37.30)	1.614 (41.0)
IP-U*AA32#-PG29	32	1.665 (42.30)	2.043 (51.90)	0.119 (3.0)	1.535 (39.0)	1.886 (47.90)
IP-U*AA36#-PG36	36	1.673 (42.50)	2.291 (58.20)	0.119 (3.0)	1.756 (44.60)	2.134 (54.20)

Dimensions in Inches ± .008 (Millimetres in brackets)

Notes

- Alternative metric threads, additional plating and materials are available upon request.
- "P" Plating is only applicable when a stainless base material is selected.
- CG Adapter does not accommodate factory supplied wire sealing grommet or ferrule.

CG Adapter, Commercial Grade MIL-DTL 5015, Straight (MS345)

Connector Series: MIL-DTL 5015 (Commercial Grade)
 Suitable With: Crimp MS345 Rear Release
 Style: Threaded Adapter, w/ O-ring
 Direction: Straight
 Part No.: IP-U*XXXX#-PGXX

* Refers to Backshell Material
 # Refers to Plating Code
 XXXX Refers to Backshell Style, PG Thread & Connector Shell Size (See table below)

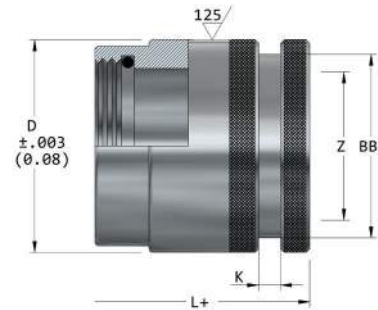

Material & Plating Information



Material Code	Description	Material Code	Description
N	Aluminium	S4	Stainless Steel 304
S	Stainless Steel 303	S6	Stainless Steel 316

Plating Code	Description	Conductive	ROHS	Salt Spray
A	Black Anodize, Sulphuric, Per MIL-A-8625, Type II, Class 2	N	Y	336
B	Black Zinc Cobalt, Per ASTM B840-99, Grade 661, Type 0, Over Electroless Nickel	Y	Y	350
G	Green Zinc Cobalt, Per ASTM B840-99, Grade 6, Over Electroless Nickel	Y	Y	350
N	Electroless Nickel, per MIL-C-26074 Class 4, Grade (0.0010" Min)	Y	Y	96
P	Passivated (Stainless Steel) SAE-AMS-00-P-35 Type V)	Y	Y	1000
W	Cadmium Olive Drab Per QQ-P-416, Type II, Class 3, over Electroless Nickel. Per MIL-C-26074, Class 3/4, Grade B	Y	N	500
ZG	Zinc Gray Nickel, Per ASTM-B841	Y	Y	500
ZN	Zinc Nickel Black Passivate (5-12 Microns) Over Electroless Nickel (8-12 Microns), ASTM B 841 Class 1	Y	Y	500

Product Dimensions

Part No.:	Shell Size	H Max	DØ	K Max	ZØ Cable Max	BBØ Max
IP-U*AA12#-PG11	10	1.24 (31.50)	0.99 (25.15)	0.119 (3.0)	0.512 (13)	0.833 (21.15)
IP-U*AA14#-PG13.5	12	1.24 (31.50)	0.99 (25.14)	0.119 (3.0)	0.618 (15.70)	0.887 (22.54)
IP-U*AA16#-PG16	14	1.24 (31.5)	0.990 (25.14)	0.119 (3.0)	0.618 (15.70)	0.887 (22.54)
IP-U*AA18#-PG16	16	1.358 (34.50)	1.146 (29.12)	0.119 (3.0)	0.740 (18.80)	0.989 (25.12)
IP-U*AC18#-PG16	18	1.256 (31.90)	1.271 (32.29)	0.119 (3.0)	0.963 (24.45)	1.14 (28.29)
IP-U*AC20#-PG21	20	1.319 (33.50)	1.428 (36.26)	0.119 (3.0)	1.083 (27.50)	1.27 (32.26)
IP-U*AC22#-PG21	22	1.488 (37.80)	1.552 (39.43)	0.119 (3.0)	1.193 (30.30)	1.395 (35.43)
IP-U*AC24#-PG21	24	1.52 (38.60)	1.552 (39.43)	0.119 (3.0)	1.317 (33.5)	1.395 (35.43)

Dimensions in Inches ± .008 (Millimetres in brackets)

Notes

- Alternative metric threads, additional plating and materials are available upon request.
- "P" Plating is only applicable when a stainless base material is selected.
- CG Adapter does not accommodate factory supplied wire sealing grommet or ferrule.

CG Adapter, Commercial Grade MIL-DTL 26482, Straight (Series 1)

Connector Series: MIL-DTL 26482 (Commercial Grade)
 Suitable With: 26482 Series 1, MS311#, MS312#,
 62GB, PT/PTSE, KPT/KPSE, Souriau 851.
 Style: Threaded Adapter, w/ O-ring
 Direction: Straight
 Part No.: IP-U*XXXX#-PGXX

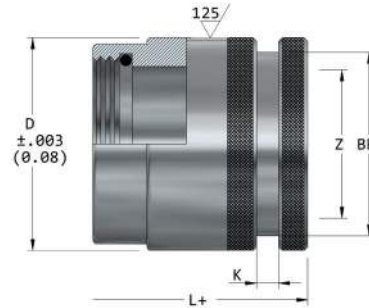

* Refers to Backshell Material
 # Refers to Plating Code
 XXXX Refers to Backshell Style, PG Thread & Connector Shell Size
 (See table below)

Material & Plating Information



Material Code	Description	Material Code	Description
N	Aluminium	S4	Stainless Steel 304
S	Stainless Steel 303	S6	Stainless Steel 316

Plating Code	Description	Conductive	ROHS	Salt Spray
A	Black Anodize, Sulphuric, Per MIL-A-8625, Type II, Class 2	N	Y	336
G	Green Zinc Cobalt, Per ASTM B840-99, Grade 6, Over Electroless Nickel	Y	Y	350
N	Electroless Nickel, per MIL-C-26074 Class 4, Grade (0.0010" Min)	Y	Y	96
P	Passivated (Stainless Steel) SAE-AMS-00-P-35 Type V)	Y	Y	1000
W	Cadmium Olive Drab Per QQ-P-416, Type II, Class 3, over Electroless Nickel. Per MIL-C-26074, Class 3/4, Grade B	Y	N	500
ZG	Zinc Gray Nickel, Per ASTM-B84a	Y	Y	500
ZN	Zinc Nickel Black Passivate (5-12 Microns) Over Electroless Nickel (8-12 Microns), ASTM B 841 Class 1	Y	Y	500

Product Dimensions

Part No.:	Shell Size	L Max	DØ	K Max	ZØ Cable Max	BBØ Max
IP-U*AC8#-PG7	8	1.098 (27.90)	0.740 (18.8)	0.119 (3.0)	0.366 (9.3)	0.583 (14.8)
IP-U*AC10#-PG9	10	1.098 (27.90)	0.865 (21.97)	0.119 (3.0)	0.488 (12.40)	0.707 (17.97)
IP-U*AC12#-PG11	12	1.118 (28.40)	0.990 (25.15)	0.119 (3.0)	0.61 (15.50)	0.833 (21.15)
IP-U*AC14#-PG13.5	14	1.138 (28.90)	0.990 (25.14)	0.119 (3.0)	0.724 (18.4)	0.887 (22.54)
IP-U*AC16#-PG16	16	1.138 (28.9)	1.146 (29.11)	0.119 (3.0)	0.835 (21.20)	0.989 (25.11)
IP-U*AC18#-PG16	18	1.256 (31.90)	1.271 (32.29)	0.119 (3.0)	0.963 (24.45)	1.114 (28.29)
IP-U*AC20#-PG21	20	1.319 (33.50)	1.428 (33.86)	0.119 (3.0)	1.083 (27.50)	1.27 (32.26)
IP-U*AC22#-PG21	22	1.488 (37.80)	1.552 (39.43)	0.119 (3.0)	1.193 (30.30)	1.395 (35.43)
IP-U*AC24#-PG21	24	1.52 (38.60)	1.552 (39.43)	0.119 (3.0)	1.317 (33.5)	1.395 (35.35)

Dimensions in Inches ± .008 (Millimetres in brackets)

Notes

- Alternative metric threads, additional plating and materials are available upon request.
- "P" Plating is only applicable when a stainless base material is selected.
- CG Adapter does not accommodate factory supplied wire sealing grommet or ferrule.

CG Adapter, Commercial Grade MIL-DTL 26482, Straight (Series 2)

Connector Series: MIL-DTL 26482 (Commercial Grade) Suitable
 With: 26482 Series 2
 Style: Threaded Adapter, w/ O-ring
 Direction: Straight
 Part No.: IP-U*XXXX#-PGXX

* Refers to Backshell Material
 # Refers to Plating Code
 XXXX Refers to Backshell Style, PG Thread & Connector Shell Size
 (See table below)

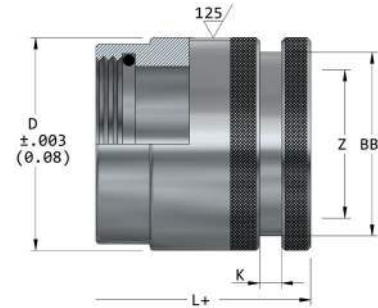

Material & Plating Information

IP-U*XXXX#-PGXX

Material Code	Description	Material Code	Description
N	Aluminium	S4	Stainless Steel 304
S	Stainless Steel 303	S6	Stainless Steel 316

Plating Code	Description	Conductive	ROHS	Salt Spray
A	Black Anodize, Sulphuric, Per MIL-A-8625, Type II, Class 2	N	Y	336
B	Black Zinc Cobalt, Per ASTM B840-99, Grade 661, Type 0, Over Electroless Nickel	Y	Y	350
N	Electroless Nickel, per MIL-C-26074 Class 4, Grade (0.0010" Min)	Y	Y	96
P	Passivated (Stainless Steel) SAE-AMS-00-P-35 Type V)	Y	Y	1000
W	Cadmium Olive Drab Per QQ-P-416, Type II, Class 3, over Electroless Nickel. Per MIL-C-26074, Class 3/4, Grade B	Y	N	500
ZN	Zinc Nickel Black Passivate (5-12 Microns) Over Electroless Nickel (8-12 Microns), ASTM B 841 Class 1	Y	Y	500

Product Dimensions

Part No.:	Shell Size	L Max	DØ	K Max	ZØ Cable Max	BBØ Max
IP-U*AA12#-PG11	10	1.24 (31.50)	0.99 (25.15)	0.119 (3.0)	0.512 (13)	0.833 (21.15)
IP-U*AA14#-PG13.5	12	1.24 (31.50)	0.99 (25.14)	0.119 (3.0)	0.618 (15.70)	0.887 (22.54)
IP-U*AA16#-PG16	14	1.24 (31.5)	0.990 (25.14)	0.119 (3.0)	0.618 (15.70)	0.887 (22.54)
IP-U*AA18#-PG16	16	1.358 (34.50)	1.146 (29.12)	0.119 (3.0)	0.740 (18.80)	0.989 (25.12)
IP-U*AC18#-PG16	18	1.256 (31.90)	1.271 (32.29)	0.119 (3.0)	0.963 (24.45)	1.14 (28.29)
IP-U*AC20#-PG21	20	1.319 (33.50)	1.428 (36.26)	0.119 (3.0)	1.083 (27.50)	1.27 (32.26)
IP-U*AC22#-PG21	22	1.488 (37.80)	1.552 (39.43)	0.119 (3.0)	1.193 (30.30)	1.395 (35.43)
IP-U*AC24#-PG21	24	1.52 (38.60)	1.552 (39.43)	0.119 (3.0)	1.317 (33.5)	1.395 (35.43)

Dimensions in Inches ± .008 (Millimetres in brackets)

Notes

- Alternative metric threads, additional plating and materials are available upon request.
- "P" Plating is only applicable when a stainless base material is selected.
- CG Adapter does not accommodate factory supplied wire sealing grommet or ferrule.

CG Adapter, Commercial Grade MIL-DTL D38999, Straight (Series 1)

Connector Series: MIL-DTL D38999 (Commercial Grade)
 Suitable With: D38999 Series 1
 Style: Threaded Adapter, w/ O-ring
 Direction: Straight
 Part No.: IP-U*XXXX#-PGXX

* Refers to Backshell Material
 # Refers to Plating Code
 XXXX Refers to Backshell Style, PG Thread & Connector Shell Size
 (See table below)

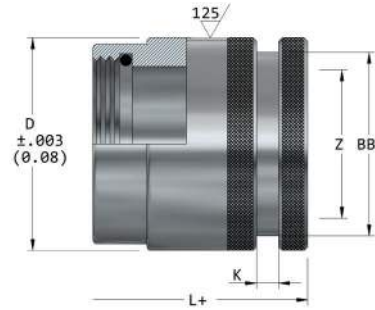

Material & Plating Information



Material Code	Description	Material Code	Description
N	Aluminium	S4	Stainless Steel 304
S	Stainless Steel 303	S6	Stainless Steel 316

Plating Code	Description	Conductive	ROHS	Salt Spray
A	Black Anodize, Sulphuric, Per MIL-A-8625, Type II, Class 2	N	Y	336
G	Green Zinc Cobalt, Per ASTM B840-99, Grade 6, Over Electroless Nickel	Y	Y	350
N	Electroless Nickel, per MIL-C-26074 Class 4, Grade (0.0010" Min)	Y	Y	96
P	Passivated (Stainless Steel) SAE-AMS-00-P-35 Type V)	Y	Y	1000
W	Cadmium Olive Drab Per QQ-P-416, Type II, Class 3, over Electroless Nickel. Per MIL-C-26074, Class 3/4, Grade B	Y	N	500
ZN	Zinc Nickel Black Passivate (5-12 Microns) Over Electroless Nickel (8-12 Microns), ASTM B 841 Class 1	Y	Y	500

Product Dimensions

Part No.:	Shell Size	L Max	DØ	K Max	ZØ Cable Max	BBØ Max
IP-U*AC8#-PG7	9	1.306 (33.2)	0.740 (18.8)	0.433 (11.0)	0.281 (7.1)	0.391 (9.9)
IP-U*AC10#-PG9	11	1.098 (27.90)	0.865 (21.97)	0.119 (3.0)	0.488 (12.40)	0.707 (17.97)
IP-U*AC12#-PG11	13	1.118 (28.40)	0.990 (25.15)	0.119 (3.0)	0.61 (15.50)	0.833 (21.15)
IP-U*AC14#-PG13.5	15	1.138 (28.90)	0.990 (25.14)	0.119 (3.0)	0.724 (18.4)	0.887 (22.54)
IP-U*AC16#-PG16	17	1.138 (28.9)	1.146 (29.11)	0.119 (3.0)	0.835 (21.20)	0.989 (25.11)
IP-U*AC18#-PG16	19	1.256 (31.90)	1.271 (32.29)	0.119 (3.0)	0.963 (24.45)	1.114 (28.29)
IP-U*AC20#-PG21	21	1.319 (33.50)	1.428 (33.86)	0.119 (3.0)	1.083 (27.50)	1.27 (32.26)
IP-U*AC22#-PG21	23	1.488 (37.80)	1.552 (39.43)	0.119 (3.0)	1.193 (30.30)	1.395 (35.43)
IP-U*AC24#-PG21	25	1.52 (38.60)	1.552 (39.43)	0.119 (3.0)	1.317 (33.5)	1.395 (35.35)

Dimensions in Inches ± .008 (Millimetres in brackets)

Notes

- Alternative metric threads, additional plating and materials are available upon request.
- "P" Plating is only applicable when a stainless base material is selected.
- CG Adapter does not accommodate factory supplied wire sealing grommet or ferrule.

CG Adapter, Commercial Grade MIL-DTL D38999, Straight (Series 2)

Connector Series: MIL-DTL D38999 (Commercial Grade)
 Suitable With: D38999 Series 2
 Style: Threaded Adapter, w/ O-ring
 Direction: Straight
 Part No.: IP-U*XXXX#-PGXX

* Refers to Backshell Material
 # Refers to Plating Code
 XXXX Refers to Backshell Style, PG Thread & Connector Shell Size
 (See table below)

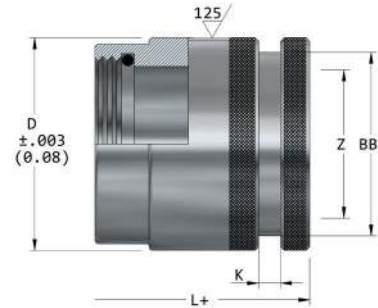

Material & Plating Information



Material Code	Description	Material Code	Description
N	Aluminium	S4	Stainless Steel 304
S	Stainless Steel 303	S6	Stainless Steel 316

Plating Code	Description	Conductive	ROHS	Salt Spray
A	Black Anodize, Sulphuric, Per MIL-A-8625, Type II, Class 2	N	Y	336
G	Green Zinc Cobalt, Per ASTM B840-99, Grade 6, Over Electroless Nickel	Y	Y	350
N	Electroless Nickel, per MIL-C-26074 Class 4, Grade (0.0010" Min)	Y	Y	96
P	Passivated (Stainless Steel) SAE-AMS-00-P-35 Type V	Y	Y	1000
TN	Teflon Nickel, Per ASTM-B841	Y	Y	500
W	Cadmium Olive Drab Per QQ-P-416, Type II, Class 3, over Electroless Nickel. Per MIL-C-26074, Class 3/4, Grade B	Y	N	500
ZN	Zinc Nickel Black Passivate (5-12 Microns) Over Electroless Nickel (8-12 Microns), ASTM B 841 Class 1	Y	Y	500

Product Dimensions

Part No.:	Shell Size	L Max	DØ	K Max	ZØ Cable Max	BBØ Max
IP-U*AC8#-PG7	8	1.306 (33.2)	0.740 (18.8)	0.433 (11.0)	0.281 (7.1)	0.391 (9.9)
IP-U*AC10#-PG9	10	1.098 (27.90)	0.865 (21.97)	0.119 (3.0)	0.488 (12.40)	0.707 (17.97)
IP-U*AC12#-PG11	12	1.118 (28.40)	0.990 (25.15)	0.119 (3.0)	0.61 (15.50)	0.833 (21.15)
IP-U*AC14#-PG13.5	14	1.138 (28.90)	0.990 (25.14)	0.119 (3.0)	0.724 (18.4)	0.887 (22.54)
IP-U*AC16#-PG16	16	1.138 (28.9)	1.146 (29.11)	0.119 (3.0)	0.835 (21.20)	0.989 (25.11)
IP-U*AC18#-PG16	18	1.256 (31.90)	1.271 (32.29)	0.119 (3.0)	0.963 (24.45)	1.114 (28.29)
IP-U*AC20#-PG21	20	1.319 (33.50)	1.428 (33.86)	0.119 (3.0)	1.083 (27.50)	1.27 (32.26)
IP-U*AC22#-PG21	22	1.488 (37.80)	1.552 (39.43)	0.119 (3.0)	1.193 (30.30)	1.395 (35.43)
IP-U*AC24#-PG21	24	1.52 (38.60)	1.552 (39.43)	0.119 (3.0)	1.317 (33.5)	1.395 (35.35)

Dimensions in Inches ± .008 (Millimetres in brackets)

Notes

- Alternative metric threads, additional plating and materials are available upon request.
- "P" Plating is only applicable when a stainless base material is selected.
- CG Adapter does not accommodate factory supplied wire sealing grommet or ferrule.

CG Adapter, Commercial Grade MIL-DTL D38999, Straight (Series 3)

Connector Series: MIL-DTL D38999 (Commercial Grade)
 Suitable With: D38999 Series 3
 Style: Threaded Adapter, w/ O-ring
 Direction: Straight
 Part No.: IP-U*XXXX#-PGXX

* Refers to Backshell Material
 # Refers to Plating Code
 XXXX Refers to Backshell Style, PG Thread & Connector Shell Size
 (See table below)

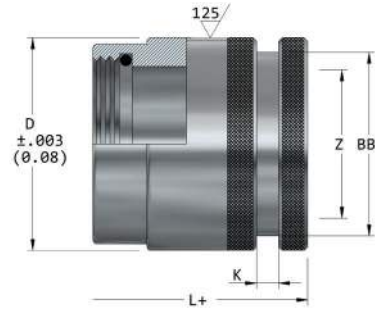

Material & Plating Information



Material Code	Description	Material Code	Description
N	Aluminium	S4	Stainless Steel 304
S	Stainless Steel 303	S6	Stainless Steel 316

Planning Code	Description	Conductive	ROHS	Salt Spray
A	Black Anodize, Sulphuric, Per MIL-A-8625, Type II, Class 2	N	Y	336
G	Green Zinc Cobalt, Per ASTM B840-99, Grade 6, Over Electroless Nickel	Y	Y	350
N	Electroless Nickel, per MIL-C-26074 Class 4, Grade (0.0010" Min)	Y	Y	96
P	Passivated (Stainless Steel) SAE-AMS-00-P-35 Type V)	Y	Y	1000
TN	Teflon Nickel, Per ASTM-B841	Y	Y	500
W	Cadmium Olive Drab Per QQ-P-416, Type II, Class 3, over Electroless Nickel. Per MIL-C-26074, Class 3/4, Grade B	Y	N	500
ZN	Zinc Nickel Black Passivate (5-12 Microns) Over Electroless Nickel (8-12 Microns), ASTM B 841 Class 1	Y	Y	500

Product Dimensions

Part No.:	Shell Size	L Max	DØ	K Max	ZØ Cable Max	BBØ Max
IP-U*AK9#-PG7	9	0.976 (24.80)	0.740 (18.8)	0.119 (3.0)	0.374 (9.50)	0.583 (14.80)
IP-U*AK11#-PG9	11	1.059 (26.90)	0.865 (21.97)	0.119 (3.0)	0.492 (12.50)	0.707 (17.97)
IP-U*AK13#-PG13.5	13	1.024 (26)	0.990 (25.14)	0.119 (3.0)	0.614 (15.60)	0.888 (22.54)
IP-U*AK15#-PG16	15	1.083 (27.50)	1.146 (29.11)	0.119 (3.0)	0.709 (18.0)	0.989 (25.11)
IP-U*AK17#-PG16	17	1.13 (28.70)	1.146 (29.11)	0.119 (3.0)	0.831 (21.10)	0.989 (25.11)
IP-U*AK19#-PG21	19	1.24 (31.50)	1.428 (36.26)	0.119 (3.0)	0.965 (24.50)	1.27 (32.26)
IP-U*AK21#-PG21	21	1.287 (32.70)	1.428 (36.26)	0.119 (3.0)	1.098 (27.90)	1.27 (32.26)
IP-U*AK23#-PG21	23	1.406 (35.70)	1.552 (39.43)	0.119 (3.0)	1.232 (31.30)	1.395 (35.43)
IP-U*AK25#-PG29	25	1.445 (36.70)	1.687 (42.85)	0.119 (3.0)	1.417 (36.00)	1.53 (38.85)

Dimensions in Inches ± .008 (Millimetres in brackets)

Notes

- Alternative metric threads, additional plating and materials are available upon request.
- "P" Plating is only applicable when a stainless base material is selected.
- CG Adapter does not accommodate factory supplied wire sealing grommet or ferrule.

Modification Codes

All of our Universal Backshell products also come with the ability to kit them with a spring band and electrical shielding tape. These options have been thoroughly tested for the last 25 years and brings a welcome reliable connection to interconnect design. Just add one of three modification codes to the end of your Universal Backshell part number!

IP-UNCK9W-W

Material Code	Description
-W	With shielding spring & shielding tape
-S	With shielding spring
-T	With shielding tape



IP-UNCK9W is used for example purposes only, modification codes can be added to all Universal Backshells.

Universal Backshell, Shielding Tape

Product Series: Universal Backshell

Suitable With: All

Style: Shielding Tape

Part No.: **PG93-03-003-1-SP25** (25 foot reel)



PEI-Genesis's Shielding Tape is the engineers choice for shielding cable splices, wire connectors or branch outs from EMI, RFI and EMF.

When installed with a 50% overlap, this product will accomplish a 98% shielding coverage, ensuring your wires and cables will not be compromised by damaging interferences.

Adhesion (24hr.)	55 oz/in. (to steel)	Particles	Silver Coated Nickel
Adhesive	Acrylic	Shelf Life	12 Months. Unbonded.
Electrical Resistance	< .049 ohms (1.0 sq-in)	Color	Translucent
Flammability	Fire Retardant	Solvent Resistance	Poor (soften & swell and is removable with chlorinated & aromatic solvents and Ketones).
Temperature Range	70°C Days/Weeks 121°C Minutes/Hours	Minimum Operating Temperature	-49 ° F (-45 ° C)
Electrical: AC Impedance	.044 ohms (500 Hz - 100 KHz)	Maximum Operating Temperature	302 ° F (150 ° C)
Release Liner	Polycoated Paper Liner	Shape of Installation	ALL
Electrical: Current Capacity	1 Amp/sq-in	Shielding	Shielding properties very good, call for details.
Closure	Conductive Adhesion		

Universal Backshell, Spring Band

Connector Series: Universal Backshell

Suitable With: All

Style: Spring Band

Direction: Straight

Part No.: BAND#

X Refers to Band size (See table below)



Please specify the correct band as per your Universal Backshell part number:

	BAND1	BAND2	BAND3	BAND4		BAND1	BAND2	BAND3	BAND4		BAND1	BAND2	BAND3	BAND4
IP-UNCA10	X				IP-UNCB22			X		IP-UNCH18			x	
IP-UNCA12	X				IP-UNCB24				X	IP-UNCH20			x	
IP-UNCA14		X			IP-UNCB28				X	IP-UNCH22				x
IP-UNCA16			X		IP-UNCB32				X	IP-UNCH24				x
IP-UNCA16S			X		IP-UNCB36				X	IP-UNCK11	X			
IP-UNCA18			X		IP-UNCB40				X	IP-UNCK13		X		
IP-UNCA20			X		IP-UNCB8	X				IP-UNCK15			X	
IP-UNCA22			X		IP-UNCC10	X				IP-UNCK17			X	
IP-UNCA24				X	IP-UNCC12		X			IP-UNCK19			X	
IP-UNCB10	X				IP-UNCC14			X		IP-UNCK21			X	
IP-UNCB12	X				IP-UNCC16			X		IP-UNCK23				X
IP-UNCB14		X			IP-UNCC18			X		IP-UNCK25				X
IP-UNCB16			X		IP-UNCC20			X		IP-UNCK9	X			
IP-UNCB16S			X		IP-UNCC22				X	IP-UNSA28				X
IP-UNCB18			X		IP-UNCC24				X	IP-UNSA32				X
IP-UNCB20			X		IP-UNCC8	X				IP-UNSA36				X

Please specify the correct band as per your Universal Backshell part number:

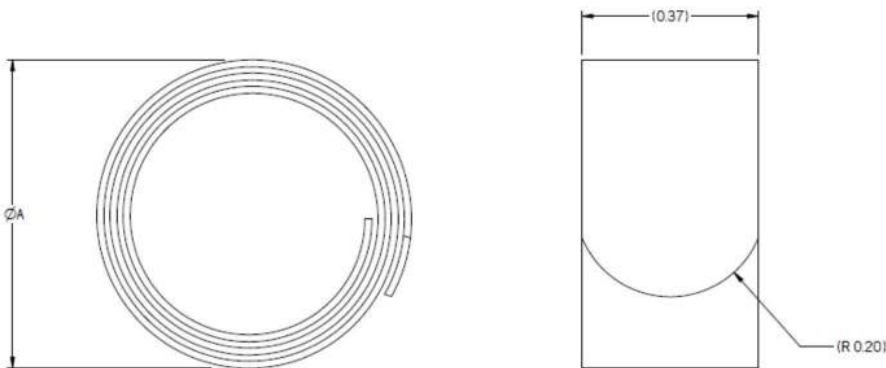

BAND #	Ø A (ref)	COILS (ref)
BAND 1	0.36 (9.14)	4.50
BAND 2	0.57 (14.47)	3.00
BAND 3	0.73 (18.54)	4.25
BAND 4	0.98 (24.89)	3.50

Notes

Band dimensions are in inches. (millimeters in brackets)



Corporate Headquarters, Philadelphia, PA



European Headquarters & Production Facility, Southampton, UK



Production Facility, Zhuhai, China



North American Production Facility, South Bend, IN



FilConn, Chandler, AZ



PEI-Genesis has sales offices throughout the Americas, Europe and Asia.
Visit www.peigenesis.com, call +1 800.675.1214 (North America), +44 (0) 23 8062 1260 (Europe),
+86 756 7683 088 (Asia), +1 631.475.5050 (Rest of World), or email: sales@peigenesis.com.

www.peigenesis.com | www.peigenesis.cn

SS_CSG_01
Rev.20201028

