

DO NOT SCALE FROM THIS PRINT

DESIGNED & DIMENSIONED IN INCHES[MILLIMETERS]

PRF18-J-C-EE-405-SD-X

- SERIES  
-18: 1.85MM
- GENDER  
-J: JACK
- TYPE  
-C: CABLE
- PLATING  
-EE: 50µ" EXTRA HEAVY GOLD CENTER CONTACT, 50µ" EXTRA HEAVY GOLD OUTER CONTACT
- PACKAGING  
-B: BULK (IN INCREMENTS OF 50) (BLANK): STANDARD PACKAGING
- TERMINATION  
-D: DIRECT SOLDER
- ORIENTATION  
-S: STRAIGHT
- CABLE TYPE  
-405: RG-405 SEMI RIGID

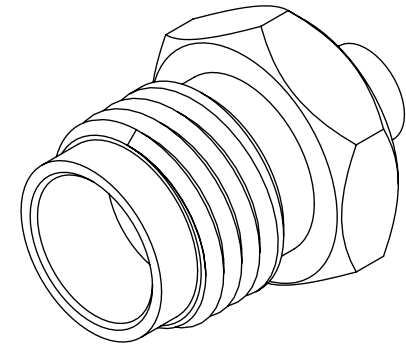
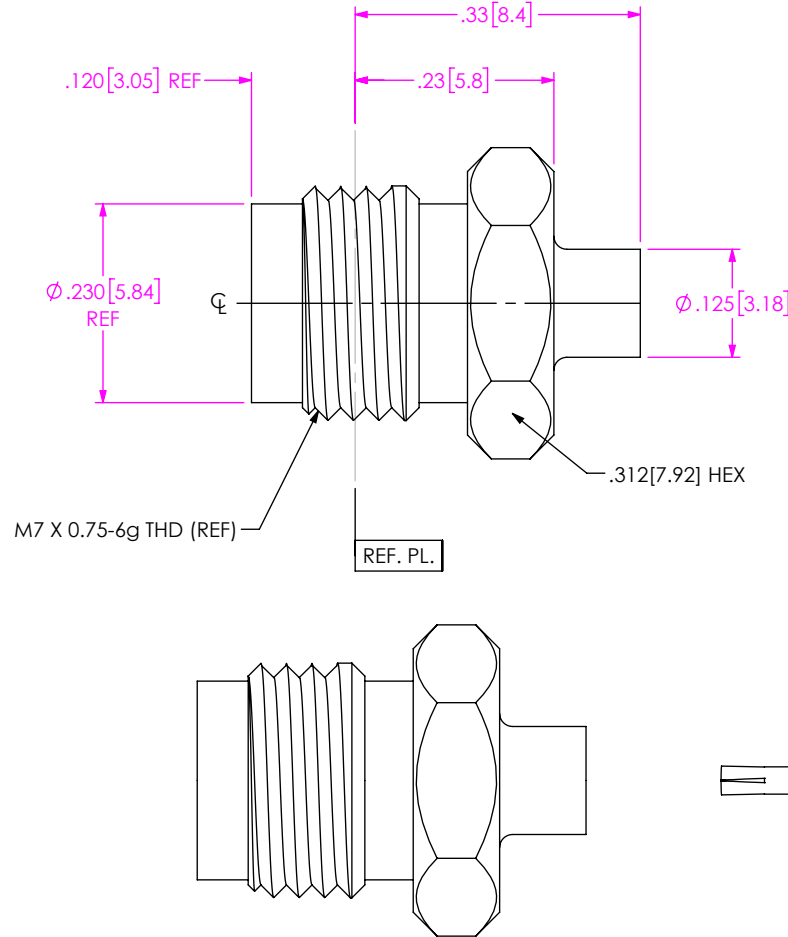

NOTES:

1. MATERIAL:  
BODY, CONTACT: BERYLLIUM COPPER
2. FINISH:  
BODY, CONTACT: 50µ" MIN. GOLD OVER 50µ" MIN. NICKEL PLATE
3. PERFORMANCE:  
IMPEDANCE: 50 Ω  
FREQUENCY: DC TO 65 GHz  
VSWR: 1.18:1 MAXIMUM  
INSERTION LOSS: 0.03 x √f(GHz)  
DWV: 900 Vrms
4. PCI P/N: 3231
5. BULK PACKAGING OPTION (-B) FOR ORDERS IN INCREMENTS OF 50 PCS.

EXPLODED VIEW  
NOT TO SCALE  
(FOR CLARITY ONLY)

F:\DWG\MISC\MKTG\PRF18-J-C-EE-405-SD-X-MKT.SLDDRW

UNLESS OTHERWISE SPECIFIED, DIMENSIONS ARE IN INCHES. TOLERANCES ARE: DECIMALS      ANGLES .XX: ±.02[0.5]      1° .XXX: ±.005[0.13] .XXXX: ±.0005[0.013]	* PROPRIETARY NOTE * THIS DOCUMENT CONTAINS CONFIDENTIAL AND PROPRIETARY INFORMATION AND ALL DESIGN, MANUFACTURING, REPRODUCTION, USE, PATENT RIGHTS AND SALES RIGHTS ARE EXPRESSLY RESERVED BY SAMTEC, INC. THIS DOCUMENT SHALL NOT BE DISCLOSED, IN WHOLE OR PART, TO ANY UNAUTHORIZED PERSON OR ENTITY NOR REPRODUCED, TRANSFERRED OR INCORPORATED IN ANY OTHER PROJECT IN ANY MANNER WITHOUT THE EXPRESS WRITTEN CONSENT OF SAMTEC, INC.	 520 PARK EAST BLVD, NEW ALBANY, IN 47150 PHONE: 812-944-6733      FAX: 812-948-5047 e-Mail info@SAMTEC.com      code 55322	
		MATERIAL: DO NOT SCALE DRAWING      SHEET SCALE: 4.5:1	DESCRIPTION: 1.85MM JACK FOR RG-405 CABLE
		DWG. NO. PRF18-J-C-EE-405-SD-X	BY: CANDY W 04/29/2019      SHEET 1 OF 2

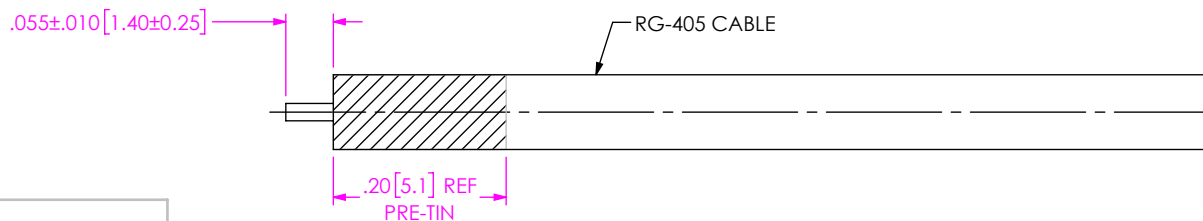

- 1A. TRIM CABLE JACKET & DIELECTRIC TO EXPOSE CENTER CONDUCTOR AS SHOWN (DO NOT NICK CENTER CONDUCTOR).
- 1B. PRE-TIN CABLE JACKET TO THE APPROXIMATE LENGTH SHOWN.

IN-PROCESS VIEW 1

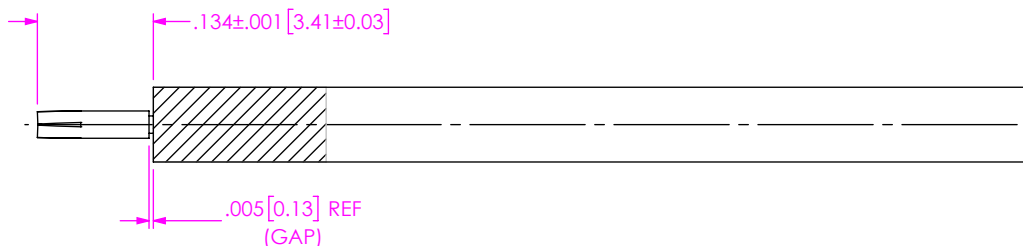

- 2. PRE-TIN CABLE CENTER CONDUCTOR AND SOLDER ON CONTACT TO DIMENSION SHOWN.

IN-PROCESS VIEW 2

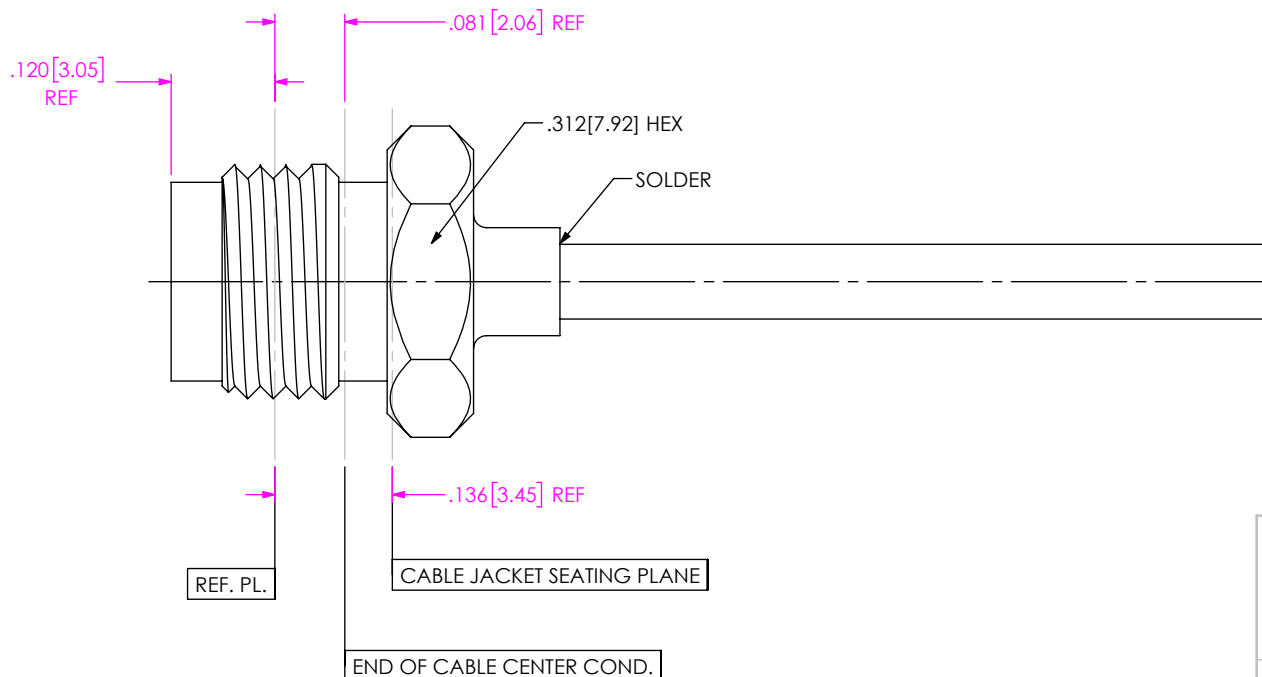

DISTANCE FROM END OF CABLE CENTER COND. TO REF. PL. IS .081 (REF.)

- 3A. INSERT CABLE/CONTACT SUB-ASSEMBLY INTO CONNECTOR UNTIL SEATED AND SOLDER WHERE INDICATED.
- 3B. GAGE INTERFACE USING APPROPRIATE GAGE (CONTACT RANGE .000/.003 SUB-FLUSH).

IN-PROCESS VIEW 3

**PROPRIETARY NOTE**  
 THIS DOCUMENT CONTAINS CONFIDENTIAL AND PROPRIETARY INFORMATION AND ALL DESIGN, MANUFACTURING, REPRODUCTION, USE, PATENT RIGHTS AND SALES RIGHTS ARE EXPRESSLY RESERVED BY SAMTEC, INC. THIS DOCUMENT SHALL NOT BE DISCLOSED, IN WHOLE OR PART, TO ANY UNAUTHORIZED PERSON OR ENTITY NOR REPRODUCED, TRANSFERRED OR INCORPORATED IN ANY OTHER PROJECT IN ANY MANNER WITHOUT THE EXPRESS WRITTEN CONSENT OF SAMTEC, INC.

**samtec**  
 520 PARK EAST BLVD, NEW ALBANY, IN 47150  
 PHONE: 812-944-6733 FAX: 812-948-5047  
 e-Mail: info@SAMTEC.com code 55322

DO NOT SCALE DRAWING  
 SHEET SCALE: 4.5:1

DESCRIPTION: 1.85MM JACK FOR RG-405 CABLE  
 DWG. NO. PRF18-J-C-EE-405-SD-X  
 BY: CANDY W 04/29/2019 SHEET 2 OF 2