

LOC		DIST		REVISIONS			
P	LTR	DESCRIPTION	DATE	DMN	APVD		
A3		REVISED PER ECO-11-004835	11MAR11	RK	HMR		

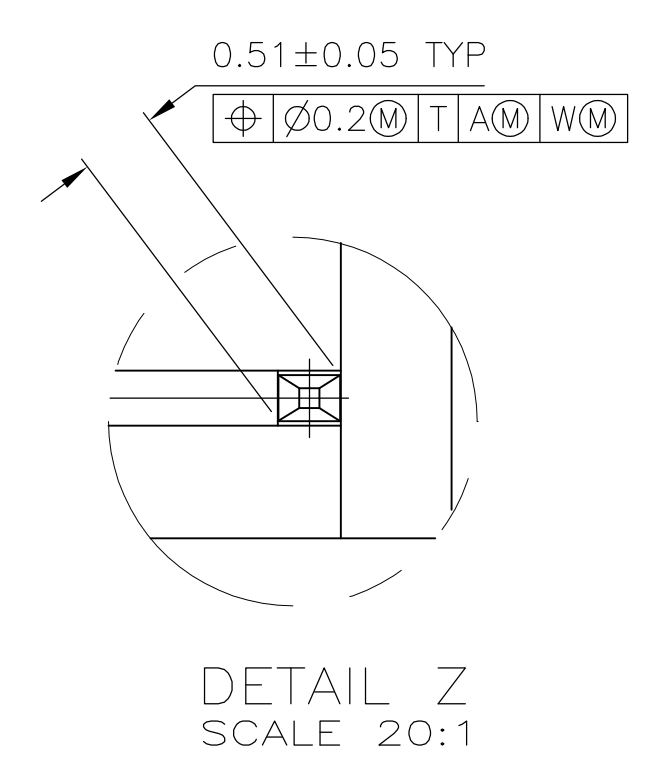
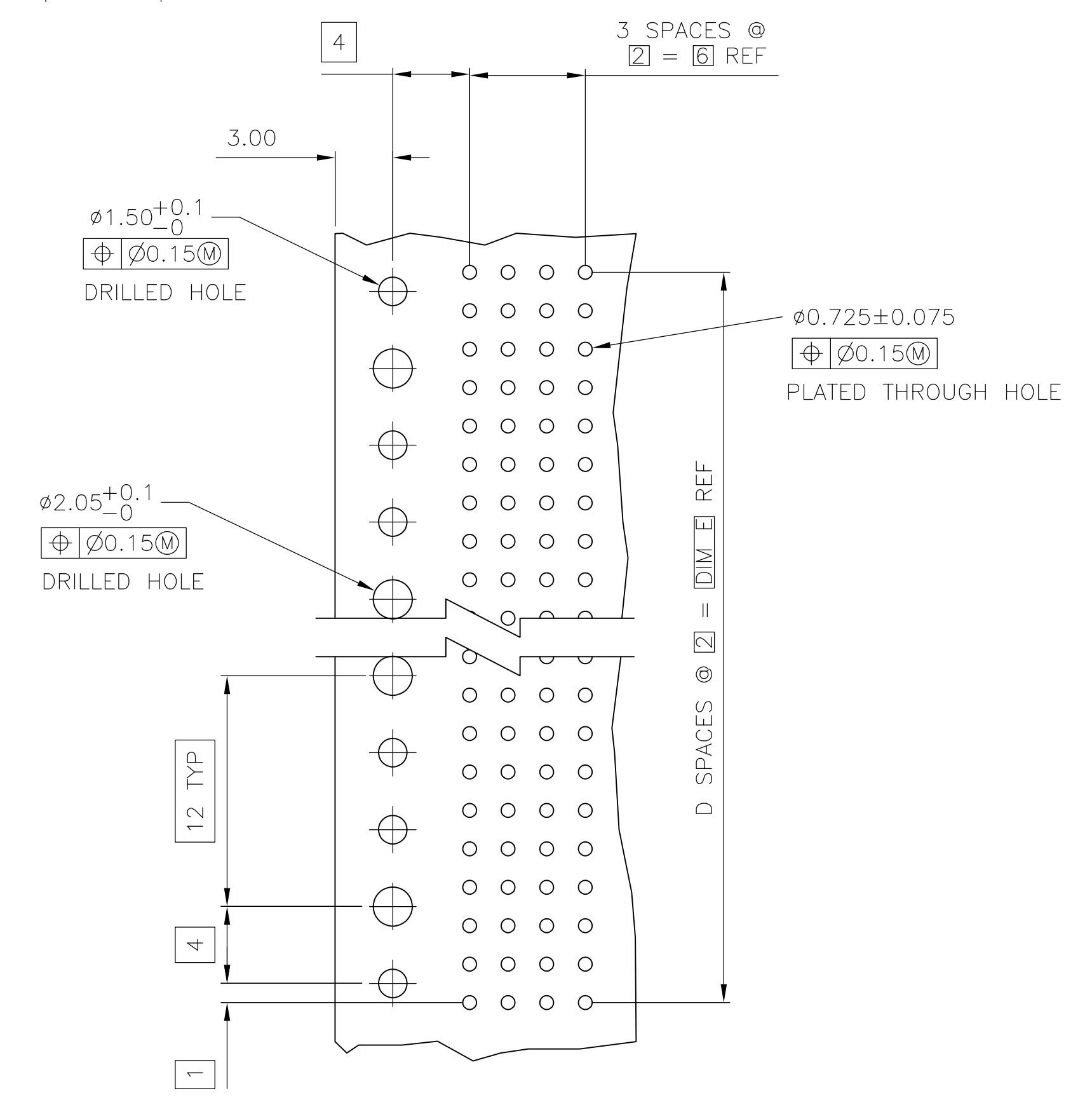
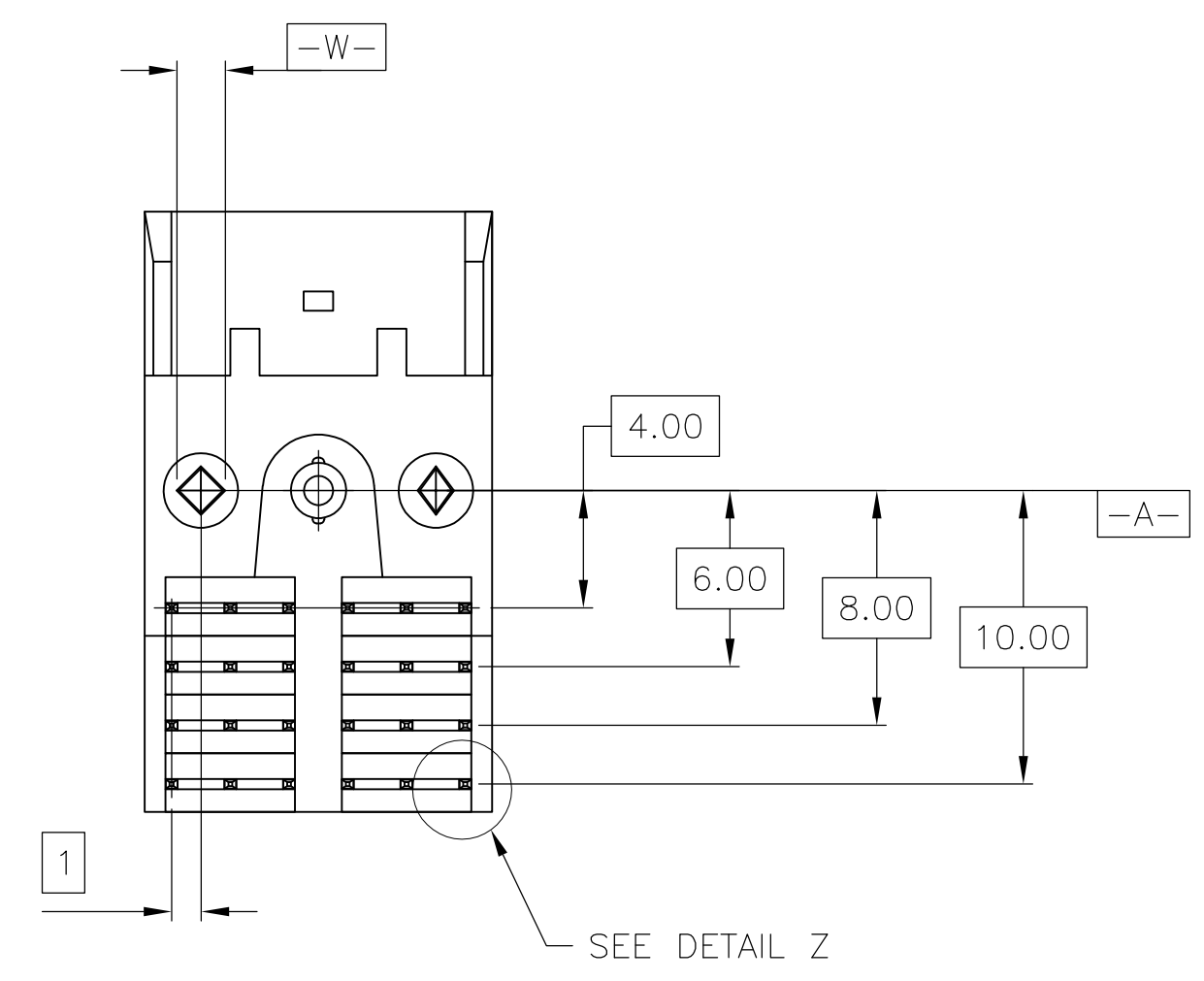
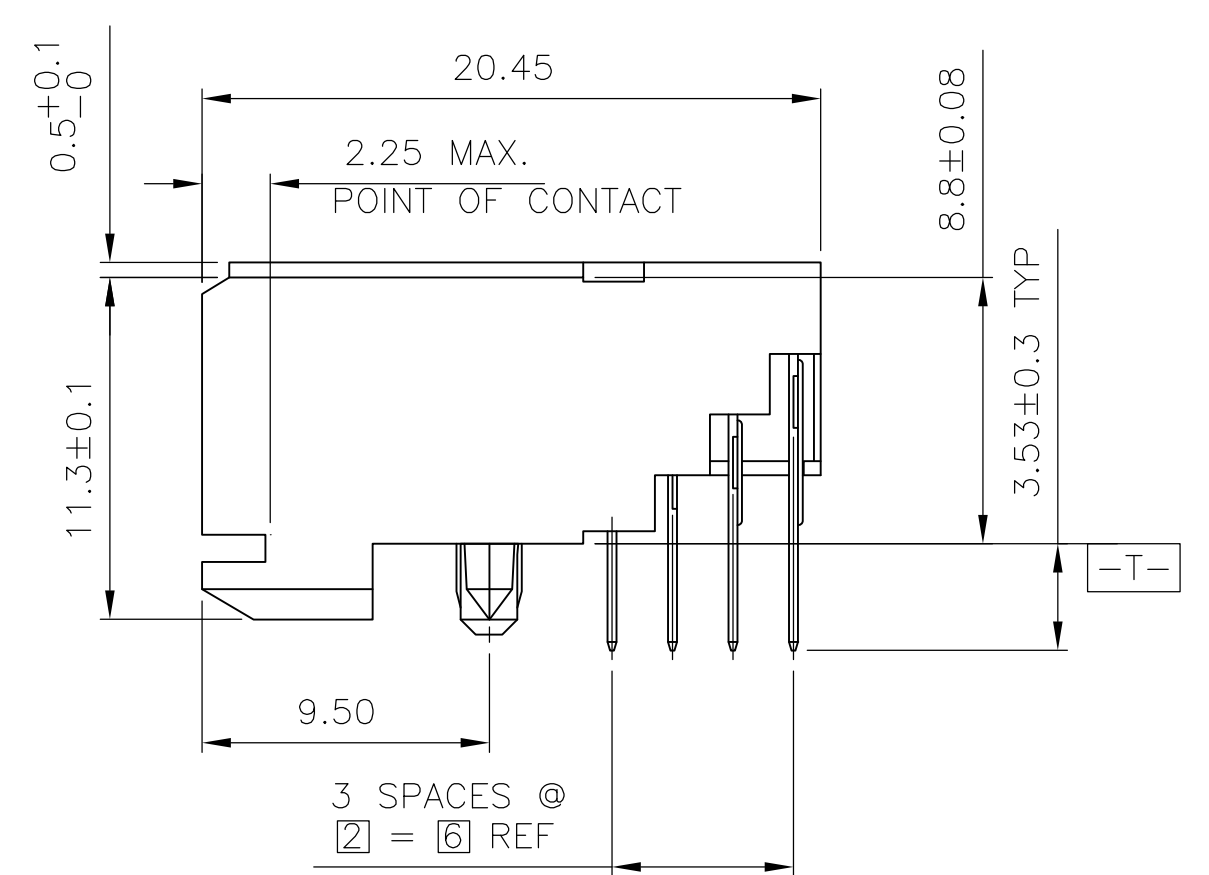
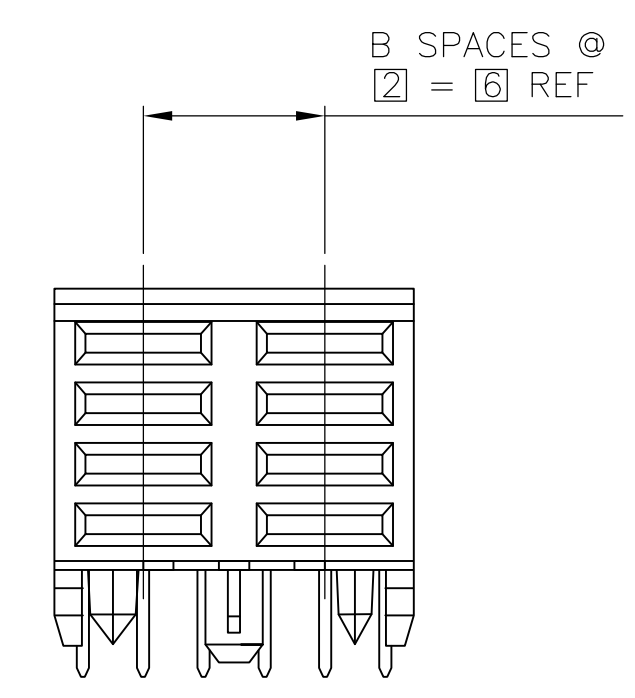
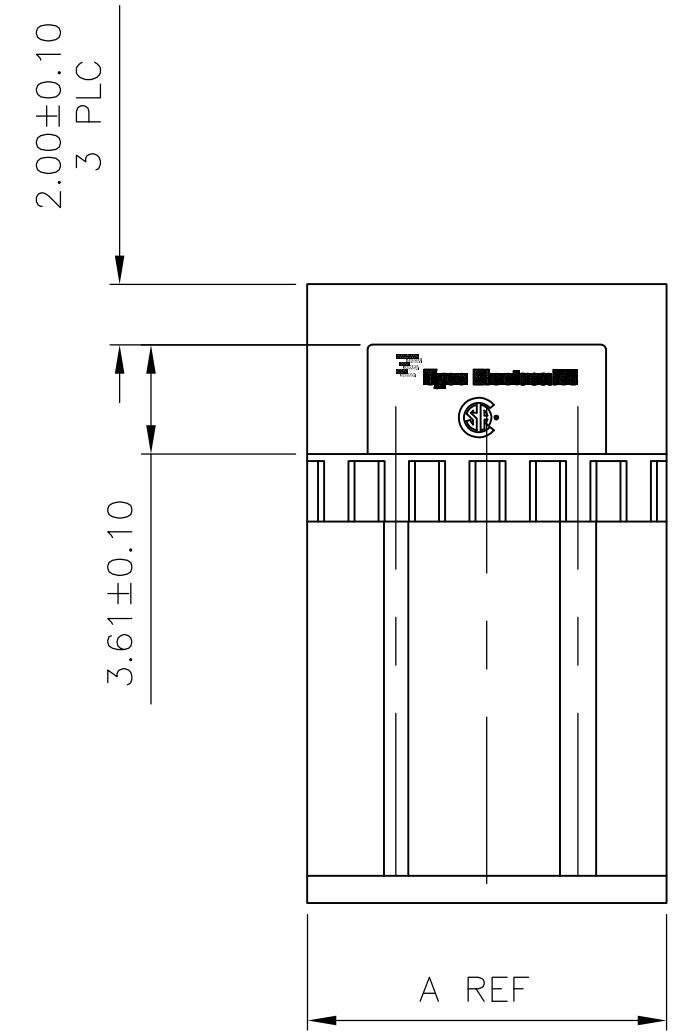

- 1 HOUSING MATERIAL: LIQUID CRYSTAL POLYMER.
- 2 CONTACT MATERIAL: PHOSPHOR-BRONZE.
- 3 CONTACT FINISH:(D)  
 UNDERPLATE (ENTIRE CONTACT):  
 0.00127 MIN NICKEL PER SAE-AMS-QQ-N-290  
 ON MATING SURFACES:  
 FLASH GOLD PER ASTM B 488, OVER  
 0.00076 MIN PALLADIUM-NICKEL OVER UNDERPLATE, OR  
 0.00076 MIN GOLD PER ASTM B 488 OVER UNDERPLATE.  
 ON LEADS:  
 0.00381 MIN MATTE TIN PER ASTM B 545 OVER UNDERPLATE.  
 LUBRICATION (MIN MATING SURFACES):  
 SURFACE CONDITIONER AFTER PLATING.

RECOMMENDED CIRCUIT PATTERN  
 PER IPC-D300 TYPE II, CLASS C  
 (COMPONENT SIDE)

10	5	6	1	11.88	3	8	5536613-1
E	D	C	B	A	FINISH	NO OF POSN	PART NUMBER
THIS DRAWING IS A CONTROLLED DOCUMENT.				DIN D.R.BENDER 09/17/92		STE TE Connectivity	
DIMENSIONS: mm				CHK S.HEADER 01/25/93		NAME	
TOLERANCES UNLESS OTHERWISE SPECIFIED:				APVD		PRODUCT SPEC	
0 PLC ± -				-		Z-PACK 2mm FB, POWER MODULE, RCPT. ASSY.	
1 PLC ± -				-		4 ROW, 3.53 mm LEAD LENGTH	
2 PLC ± 0.13				-		APPLICATION SPEC	
3 PLC ± -				-		SIZE	
4 PLC ± -				-		CAGE CODE	
ANGLES ± -				-		DRAWING NO	
MATERIAL				FINISH		WEIGHT	
1				2		A1 00779 5536613	
CUSTOMER DRAWING				SCALE 4:1		SHEET 1 OF 1 REV A3	