

CATALOG NUMBER	MATERIAL NUMBER	CABLE RANGE	LENGTH "M"	N.P.T. FITTING SIZE	FORM SIZE	LENGTH "A" REF.	LENGTH "B" REF.	UL LISTED	CSA APPROVED
5523NM	1300990071	.187-.250 / 4.75-6.35	4.00±0.50 / 101.6±12.7	1/2	2	0.563 / 14.30	1.250 / 31.75	YES	YES
5525NM	1300990075	.250-.312 / 6.35-7.92	4.00±0.50 / 101.6±12.7						
5527NM	1300990079	.312-.375 / 7.92-9.53	4.00±0.50 / 101.6±12.7						
5529NM	1300990083	.375-.437 / 9.53-11.10	5.50±0.50 / 139.7±12.7						
5531NM	1300990087	.437-.500 / 11.10-12.70	5.50±0.50 / 139.7±12.7						
5621NM	1300990156	.187-.250 / 4.75-6.35	4.50±0.50 / 114.3±12.7	3/4	3	0.549 / 13.94	1.401 / 35.59	YES	YES
5623NM	1300990160	.250-.375 / 6.35-9.53	4.00±0.50 / 101.6±12.7						
5625NM	1300990163	.375-.437 / 9.53-11.10	5.50±0.50 / 139.7±12.7						
5537NM	1300990095	.437-.562 / 11.10-14.27	5.75±0.50 / 146.1±12.7						
5539NM	1300990099	.500-.625 / 12.70-15.88	6.50±0.50 / 165.1±12.7						
5541NM	1300990103	.562-.687 / 14.27-17.45	6.50±0.50 / 165.1±12.7	1	4	0.813 / 20.65	1.812 / 46.02	YES	YES
5543NM	1300990107	.625-.750 / 15.88-19.05	8.50±1.00 / 215.9±25.4						
5547NM	1300990112	.437-.562 / 11.10-14.27	5.75±0.50 / 146.1±12.7						
5549NM	1300990115	.500-.625 / 12.70-15.88	6.50±0.50 / 165.1±12.7						
5551NM	-----	.562-.687 / 14.27-17.45	8.50±1.00 / 215.9±25.4						
5553NM	1300990122	.625-.750 / 15.88-19.05	8.50±1.00 / 215.9±25.4	1	4	0.813 / 20.65	1.812 / 46.02	YES	YES
5555NM	1300990126	.687-.812 / 17.45-20.62	8.50±1.00 / 215.9±25.4						
5557NM	1300990130	.750-.875 / 19.05-22.23	8.50±1.00 / 215.9±25.4						
5559NM	1300990133	.812-.937 / 20.62-23.80	8.50±1.00 / 215.9±25.4						
5561NM	1300990137	.875-1.000 / 22.23-25.40	8.50±1.00 / 215.9±25.4						

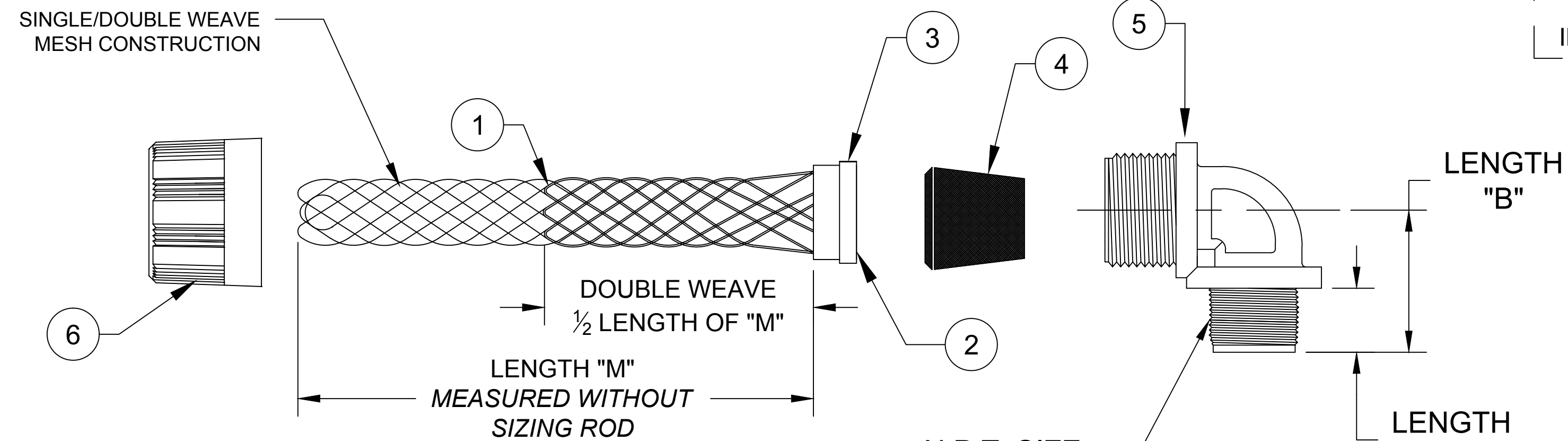
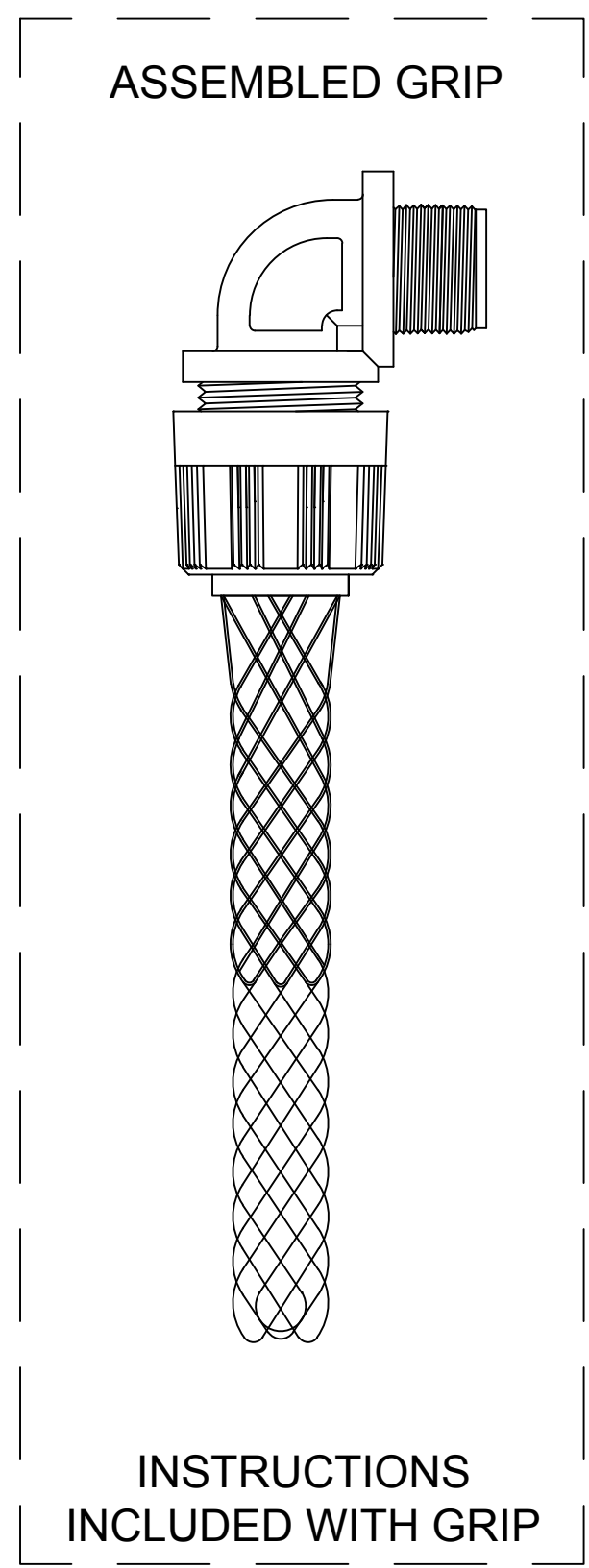

ITEM	DESCRIPTION	MATERIAL
1	WIRE MESH	POLYESTER (BLACK)
2	INNER RING	POLYETHYLENE TEREPHTHALATE (GRAY)
3	OUTER RING	POLYETHYLENE TEREPHTHALATE (GRAY)
4	GROMMET	NITRILE PVC
5	THREADED BODY	NYLON (GRAY)
6	COMPRESSION NUT	NYLON (GRAY)

RELEASE SALES DWG EC NO.: IFCG2014-2088 DRWN: HRUIZ01 2014/10/01 CHKD: HKNEELAN 2014/10/01 APPR: JFMURPHY 2014/11/18	QUALITY SYMBOL	GENERAL TOLERANCES (UNLESS SPECIFIED)	DIMENSION STYLE INCH/MM	SCALE NTS	DESIGN UNITS INCH	THIRD ANGLE PROJECTION
	▽=0	4 PLACES ±---	mm INCH	DRWN BY HRUIZ01	DATE 2014/10/01	STRAIN RELIEF MAX-LOC METALLIC RIGHT ANGLE MALE
	∇=0	3 PLACES ±---		CHECKED BY HKNEELAN	DATE 2014/10/01	
			2 PLACES ±.13 ±.010		APPROVED BY JFMURPHY	DATE 2014/11/18
		1 PLACE ±.25 ±.020		MATERIAL NO. SEE TABLE		DOCUMENT NO. SD-130099-006
				DRAFT WHERE APPLICABLE MUST REMAIN WITHIN DIMENSIONS		SHEET NO. 1 OF 1
				THIS DRAWING CONTAINS INFORMATION THAT IS PROPRIETARY TO MOLEX INCORPORATED AND SHOULD NOT BE USED WITHOUT WRITTEN PERMISSION		