

THIS DRAWING IS UNPUBLISHED. RELEASED FOR PUBLICATION
 © COPYRIGHT - By - ALL RIGHTS RESERVED.

REVISIONS					
P	LTR	DESCRIPTION	DATE	DWN	APVD
	L2	REVISED PER ECR-18-005284	18APR2018	RS	LB

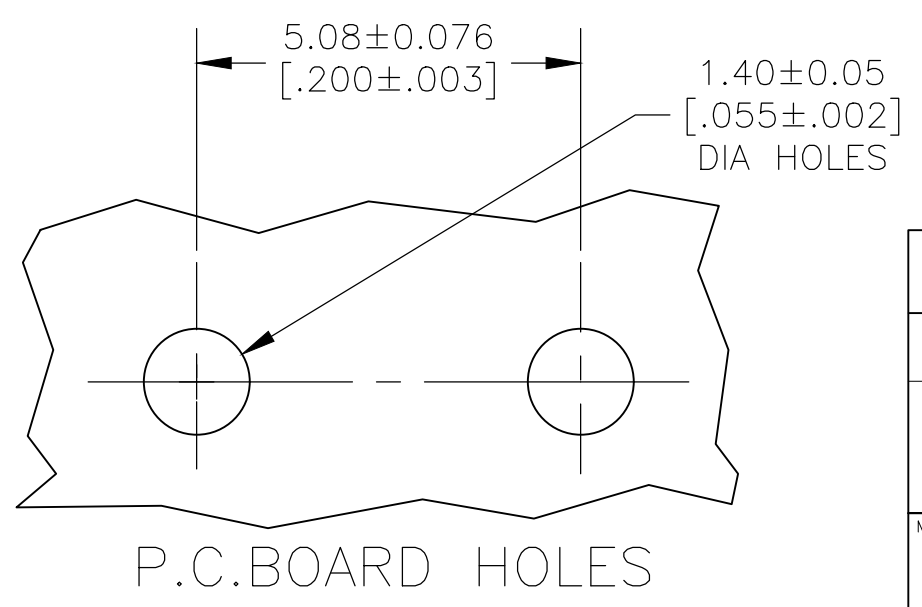
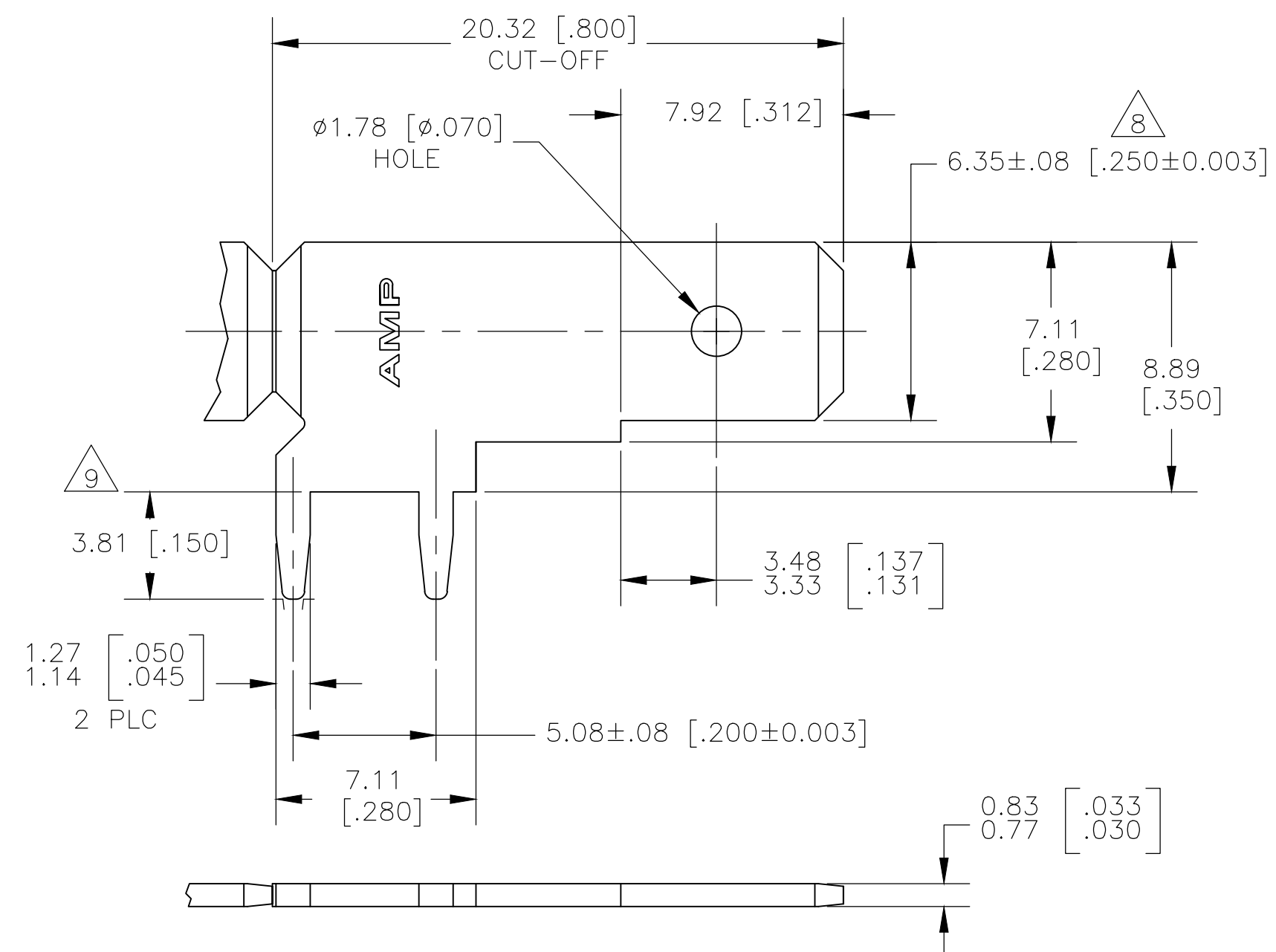

- 1 CONTINUOUS STRIP ON REELS.
- 2 0.00381 [.000150] MIN TIN OVER 0.00127 [.000050] MIN NICKEL.
- 3 REVERSE REELING OF 63951-1
- 4 0.00305 [.000120] MIN SILVER OVER 0.00127 [.000050] MIN NICKEL
- 5 REELED WITH INTERLEAVING PAPER
- 6 PRELIMINARY - NOT FOR PRODUCTION
- 7 0.00127 [.000050] MIN NICKEL ALL OVER FOR 63951-5 ONLY
- 8 0.00076 [.000030] MIN SELECTIVE GOLD, BOTH SIDES, 63951-5 ONLY.
- 9 0.002032 [.000080] MIN SELECTIVE LEAD FREE TIN, BOTH SIDES, 63951-5 ONLY.
- 10 REVERSE REELED WITH TAB OFF FIRST AND PCB POSTS FACING AWAY.
- 11 REELED WITH NO SPLICE

11	2	1-63951-1			
5	10	2	6	63951-9	
10	2	63951-8			
	7	8	9	6	63951-5
5	2	63951-4			
11	4	63951-3			
3	2	6	63951-2		
	2	63951-1			
FINISH				PART NO.	

THIS DRAWING IS A CONTROLLED DOCUMENT.		DWN	JR RUTH	11DEC00	STE TE Connectivity		
DIMENSIONS: INCHES		CHK	MS FEHER	11DEC00			
TOLERANCES UNLESS OTHERWISE SPECIFIED:		APVD	G PORTA	11DEC00	NAME		
0 PLC	± -	PRODUCT SPEC		TAB, FASTON, 6.35 [.250] SERIES			
1 PLC	± -	APPLICATION SPEC		SIZE			
2 PLC	± 0.25 [.010]	114-2115		CAGE CODE		DRAWING NO	
3 PLC	± -	WEIGHT		A3		00779	
4 PLC	± -	CUSTOMER DRAWING		C=		63951	
ANGLES	± -	SCALE		SHEET		REV	
FINISH	SEE TABLE	5:1		1 OF 1		L2	