

MAXIM

Fixed Output 10W CMOS Step-Up Switching Regulators

MAX641/642/643

General Description

The MAX641/MAX642/MAX643 step-up switching regulators are designed for minimum component DC-DC converter circuits in the 5mW to 10W range.

Low-power applications require only an output filter capacitor and a small, low-cost inductor. An additional MOSFET or bipolar transistor is needed for high-power applications. Low battery detection circuitry is included on chip.

The MAX641/642/643 are preset for +5V, +12V, and +15V outputs, respectively. However, the regulators can be set to other levels by adding 2 resistors. Maxim manufactures a broad line of step-up, step-down, and inverting DC-DC converters with features such as logic-level shutdown, adjustable oscillator frequency, and external MOSFET drive. See Table 3 for a summary of other DC-DC converter products.

Applications

- Simple, High-Efficiency DC-DC Converters
- Uninterruptible Board-Level Power Supplies
- Power Conditioning for Battery Systems
- Portable Instruments and Communications

Pin Configuration

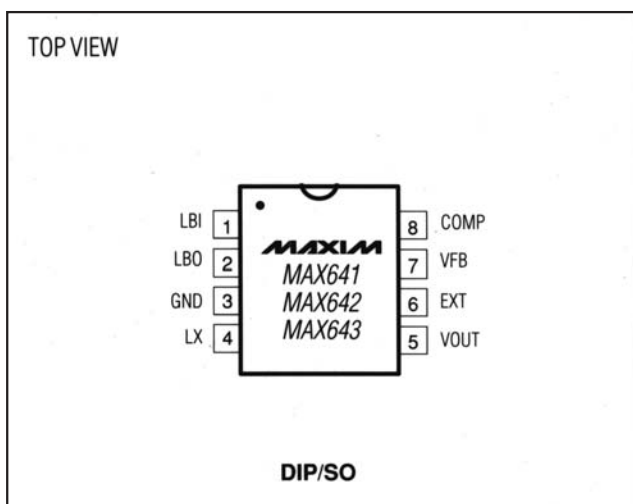

Features

- ◆ Fixed +5V, +12V, +15V Output Voltages
- ◆ Adjustable Output with 2 Resistors
- ◆ On-Chip Driver for High-Power External MOSFET
- ◆ 135 μ A Typ Operating Current
- ◆ 80% Typ Efficiency
- ◆ 8-Pin Narrow DIP and Narrow SO Packages

Ordering Information

PART*	TEMP. RANGE	PIN-PACKAGE
MAX641XCPA	0°C to +70°C	8 Plastic DIP
MAX641XCSA	0°C to +70°C	8 Narrow SO
MAX641XC/D	0°C to +70°C	Dice
MAX641XEPA	-40°C to +85°C	8 Plastic DIP
MAX641XESA	-40°C to +85°C	8 Narrow SO
MAX641XEJA	-40°C to +85°C	8 CERDIP
MAX641XMJA	-55°C to +125°C	8 CERDIP
MAX642XCPA	0° to +70°C	8 Plastic DIP
MAX642XCSA	0° to +70°C	8 Narrow SO
MAX642XC/D	0° to +70°C	Dice
MAX642XEPA	-40°C to +85°C	8 Plastic DIP
MAX642XESA	-40°C to +85°C	8 Narrow SO
MAX642XEJA	-40°C to +85°C	8 CERDIP
MAX642XMJA	-55°C to +125°C	8 CERDIP

*X = A for 5% Output Accuracy, X = B for 10% Output Accuracy.
Ordering information continued on last page.

Typical Operating Circuit

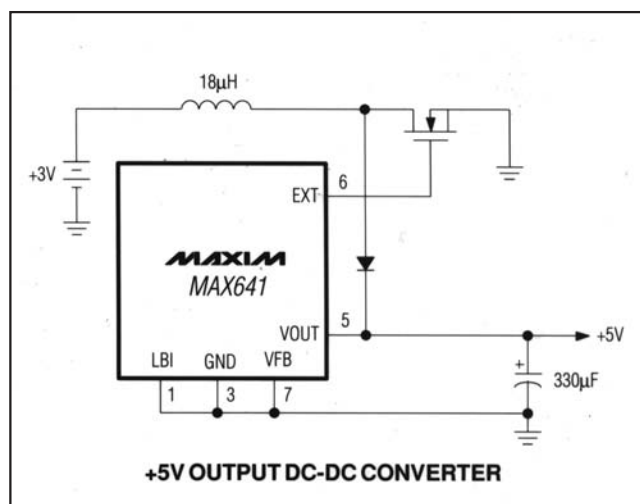

MAXIM

Maxim Integrated Products 1

For pricing, delivery, and ordering information, please contact Maxim/Dallas Direct! at 1-888-629-4642, or visit Maxim's website at www.maxim-ic.com.

Fixed Output 10W CMOS Step-Up Switching Regulators

ABSOLUTE MAXIMUM RATINGS

Supply Voltage, VOUT	+18V	Operating Temperature	
Output Voltage, LX and LBO	+18V	MAX64__C	-40°C to +70°C
Input Voltage, LBI, LBO, VFB, COMP.	-0.3V to (+VOUT + 0.3V)	MAX64__E	-40°C to +85°C
LX Output Current	450mA Peak	MAX64__M	-55°C to +125°C
LBO Output Current	50mA	Storage Temperature	-65°C to +160°C
Power Dissipation		Lead Temperature (Soldering, 10 sec.)	+300°C
Plastic DIP (derate 8.33mW/°C above +50°C)	625mW		
Small Outline (derate 6mW/°C above +50°C)	450mW		
CERDIP (derate 8mW/°C above +50°C)	800mW		

Stresses beyond those listed under "Absolute Maximum Ratings" may cause permanent damage to the device. These are stress ratings only, and functional operation of the device at these or any other conditions beyond those indicated in the operational sections of the specifications is not implied. Exposure to absolute maximum rating conditions for extended periods may affect device reliability.

ELECTRICAL CHARACTERISTICS

(TA = +25°C, unless otherwise noted.)

PARAMETER	SYMBOL	CONDITIONS	MIN	TYP	MAX	UNITS
Operating Voltage	+Vs	Voltage at VOUT Over Temperature	2.0		16.5	V
Start-up Voltage	+Vs	Voltage at VOUT TA = +25°C Over Temperature	1.5 1.8	1.3		V
Supply Current	Is	LX Off, Over Temperature VOUT = +5V VOUT = +12V VOUT = +15V		0.135 0.5 0.75	0.4 2.0 2.5	mA
Reference Voltage (Internal)	VREF	TA = +25°C Over Temperature	1.24 1.20	1.31	1.38 1.42	V
VOUT Voltage (Note 1)		No Load, VFB = GND, Over Temperature				
		MAX641A } 5% Output MAX642A } Accuracy MAX643A }	4.75 11.4 14.25	5.0 12.0 15.0	5.25 12.6 15.75	V
		MAX641B } 10% Output MAX642B } Accuracy MAX643B }	4.5 10.8 13.5	5.0 12.0 15.0	5.5 13.2 16.5	
		Efficiency	With External MOSFET		80	
Line Regulation (Note 1)		0.5VOUT < +Vs < VOUT		0.08		% VOUT
Load Regulation (Note 1)		+Vs = 0.5VOUT, POUT = 0mW to 150mW		0.2		% VOUT

Fixed Output 10W CMOS Step-Up Switching Regulators

MAX641/642/643

PARAMETER	SYMBOL	CONDITIONS	MIN	TYP	MAX	UNITS
Oscillator Frequency	fo	VOUT = +5V MAX641A MAX641B	40 37.5	45 45	50 56.5	kHz
		VOUT = +12V MAX642A MAX642B	45.5 42	50 50	56 62.5	
		VOUT = +15V MAX643A MAX643B	45.5 42	50 50	56 62.5	
Oscillator Frequency Tempco				-60		Hz/°C
Oscillator Duty Cycle		MAX641, VOUT = +5V MAX642, VOUT = +12V MAX643, VOUT = +15V	40 40 40	50 50 50	60 60 60	%
EXT Output Resistance		VOUT = +5V, IOU = ±10mA VOUT = +15V, IOU = ±30mA		140 90		Ω
EXT Switching Time	ton, toff	CL = 330pF VOUT = +5V VOUT = +15V		160 125		ns
LX On Resistance	RON	Ix = 100mA, VOUT = +5V VOUT = +15V		6 3.5	12 7	Ω
LX Leakage Current	IXL	V4 = +16.5V TA = +25°C Over Temperature (C,E) Over Temperature (M)		0.01	1.0 30 100	μA
Diode Forward Voltage	VF	IF = 100mA			1.0	V
VFB Input Bias Current	IFB			0.01	10	nA
Low Battery Threshold	VLBI			1.31		V
Low Battery Input Bias Current	ILBI			0.01	10	nA
Low Battery Output Current	ILBO	V2 = +0.4V, V1 = +1.1V TA = +25°C Over Temperature	0.5	1.0		mA
Low Battery Output Leakage Current	ILBOL	V2 = +16.5V, V1 = +1.4V		0.01	3.0	μA

Note 1: Guaranteed by correlation with DC pulse measurements.

Fixed Output 10W CMOS Step-Up Switching Regulators

Pin Description

PIN	NAME	FUNCTION
1	LBI	Low Battery Input. When the voltage at LBI is lower than the Low Battery Detector threshold (+1.31V), LBO sinks current.
2	LBO	The Low Battery Detector Output is an open drain N-channel MOSFET which sinks current when the LBI is below +1.31V.
3	GND	Ground
4	LX	In low-power applications, LX drives the external inductor with an internal N-channel power MOSFET. LX has a typical output resistance of 6Ω and a peak current rating of 450mA.
5	VOUT	The regulated DC-DC converter output when the internal MOSFET and catch diode are used. When an external diode is used, this pin becomes the supply voltage input pin and is usually connected to the cathode of the external diode.

PIN	NAME	FUNCTION
6	EXT	The drive output for an external power MOSFET or bipolar transistor. EXT swings from GND to VOUT and has approximately 100Ω sink/source impedance. EXT is low when LX is open circuit and high when LX is on.
7	VFB	When VFB is grounded, the DC-DC converter output will be the factory preset value. When an external voltage divider is connected to VFB, this pin becomes the feedback input for adjustable output operation.
8	COMP	The Compensation input is connected to the internal voltage divider which sets the fixed voltage output. In some circuit board layouts, a lead compensation capacitor (100pF to 10nF) connected between VOUT and COMP reduces low-frequency ripple and improves transient response. Ground comp when using an External Voltage divider on VFB.

Typical Operating Characteristics

SUPPLY CURRENT vs. OUTPUT VOLTAGE

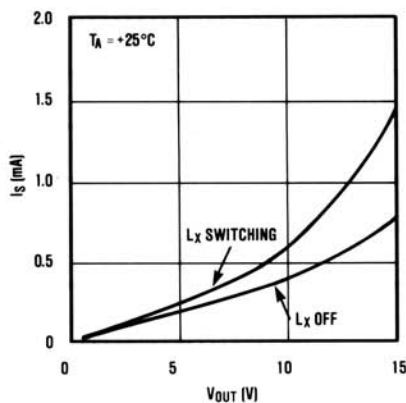

LX OUTPUT CURRENT vs. Vout

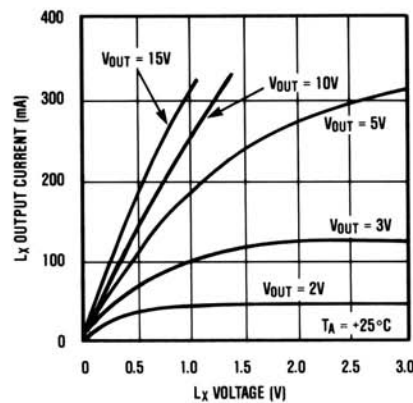

OSCILLATOR FREQUENCY vs. OUTPUT VOLTAGE

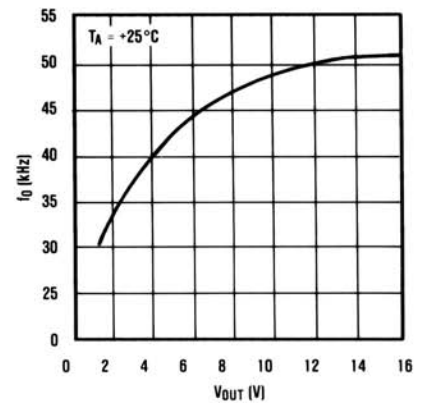

Fixed Output 10W CMOS Step-Up Switching Regulators

MAX641/642/643

Detailed Description

Basic Operation

The operation of the MAX641 series can best be understood by examining the regulating loop of Figure 1. When the output voltage drops below the preset (or externally set) value, the Error Comparator switches high and connects the internal 45kHz Oscillator to the gate of the internal MOSFET and to the EXT output. EXT is typically connected to the gate of an external N-channel power MOSFET. When EXT is activated, the MOSFET turns on and off at the internal clock frequency.

When EXT is high, the MOSFET switches on, and the inductor current increases linearly storing energy in the coil. When EXT switches the MOSFET off, the coil's magnetic field collapses, and the voltage across the inductor reverses sign. The voltage at the anode of the catch diode then rises until the diode is forward biased, delivering power to the output. As the output voltage reaches the desired level, the Error Comparator inhibits EXT until the load discharges the output filter capacitor to less than the desired output level.

Though designed to power an external MOSFET or bipolar transistor, the MAX641 series will also work well in low-power applications (<250mW) with its own internal MOSFET and catch diode. In these applications, the LX output does the current switching and an external capacitor and inductor are all that are needed.

V_{IN}, Bootstrapped Operation

The MAX641/642/643 do not have a V_{IN} pin. Input power to start the DC-DC converter is supplied via the external inductor (and diode, if used) to the V_{OUT} pin. Once the converter has started, it is then powered from its own output. This design ensures that the output MOSFET will have maximum gate drive and, hence, a minimum R_{ON}. It also allows the converter to start at lower input voltages.

V_{IN} Greater Than V_{OUT}

If the regulator's input voltage is more than 1 forward diode drop greater than the desired output voltage, the EXT and LX outputs will not turn on, and the output will no longer be regulated. However, current will be supplied to the load directly through the catch diode. As long as the input is more than 0.6V above the desired output,

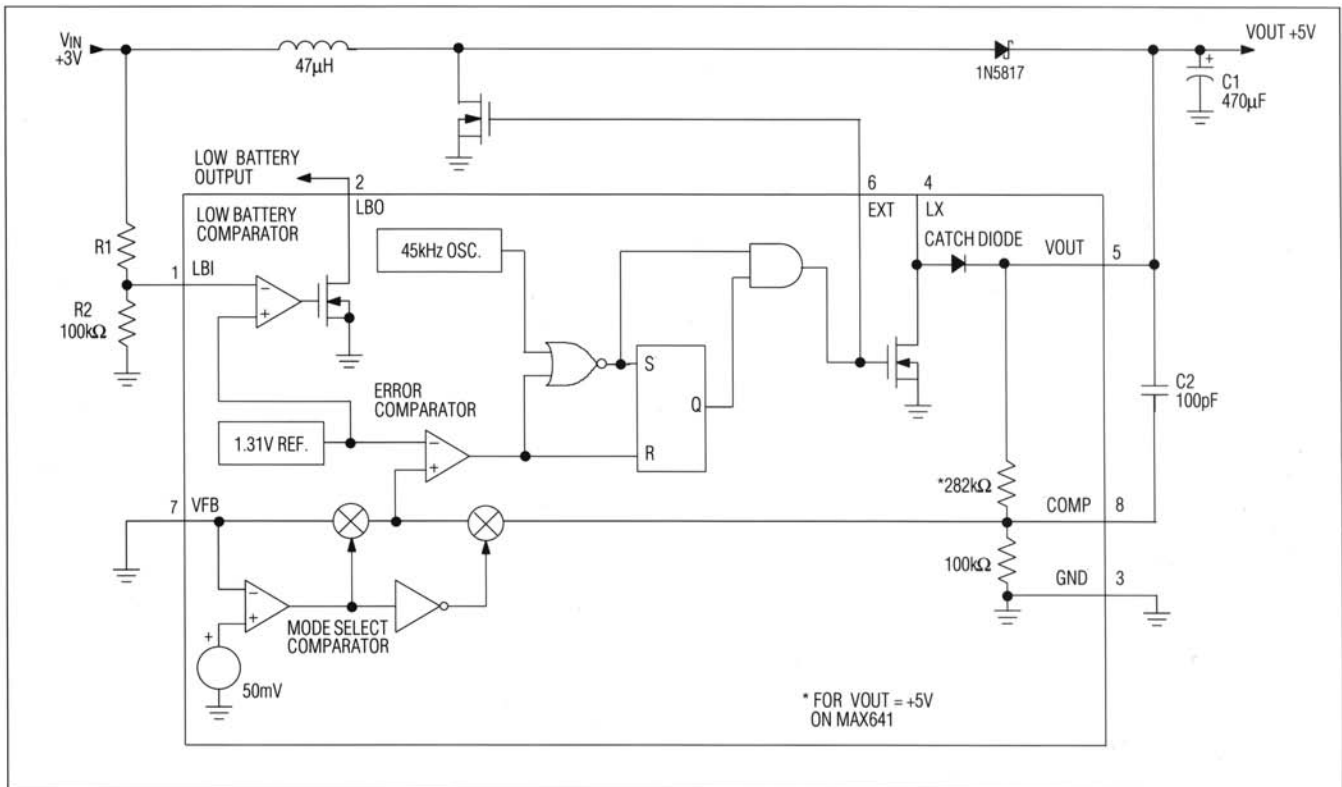

Figure 1. +3V to +5V Converter and Block Diagram for MAX641/642/643

Fixed Output 10W CMOS Step-Up Switching Regulators

the output will equal the input voltage, less the forward drop of the catch diode.

Fixed or Adjustable Output

For operation at one of the preset output voltages (+5V for the MAX641, +12V for MAX642, and +15V for MAX643), VFB is connected to GND, and no external resistors are required.

For other output voltages, a voltage divider is connected to VFB as shown in Figure 2. The output is set by R3 and R4 as follows:

Let R4 be any resistance in the 10kΩ to 10MΩ range, typically 100kΩ, then:

$$R3 = R4 \left(\frac{VOUT}{1.31} - 1 \right)$$

Low Battery Detector

The Low Battery Detector compares the voltage on the Low Battery Input (LBI), with the internal +1.31V bandgap reference. The Low Battery Detector Output (LBO) goes low whenever the input voltage at LBI is less than +1.31V. The Low Battery threshold is set by resistors R1 and R2 (Figure 1).

Let R2 be any resistance in the 10kΩ to 10MΩ range, typically 100kΩ.

$$R1 = R2 \left(\frac{VLB}{1.31V} - 1 \right) \quad \text{(VLB is the desired Low Battery detection voltage)}$$

What Value Of Inductor?

A General Discussion

The converters in this data sheet operate by charging an inductor from a DC input, then discharging the inductor to generate a DC output greater than the input.

The proper inductor for any DC-DC converter depends on three things: the desired output power, the input voltage (or range of input voltage), and the converter's oscillator frequency and duty cycle. The oscillator timing is important because it determines how long the coil will be charged during each cycle. This, along with the input voltage, determines how much energy will be stored in the coil.

The inductor must meet four electrical criteria:

[] **Value-** Low enough inductance so it stores adequate energy at the worst-case, low input voltage.

High enough so excessive and potentially destructive currents are avoided under worst-case high conditions for power-switch transistor on time and high input voltage.

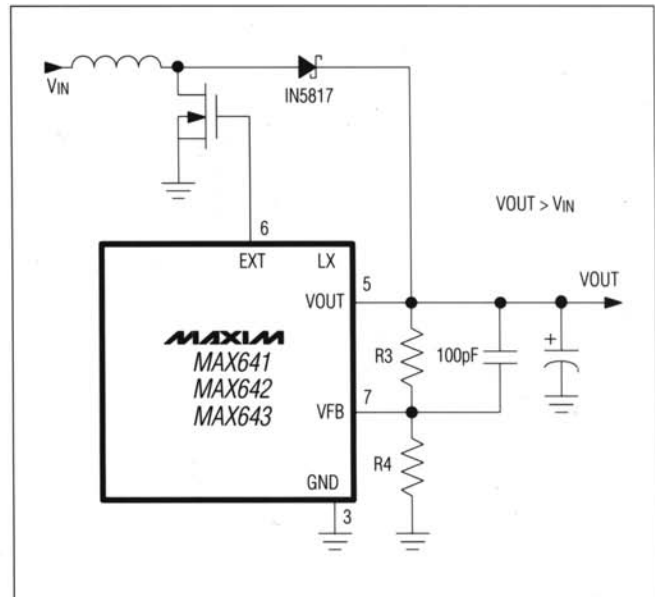

Figure 2. Connections for Adjustable Output Operation

[] **Saturation-** The coil must deliver the correct inductance value at the worst-case, high peak operating current.

[] **EMI-** Electromagnetic interference must not upset nearby circuitry or the regulator IC. Ferrite bobbin types work well for most digital circuits; toroids or pot cores work well for EMI-sensitive analog circuits.

[] **DC resistance-** Winding resistance must be adequately low so efficiency is not affected and self-heating does not occur. Values less than 0.5Ω are usually more than adequate.

Other inductor parameters, such as core loss or self-resonant frequency, are not a factor at the relatively low MAX641/642/643 operating frequency.

Inductor Value- Low Enough?

The problem that bites designs most often, especially in the production or pre-production phase, happens when the inductor value is too high. These units fail to deliver enough load current and exhibit poor load regulation. The worst case is:

- [] Maximum load current
- [] Minimum supply voltage
- [] Maximum inductor value, including tolerance
- [] Maximum on resistance of the switch because it reduces the excitation voltage across the inductor
- [] Worst-case low on time

Fixed Output 10W CMOS Step-Up Switching Regulators

Inductor Value- High Enough?

The inductor value must be high enough so peak currents do not stress the transistor or cause the inductor core to saturate. Odd symptoms can be traced to excessive inductor currents: low efficiency, rattling heat sinks, whining coils, and increased output ripple. Very low inductor values may result in damaged power transistors.

The slope of the inductor current, and therefore the peak value that it reaches in a given on time, is determined by the supply voltage and the inductor value. The worst case occurs at:

- [] Maximum supply voltage
- [] Minimum inductor value, including tolerance
- [] Minimum on resistance of the switch
- [] Low switching frequency (or maximum switch on time)

Inductor Selection

The inductor equations below must be calculated for both worst-case sets of conditions. The final value chosen should be between the minimum value and maximum value calculated. Within these bounds, the value can be adjusted slightly lower for extra load capability or higher for lowest ripple.

$$[1] I_{pk} = \frac{V_{OUT} + V_{DIODE} - V_{IN}}{(0.25)(V_{IN} - V_{SW})} (I_{OUT})$$

$$[2] L = \frac{V_{IN} - V_{SW}}{I_{pk}} (t_{ON})$$

Where V_{SW} is the voltage drop across the switch in the on state. Conservatively, the worst case is about 0.75V max, 0.25V min with $V_{IN} = +15V$ and 1.5V max, 0.5V min with $V_{IN} = +5V$.

Example: A +5V 10% input must be converted to +15V at 15mA. A Schottky diode (1N5817) and a MAX643B are used.

Calculate maximum inductor value allowed:

$$I_{pk} = \frac{15V + 0.4V - 4.5V}{(0.25)(4.5V - 0.75V)} (15mA) = 174mA$$

$$L = \frac{4.5 - 0.75}{174mA} (8\mu s) = 172\mu H$$

Calculate the minimum inductor value allowed:

$I_{pk} = 450mA$ (from table of max ratings; use the power MOSFET max ratings for external transistor circuits)

$$L = \frac{5.5V - 0.25V}{450mA} (12\mu s) = 140\mu H$$

A value of 160 μ H would be a good choice for this application. The "A" grade devices, with tighter oscillator tolerance, allow more output current in a given application.

Application Hints

External MOSFET

An external MOSFET or transistor can be used to drive the inductor in high-power applications. The current handling specifications of the device must match the peak current which flows in the inductor (see Inductor Selection). The only restriction on the size of the external driver is that the EXT output must be able to drive the external device's gate (or base) capacitance at the internal clock rate (45kHz). An external driver may be used to increase operating voltage range of the MAX641/642/643.

Table 2 contains a list of MOSFETs and their manufacturers. Logic level MOSFETs should be used when the supply voltage is less than +5V. Refer to Figures 4 and 5 for circuits requiring external MOSFETs.

Output Filter Capacitor

The MAX641/642/643 output ripple has 2 components which are 90° out of phase. One component results from the change in the stored charge on the filter capacitor with each LX pulse. The other is the product of the capacitor's charge-discharge current and its Equivalent Series Resistance (ESR). With low-cost aluminum electrolytic capacitors, the ESR produced ripple is often larger than that caused by the change in charge. Consequently, high-quality aluminum or tantalum filter capacitors will minimize output ripple, even if smaller capacitance values are used. Best results at a reasonable cost are typically achieved with a high-quality aluminum electrolytic, in the 100 μ F to 500 μ F range, in parallel with a 0.1 μ F ceramic capacitor.

Diodes

When the MAX641/642/643 are used with an external power MOSFET, the internal diode can be used if the peak diode current rating (450mA) and maximum package power dissipation ratings are observed. For higher power circuits, an external Schottky diode such as the 1N5817 (1 Amp) or 1N5821 (3 Amp) should be connected between LX and VOUT in parallel with the internal diode. Although 1N4001s and other general purpose rectifiers are rated for high currents, they are not recommended because their slow turn-on time results in excessive losses and poor efficiency.

Fixed Output 10W CMOS Step-Up Switching Regulators

Bypassing and Compensation

Since the inductor charging current can be relatively large, high currents flow through the ground connection near the MAX641/642/643. To prevent unwanted feedback, the impedance of the ground path must be as low as possible, and a bypass capacitor (10 μ F) should be at the VOUT pin, even if large filter capacitor are used elsewhere in the circuit.

When large values (>50k Ω) are used for the voltage setting resistors (R3 and R4 of Figure 2), stray capacitance at the VFB input can add a "lag" to the feedback response, destabilizing the regulator and causing output

pulses to occur in bursts. This problem can often be avoided by minimizing pin lengths and circuit board trace size at the VFB node. Normal operation with evenly distributed pulses can also be restored by adding a "lead" compensation capacitor (100pF to 10nF) in parallel with R3.

The COMP input allows access to the internal voltage divider so that compensation can also be added when fixed output operation is used. A capacitor connected between VOUT and COMP adds a "lead" to the regulator's response.

Table 1. Representative N-Channel Power MOSFETs

PART NUMBER	PKG.	R _{on} AT (I _{DS} , V _{GS} = X)	V(MAX)	MFG.
IRFD121	4p DIP	0.3 Ω (1.3A, 10V)	60	H/IR
BUZ71A	TO-220	0.12 Ω (6A, 10V)	50	MOT/SI/SM
BUZ21	TO-220	0.1 Ω (9A, 10V)	100	MOT/SI/SM
IRF513	TO-220	0.8 Ω (2A, 10V)	100	H/IR/MOT/SI
IRF530	TO-220	0.18 Ω (8A, 10V)	100	H/IR/MOT/SI
IRF540	TO-220	0.085 Ω (8A, 10V)	100	H/IR/MOT/SI
IRF620	TO-220	0.8 Ω (2.5A, 10V)	200	H/IR/MOT/SI
IRF640	TO-220	0.18 Ω (10A, 10V)	200	H/IR/MOT/SI

Manufacturer Code: H= Harris, IR= International Rectifier, MOT= Motorola, SM= Siemens, SI= Siliconix

N-Channel Logic-Level Power MOSFETs

PART NUMBER	PKG.	R _{on} AT (I _{DS} , V _{GS} = X)	V(MAX)	MFG.
RFP25N06L	TO-220	0.85 Ω (12.5A, 5V)	50	H
RFP12N10L	TO-220	0.20 Ω (6A, 5V)	100	H
PFP15N06L	TO-220	0.14 Ω (7.5A, 5V)	50	H
IRL540	TO-220AB	0.11 Ω (24A, 4V)	100	IR
IRL734	TO-220AB	0.3 Ω (7.8A, 4V)	60	IR
IRZ14	TO-220AB	0.07 Ω (23A, 4V)	60	IR
MTM25N05L	TO-220AB	0.1 Ω (12.5A, 5V)	50	MOT
MTM15N05L	TO-220AB	0.15 Ω (7.5A, 5V)	50	MOT
MTP12N10L	TO-220AB	0.18 Ω (6A, 5V)	100	MOT

Manufacturer Code: H= Harris, IR= International Rectifier, MOT= Motorola

Note: This list does not constitute an endorsement by Maxim Integrated Products and is not intended to be a comprehensive list of all manufacturers of these components.

Fixed Output 10W CMOS Step-Up Switching Regulators

MAX641/642/643

Table 2. Inductance Values for Commonly Encountered Power Supplies (Figure 5)

MAXIM PART NO.	V _{IN} (V)	V _{OUT} (V)	I _{OUT} (mA)	TYP EFF (%)	I _{pk} (A)	PART NO.	INDUCTOR (L)	
							μH	Ω
MAX641	3	5	200	83	1.3	6860-13	100	.10
	3	5	300	80	2.0	6860-09	47	.05
MAX642	5	12	200	91	1.2	6860-08	39	0.05
	5	12	350	89	2	6860-04	18	0.03
	5	12	550	87	3.5	7200-02	12	0.01
MAX643	5	15	100	92	1.2	6860-08	39	0.05
	5	15	150	89	1.5	6860-06	27	0.04
	5	15	225	89	2	6860-04	18	0.03
	5	15	325	85	3.5	7200-02	12	0.01

* Ferrite Bobbin Coils from Caddell-Burns, NY (516) 746-2310

Inductor Saturation

It is important to be sure that the inductor does not saturate, particularly in high-power circuits. Inductor saturation leads to very high current levels through the external boost transistor, causing excessive power dissipation, poor efficiency, and possible damage to the inductor and the external transistor.

Test for saturation by applying the maximum load and the maximum input voltage while monitoring the inductor current with a current probe. The normal inductor current waveform is a sawtooth with a linear current ramp. Saturation creates a nonlinear current waveform with a very rapid increase in current once the inductor saturates.

To ensure that the current rating(s) of the FET(s) is not exceeded, the inductance value of the coil, including the manufacturer's tolerances, should never be lower than that used in the calculations or in Table 2. In addition, to ensure that the core does not saturate, the current rating of the coil should be greater than the peak current, I_{pk}.

Coil resistance has a significant effect on the output current. To increase the output current and raise the overall efficiency, the inductor should have a resistance less than a few tenths of an Ohm.

Inductance Values

Inductance values for commonly encountered power supplies are listed in Table 2. The data in Table 2 refers to the circuit in Figure 5.

Typical Applications

Basic High-Power Hookup

Figure 5 shows the standard circuit configuration for a fixed output step-up DC-DC converter. The output power is determined by the current ratings of the external MOSFET and inductor, as well as, the switching time of the EXT output into the gate capacitance of the MOSFET.

Typical switching times are given in the Electrical Characteristics Table.

Low-Power Step-Up Conversion

In low-power applications, the LX output and internal diode may be used instead of an external MOSFET and diode, as shown in Figure 3. The power handling capability of this circuit is about 250mW. See the MAX631 data sheet for inductor selection information.

High-Voltage Operation

If the external MOSFET or transistor has an adequate voltage rating, the output voltage range of the MAX641/642/643 can be extended (Figure 4). The adjustable output mode must be used (VFB connected to external resistors), and the VOUT pin must be connected to the circuit's INPUT voltage.

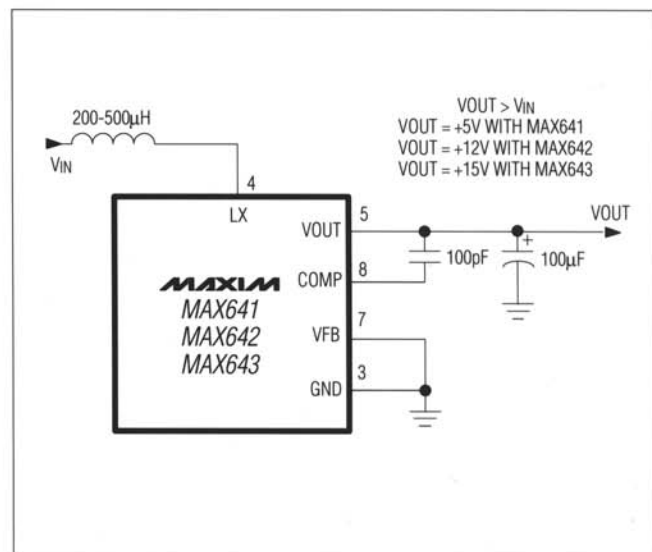

Figure 3. Low-Power, Fixed Output Step-Up Converter Using LX

Fixed Output 10W CMOS Step-Up Switching Regulators

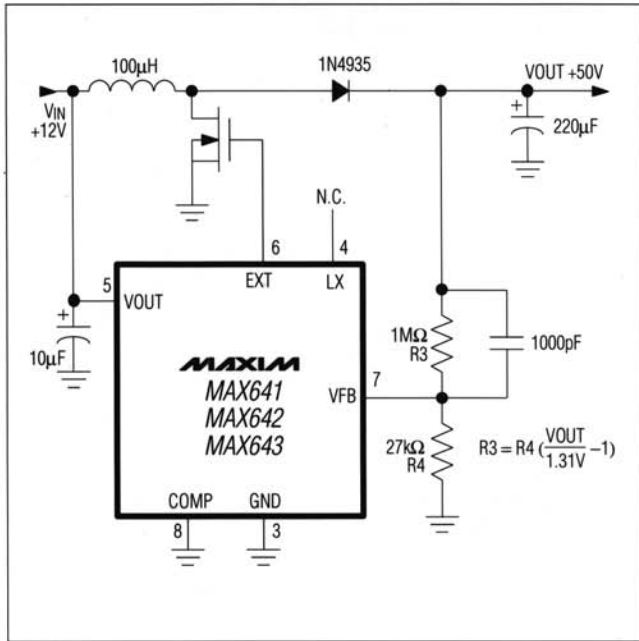

Figure 4. High-Voltage Step-Up Converter

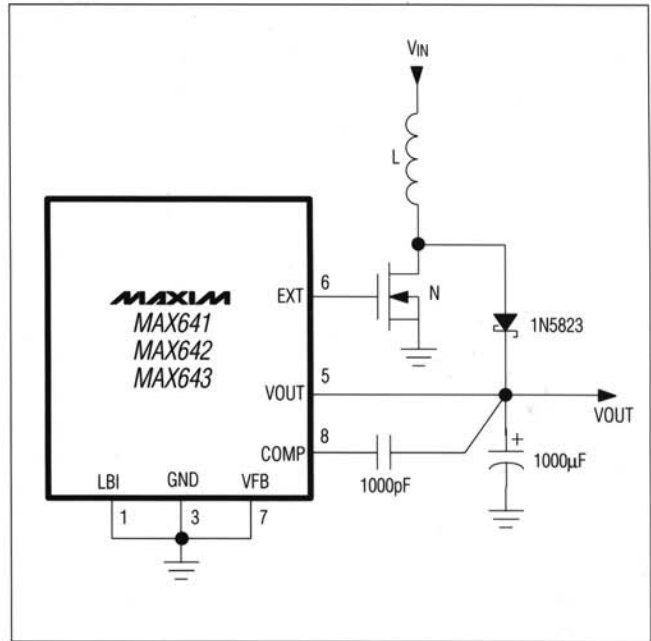

Figure 5. High Output Current Step-Up Converter (See Table 2)

Fixed Output 10W CMOS Step-Up Switching Regulators

MAX641/642/643

Table 3. Maxim DC-DC Converters

PART NUMBER	DESCRIPTION	INPUT VOLTAGE	OUTPUT VOLTAGE	COMMENTS
Low-Power Boost Converters				
MAX630/4193	DC-DC Boost Converter	2V to 16.5V	$V_{OUT} > V_{IN}$	Improved RC4193 2nd source
MAX631	DC-DC Boost Converter	1.5V to 5.6V	+5V	Only 2 external components
MAX632	DC-DC Boost Converter	1.5V to 12.6V	+12V	Only 2 external components
MAX633	DC-DC Boost Converter	1.5V to 15.6V	+15V	Only 2 external components
High-Power Boost Converters				
MAX641	High-Power Boost Converter	1.5V to 5.6V	+5V	Drives external MOSFET
MAX642	High-Power Boost Converter	1.5V to 12.6V	+12V	Drives external MOSFET
MAX643	High-Power Boost Converter	1.5V to 15.6V	+15V	Drives external MOSFET
Low-Voltage Boost Converters				
MAX654	Low-Voltage Boost Converter	1.15V to 5.6V	+5V	Optimized for 1 cell
MAX655	Low-Voltage Boost Converter	1.5V to 5.6V	+5V	Optimized for 2 cells
MAX656	Low-Voltage Boost Converter	1.15V to 5.6V	+5V	Drives external MOSFET
MAX657	Low-Voltage Boost Converter	1.15V to 3.6V	+3V	Optimized for 1 cell
MAX658	Low-Voltage Boost Converter	1.5V to 5.6V	+5V	Drives external MOSFET
MAX659	Low-Voltage Boost Converter	1.5V to 3.6V	+3V	Optimized for 2 cells
Inverting Converters				
MAX634/4391	DC-DC Voltage Inverter	2V to 16.5V	up to -20V	Improved RC4391 2nd source
MAX635	DC-DC Voltage Inverter	2V to 16.5V	-5V	Only 3 external components
MAX636	DC-DC Voltage Inverter	2V to 16.5V	-12V	Only 3 external components
MAX637	DC-DC Voltage Inverter	2V to 16.5V	-15V	Only 3 external components
Step-Down Converter				
MAX638	DC-DC Voltage Stepdown	3V to 16.5V	$V_{OUT} < V_{IN}$	Only 3 external components
Charge-Pump Converters				
MAX680	± Output Charge Pump	2V to 6V	$\pm 2V_{IN}$	4 external capacitors
MAX681	± Output Charge Pump	2V to 6V	$\pm 2V_{IN}$	MAX680 with internal capacitors
ICL7660	Negative Charge Pump	1.5V to 10V	$-V_{IN}$	Not regulated
ICL7662/Si7661	Negative Charge Pump	4.5V to 20V	$-V_{IN}$	Not regulated
Dual Output Converters				
MAX742	Current-Mode Controller	+5V	$\pm 15V/\pm 12V$	Drives external MOSFETs
MAX743	Current-Mode Regulator	+5V	$\pm 15V/\pm 12V$	3W output

Fixed Output 10W CMOS Step-Up Switching Regulators

Chip Topography

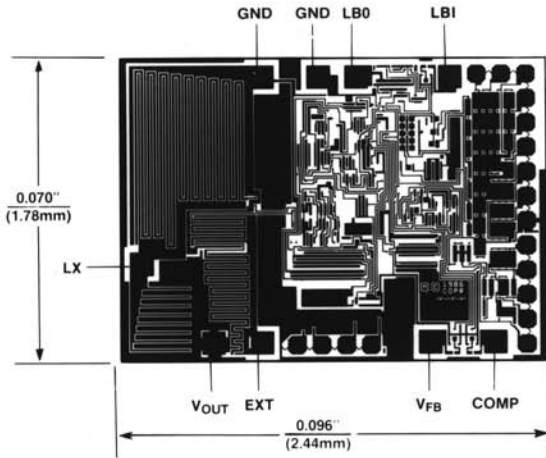

Ordering Information (continued)

PART*	TEMP. RANGE	PIN-PACKAGE
MAX643XCPA	0°C to +70°C	8 Plastic DIP
MAX643XCSEA	0°C to +70°C	8 Narrow SO
MAX643XC/D	0°C to +70°C	8 Dice
MAX643XEPA	-40°C to +85°C	8 Plastic DIP
MAX643XESA	-40°C to +85°C	8 Narrow SO
MAX643XEJA	-40°C to +85°C	8 CERDIP
MAX643XMJA	-55°C to +125°C	8 CERDIP

*X = A for 5% Output Accuracy, X = B for 10% Output Accuracy.

Maxim cannot assume responsibility for use of any circuitry other than circuitry entirely embodied in a Maxim product. No circuit patent licenses are implied. Maxim reserves the right to change the circuitry and specifications without notice at any time.

12 **Maxim Integrated Products, 120 San Gabriel Drive, Sunnyvale, CA 94086 408-737-7600**

Maxim > Products > Power and Battery Management

MAX641, MAX642, MAX643

5V Adjustable, 10W, CMOS, Step-Up, Switching Regulator Controller

QuickView

Technical Documents

Ordering Info

More Information

All

Ordering Information

Notes:

- Other options and links for purchasing parts are listed at: <http://www.maxim-ic.com/sales>.
- Didn't Find What You Need?** Ask our applications engineers. Expert assistance in finding parts, usually within one business day.
- Part number suffixes: T or T&R = tape and reel; + = RoHS/lead-free; # = RoHS/lead-exempt. More: See [Full Data Sheet](#) or [Part Naming Conventions](#).
- * Some packages have variations, listed on the drawing. "PkgCode/Variation" tells which variation the product uses.

Devices: 1-70 of 70

MAX641	Free Sample	Buy	Package: TYPE PINS FOOTPRINT DRAWING CODE/VAR *	Temp	RoHS/Lead-Free? Materials Analysis
MAX641ACJA			Ceramic DIP;8 pin;81 mm Dwg: 21-0045A (PDF) Use pkgcode/variation: J8-2*	0C to +70C	RoHS/Lead-Free: No Materials Analysis
MAX641BCJA			Ceramic DIP;8 pin;81 mm Dwg: 21-0045A (PDF) Use pkgcode/variation: J8-2*	0C to +70C	RoHS/Lead-Free: No Materials Analysis
MAX641AEJA			Ceramic DIP;8 pin;81 mm Dwg: 21-0045A (PDF) Use pkgcode/variation: J8-2*	-40C to +85C	RoHS/Lead-Free: No Materials Analysis
MAX641BEJA			Ceramic DIP;8 pin;81 mm Dwg: 21-0045A (PDF) Use pkgcode/variation: J8-2*	-40C to +85C	RoHS/Lead-Free: No Materials Analysis
MAX641BMJA			Ceramic DIP;8 pin;81 mm Dwg: 21-0045A (PDF) Use pkgcode/variation: J8-2*	-55C to +125C	RoHS/Lead-Free: No Materials Analysis
MAX641AMJA/883B			Ceramic DIP;8 pin;81 mm Dwg: 21-0045A (PDF) Use pkgcode/variation: J8-2*	-55C to +125C	RoHS/Lead-Free: No Materials Analysis
MAX641AMJA			Ceramic DIP;8 pin;81 mm Dwg: 21-0045A (PDF) Use pkgcode/variation: J8-2*	-55C to +125C	RoHS/Lead-Free: No Materials Analysis
MAX641BC/D					RoHS/Lead-Free: See data sheet
MAX641AC/D					RoHS/Lead-Free: See data sheet
MAX641ACPA+			PDIP;8 pin;82 mm Dwg: 21-0043D (PDF) Use pkgcode/variation: P8+2*	0C to +70C	RoHS/Lead-Free: Lead Free Materials Analysis
MAX641AEPA+			PDIP;8 pin;82 mm Dwg: 21-0043D (PDF) Use pkgcode/variation: P8+2*	-40C to +85C	RoHS/Lead-Free: Lead Free Materials Analysis
MAX641BCPA			PDIP;8 pin;82 mm Dwg: 21-0043D (PDF) Use pkgcode/variation: P8-2*	0C to +70C	RoHS/Lead-Free: No Materials Analysis
MAX641ACPA			PDIP;8 pin;82 mm Dwg: 21-0043D (PDF) Use pkgcode/variation: P8-2*	0C to +70C	RoHS/Lead-Free: No Materials Analysis

MAX641BEPA			PDIP;8 pin;82 mm Dwg: 21-0043D (PDF) Use pkgcode/variation: P8-2*	-40C to +85C	RoHS/Lead-Free: No Materials Analysis
MAX641AEPA			PDIP;8 pin;82 mm Dwg: 21-0043D (PDF) Use pkgcode/variation: P8-2*	-40C to +85C	RoHS/Lead-Free: No Materials Analysis
MAX641ACSA+T			SOIC;8 pin;31 mm Dwg: 21-0041B (PDF) Use pkgcode/variation: S8+4*	0C to +70C	RoHS/Lead-Free: Lead Free Materials Analysis
MAX641ACSA			SOIC;8 pin;31 mm Dwg: 21-0041B (PDF) Use pkgcode/variation: S8-4*	0C to +70C	RoHS/Lead-Free: No Materials Analysis
MAX641BCSA			SOIC;8 pin;31 mm Dwg: 21-0041B (PDF) Use pkgcode/variation: S8-4*	0C to +70C	RoHS/Lead-Free: No Materials Analysis
MAX641ACSA-T			SOIC;8 pin;31 mm Dwg: 21-0041B (PDF) Use pkgcode/variation: S8-4*	0C to +70C	RoHS/Lead-Free: No Materials Analysis
MAX641ACSA+			SOIC;8 pin;31 mm Dwg: 21-0041B (PDF) Use pkgcode/variation: S8+4*	0C to +70C	RoHS/Lead-Free: Lead Free Materials Analysis
MAX641AESA+			SOIC;8 pin;31 mm Dwg: 21-0041B (PDF) Use pkgcode/variation: S8+4*	-40C to +85C	RoHS/Lead-Free: Lead Free Materials Analysis
MAX641AESA+T			SOIC;8 pin;31 mm Dwg: 21-0041B (PDF) Use pkgcode/variation: S8+4*	-40C to +85C	RoHS/Lead-Free: Lead Free Materials Analysis
MAX641AESA			SOIC;8 pin;31 mm Dwg: 21-0041B (PDF) Use pkgcode/variation: S8-4*	-40C to +85C	RoHS/Lead-Free: No Materials Analysis
MAX641AESA-T			SOIC;8 pin;31 mm Dwg: 21-0041B (PDF) Use pkgcode/variation: S8-4*	-40C to +85C	RoHS/Lead-Free: No Materials Analysis
MAX641BESA			SOIC;8 pin;31 mm Dwg: 21-0041B (PDF) Use pkgcode/variation: S8-4*	-40C to +85C	RoHS/Lead-Free: No Materials Analysis
MAX642	Free Sample	Buy	Package: TYPE PINS FOOTPRINT DRAWING CODE/VAR *	Temp	RoHS/Lead-Free? Materials Analysis
MAX642ACJA			Ceramic DIP;8 pin;81 mm Dwg: 21-0045A (PDF) Use pkgcode/variation: J8-2*	0C to +70C	RoHS/Lead-Free: No Materials Analysis
MAX642BCJA			Ceramic DIP;8 pin;81 mm Dwg: 21-0045A (PDF) Use pkgcode/variation: J8-2*	0C to +70C	RoHS/Lead-Free: No Materials Analysis
MAX642BEJA			Ceramic DIP;8 pin;81 mm Dwg: 21-0045A (PDF) Use pkgcode/variation: J8-2*	-40C to +85C	RoHS/Lead-Free: No Materials Analysis
MAX642AEJA			Ceramic DIP;8 pin;81 mm Dwg: 21-0045A (PDF) Use pkgcode/variation: J8-2*	-40C to +85C	RoHS/Lead-Free: No Materials Analysis
MAX642BMJA			Ceramic DIP;8 pin;81 mm Dwg: 21-0045A (PDF) Use pkgcode/variation: J8-2*	-55C to +125C	RoHS/Lead-Free: No Materials Analysis
MAX642AMJA			Ceramic DIP;8 pin;81 mm Dwg: 21-0045A (PDF) Use pkgcode/variation: J8-2*	-55C to +125C	RoHS/Lead-Free: No Materials Analysis
MAX642AMJA/883B			Ceramic DIP;8 pin;81 mm Dwg: 21-0045A (PDF) Use pkgcode/variation: J8-2*	-55C to +125C	RoHS/Lead-Free: No Materials Analysis
MAX642AC/D					RoHS/Lead-Free: See data sheet
MAX642AEPA+			PDIP;8 pin;82 mm Dwg: 21-0043D (PDF) Use pkgcode/variation: P8+2*	-40C to +85C	RoHS/Lead-Free: Lead Free Materials Analysis
MAX642ACPA+			PDIP;8 pin;82 mm Dwg: 21-0043D (PDF) Use pkgcode/variation: P8+2*	0C to +70C	RoHS/Lead-Free: Lead Free Materials Analysis

MAX642BCPA			PDIP;8 pin;82 mm Dwg: 21-0043D (PDF) Use pkgcode/variation: P8-2*	0C to +70C	RoHS/Lead-Free: No Materials Analysis
MAX642ACPA			PDIP;8 pin;82 mm Dwg: 21-0043D (PDF) Use pkgcode/variation: P8-2*	0C to +70C	RoHS/Lead-Free: No Materials Analysis
MAX642BEPA			PDIP;8 pin;82 mm Dwg: 21-0043D (PDF) Use pkgcode/variation: P8-2*	-40C to +85C	RoHS/Lead-Free: No Materials Analysis
MAX642AEPA			PDIP;8 pin;82 mm Dwg: 21-0043D (PDF) Use pkgcode/variation: P8-2*	-40C to +85C	RoHS/Lead-Free: No Materials Analysis
MAX642ACSA+			SOIC;8 pin;31 mm Dwg: 21-0041B (PDF) Use pkgcode/variation: S8+4*	0C to +70C	RoHS/Lead-Free: Lead Free Materials Analysis
MAX642ACSA+T			SOIC;8 pin;31 mm Dwg: 21-0041B (PDF) Use pkgcode/variation: S8+4*	0C to +70C	RoHS/Lead-Free: Lead Free Materials Analysis
MAX642AESA+			SOIC;8 pin;31 mm Dwg: 21-0041B (PDF) Use pkgcode/variation: S8+4*	-40C to +85C	RoHS/Lead-Free: Lead Free Materials Analysis
MAX642AESA+T			SOIC;8 pin;31 mm Dwg: 21-0041B (PDF) Use pkgcode/variation: S8+4*	-40C to +85C	RoHS/Lead-Free: Lead Free Materials Analysis
MAX642BCSA			SOIC;8 pin;31 mm Dwg: 21-0041B (PDF) Use pkgcode/variation: S8-4*	0C to +70C	RoHS/Lead-Free: No Materials Analysis
MAX642ACSA-T			SOIC;8 pin;31 mm Dwg: 21-0041B (PDF) Use pkgcode/variation: S8-4*	0C to +70C	RoHS/Lead-Free: No Materials Analysis
MAX642ACSA			SOIC;8 pin;31 mm Dwg: 21-0041B (PDF) Use pkgcode/variation: S8-4*	0C to +70C	RoHS/Lead-Free: No Materials Analysis
MAX642AESA			SOIC;8 pin;31 mm Dwg: 21-0041B (PDF) Use pkgcode/variation: S8-4*	-40C to +85C	RoHS/Lead-Free: No Materials Analysis
MAX642AESA-T			SOIC;8 pin;31 mm Dwg: 21-0041B (PDF) Use pkgcode/variation: S8-4*	-40C to +85C	RoHS/Lead-Free: No Materials Analysis
MAX642BESA			SOIC;8 pin;31 mm Dwg: 21-0041B (PDF) Use pkgcode/variation: S8-4*	-40C to +85C	RoHS/Lead-Free: No Materials Analysis
MAX643	Free Sample	Buy	Package: TYPE PINS FOOTPRINT DRAWING CODE/VAR *	Temp	RoHS/Lead-Free? Materials Analysis
MAX643AEJA			Ceramic DIP;8 pin;81 mm Dwg: 21-0045A (PDF) Use pkgcode/variation: J8-2*	-40C to +85C	RoHS/Lead-Free: No Materials Analysis
MAX643BEJA			Ceramic DIP;8 pin;81 mm Dwg: 21-0045A (PDF) Use pkgcode/variation: J8-2*	-40C to +85C	RoHS/Lead-Free: No Materials Analysis
MAX643AMJA			Ceramic DIP;8 pin;81 mm Dwg: 21-0045A (PDF) Use pkgcode/variation: J8-2*	-55C to +125C	RoHS/Lead-Free: No Materials Analysis
MAX643BMJA			Ceramic DIP;8 pin;81 mm Dwg: 21-0045A (PDF) Use pkgcode/variation: J8-2*	-55C to +125C	RoHS/Lead-Free: No Materials Analysis
MAX643AC/D					RoHS/Lead-Free: See data sheet
MAX643AEPA+			PDIP;8 pin;82 mm Dwg: 21-0043D (PDF) Use pkgcode/variation: P8+2*	-40C to +85C	RoHS/Lead-Free: Lead Free Materials Analysis
MAX643ACPA			PDIP;8 pin;82 mm Dwg: 21-0043D (PDF) Use pkgcode/variation: P8-2*	0C to +70C	RoHS/Lead-Free: No Materials Analysis
MAX643BCPA			PDIP;8 pin;82 mm Dwg: 21-0043D (PDF) Use pkgcode/variation: P8-2*	0C to +70C	RoHS/Lead-Free: No Materials Analysis

MAX643ACPA+			PDIP;8 pin;82 mm Dwg: 21-0043D (PDF) Use pkgcode/variation: P8+2*	0C to +70C	RoHS/Lead-Free: Lead Free Materials Analysis
MAX643BEPA			PDIP;8 pin;82 mm Dwg: 21-0043D (PDF) Use pkgcode/variation: P8-2*	-40C to +85C	RoHS/Lead-Free: No Materials Analysis
MAX643AEPA			PDIP;8 pin;82 mm Dwg: 21-0043D (PDF) Use pkgcode/variation: P8-2*	-40C to +85C	RoHS/Lead-Free: No Materials Analysis
MAX643ACSA+T			SOIC;8 pin;31 mm Dwg: 21-0041B (PDF) Use pkgcode/variation: S8+4*	0C to +70C	RoHS/Lead-Free: Lead Free Materials Analysis
MAX643ACSA+			SOIC;8 pin;31 mm Dwg: 21-0041B (PDF) Use pkgcode/variation: S8+4*	0C to +70C	RoHS/Lead-Free: Lead Free Materials Analysis
MAX643AESA+			SOIC;8 pin;31 mm Dwg: 21-0041B (PDF) Use pkgcode/variation: S8+4*	-40C to +85C	RoHS/Lead-Free: Lead Free Materials Analysis
MAX643AESA+T			SOIC;8 pin;31 mm Dwg: 21-0041B (PDF) Use pkgcode/variation: S8+4*	-40C to +85C	RoHS/Lead-Free: Lead Free Materials Analysis
MAX643ACSA			SOIC;8 pin;31 mm Dwg: 21-0041B (PDF) Use pkgcode/variation: S8-4*	0C to +70C	RoHS/Lead-Free: No Materials Analysis
MAX643ACSA-T			SOIC;8 pin;31 mm Dwg: 21-0041B (PDF) Use pkgcode/variation: S8-4*	0C to +70C	RoHS/Lead-Free: No Materials Analysis
MAX643BCSA			SOIC;8 pin;31 mm Dwg: 21-0041B (PDF) Use pkgcode/variation: S8-4*	0C to +70C	RoHS/Lead-Free: No Materials Analysis
MAX643AESA			SOIC;8 pin;31 mm Dwg: 21-0041B (PDF) Use pkgcode/variation: S8-4*	-40C to +85C	RoHS/Lead-Free: No Materials Analysis
MAX643BESA			SOIC;8 pin;31 mm Dwg: 21-0041B (PDF) Use pkgcode/variation: S8-4*	-40C to +85C	RoHS/Lead-Free: No Materials Analysis
MAX643AESA-T			SOIC;8 pin;31 mm Dwg: 21-0041B (PDF) Use pkgcode/variation: S8-4*	-40C to +85C	RoHS/Lead-Free: No Materials Analysis

Didn't Find What You Need?

- [Next Day Product Selection Assistance from Applications Engineers](#)
- [Parametric Search](#)
- [Applications Help](#)

QuickView

Description
Key Features
Applications/Uses
[Key Specifications](#)
Diagram

Technical Documents

[Data Sheet](#)
[Application Notes](#)
[Design Guides](#)
Engineering Journals
[Reliability Reports](#)
Software/Models
Evaluation Kits

Ordering Info

Price and Availability
Samples
Buy Online
Package Information
Lead-Free Information

More Information

Related Products
[Notes and Comments](#)
Evaluation Kits

Document Ref.: 19-0920; Rev 0; 1999-03-01
This page last modified: 2005-07-08

[CONTACT US: SEND US AN EMAIL](#)