



POWERED BY

Panasonic Batteries

ENERGY CATALOG

A Comprehensive Guide by Product Grouping and Part Number for Panasonic OEM Batteries



Lithium Primary



Lithium Ion



Nickel Metal Hydride



Lithium Rechargeable



VRLA



Alkaline

Make Your Product Powered by Panasonic

Panasonic ideas for life



POWERED BY

Panasonic Batteries

Panasonic is a leading supplier of batteries offering advanced cell manufacturing and product technologies, superior quality, and one of the broadest lines of primary and rechargeable batteries in the industry. Panasonic's product line includes Lithium-Ion, Lithium coin, Lithium primary cylindrical, Nickel Metal Hydride, Valve Regulated Lead Acid and Alkaline batteries.

Our batteries meet multiple market needs and are ideal for a variety of consumer, commercial and industrial portable power applications. Examples include: power tools, high powered flashlights, medical and dental equipment, uninterruptable power systems, wireless security, and RFID applications among others.

Please refer to the Panasonic OEM battery website at www.panasonic.com/industrial/batteries-oem to download the latest information or send in an e-mail request to oembatteries@us.panasonic.com.

Contents

LITHIUM ION

1

Panasonic rechargeable lithium ion batteries feature high energy density, high capacity, light weight and high power in both cylindrical and prismatic styles.

NICKEL METAL HYDRIDE

2

Developed to meet the requirement for increasingly higher levels of energy demanded by today's electronic products, our NiMH batteries can offer up to three times the capacity of the same size standard Nickel Cadmium batteries.

LITHIUM RECHARGEABLE COIN

3-4

Small component size rechargeable coin cell batteries for memory backup applications and main power sources in small electronic devices. Available in two product variations.

LITHIUM PRIMARY COIN

5-7

3V Poly-carbonmonofluoride (BR) and Manganese Dioxide (CR) batteries for a variety of applications. Special versions of the BR series are also available with wider operating temperatures than the standard product.

LITHIUM PRIMARY CYLINDRICAL

8-9

Poly-carbonmonofluoride (BR) and Manganese Dioxide (CR) cylindrical batteries and user replaceable photo batteries.

VALVE REGULATED LEAD ACID

10-11

Panasonic's tough valve regulated lead acid (VRLA) rechargeable batteries are designed to provide outstanding performance in withstanding overcharge, overdischarge, and resisting vibration and shock.

ALKALINE

12

Our popular alkaline batteries are designed to support industrial strength applications and are packaged for volume purchases.

Lithium Ion Batteries

GENERAL DESCRIPTION

Panasonic rechargeable lithium ion batteries feature high energy density, high capacity, light weight and high power in both cylindrical and prismatic styles.

Panasonic lithium ion batteries provide up to 3.6V per cell, so fewer batteries are required to power an application compared to conventional nickel cadmium and nickel metal hydride batteries.

Notice to readers: In order to ensure the use of properly designed safety circuits with Lithium ion battery packs, Panasonic lithium ion cells are not sold as "off the shelf" products and can only be assembled into packs by authorized pack assembly centers that have been approved for Lithium ion pack design and assembly.

All Panasonic Lithium Ion batteries are covered by the Rechargeable Battery Recycling Corporation's (RBRC) recycling program.

FEATURES

- High energy density
- High capacity
- Light weight
- Over 500 cycles

APPLICATIONS

- Digital cameras
- Cellular phones
- Notebook PC's
- Portable devices



CYLINDRICAL TYPE

Model Number*	Nominal Voltage (V)	Typical ¹ Capacity (mAh)	Dimensions		Weight oz. (g)
			Diameter inch (mm)	Height inch (mm)	
CGR18650CG	3.6	2250	0.73 ^{+0.03} (18.6 ^{+0.7})	2.57 ^{+0.04} (65.2 ^{+1.0})	1.55 (44)
NCR18650	3.6	2900	0.73 ^{+0.03} (18.6 ^{+0.7})	2.57 ^{+0.04} (65.2 ^{+1.0})	1.56 (44.5)
NCR18500	3.6	2000	0.73 ^{+0.03} (18.6 ^{+0.8})	1.97 ^{+0.04} (50.0 ^{+1.0})	1.18 (33.5)

PRISMATIC TYPE - ALUMINUM CASE

Model Number*	Nominal Voltage (V)	Typical ¹ Capacity (mAh)	Dimensions			Weight oz. (g)
			Width inch (mm)	Height inch (mm)	Thickness ² inch (mm)	
CGA103450A	3.7	1950	1.34 ^{+0.02} (34.0 ^{+0.6})	1.97 ^{+0.04} (50.0 ^{+1.0})	0.41 ^{+0.02} (10.5 ^{+0.6})	1.38 (39)

HIGH RATE CYLINDRICAL TYPE

Model Number*	Nominal Voltage (V)	Typical ¹ Capacity (mAh)	Dimensions		Weight oz. (g)
			Diameter inch (mm)	Height inch (mm)	
CGR26650A	3.6	2650	1.04 ^{+0.03} (26.5 ^{+0.7})	2.57 ^{+0.04} (65.2 ^{+1.0})	3.2 (90)
CGR26650B	3.6	3300	1.04 ^{+0.03} (26.5 ^{+0.7})	2.57 ^{+0.04} (65.2 ^{+1.0})	3.2 (90)
CGR18650KA	3.6	1750	0.73 ^{+0.03} (18.6 ^{+0.7})	2.57 ^{+0.04} (65.2 ^{+1.0})	1.55 (44)
CGR18650CH	3.6	2250	0.73 ^{+0.03} (18.6 ^{+0.7})	2.57 ^{+0.04} (65.2 ^{+1.0})	1.55 (44)
CGR18650K	3.6	1650	0.73 ^{+0.03} (18.6 ^{+0.7})	2.57 ^{+0.04} (65.2 ^{+1.0})	1.55 (47)

1. 4.2V charge.

2. Thickness at time of shipment.

*Model numbers may change due to capacity upgrades. Check our website for most recent information and specifications on Lithium Ion cells.

Nickel Metal Hydride Batteries



GENERAL DESCRIPTION

Panasonic Nickel-Metal Hydride batteries were developed to meet the requirement for increasingly higher levels of energy demanded by today's electronic products. Our Nickel-Metal Hydride batteries can offer up to three times the capacity of the same size standard Nickel Cadmium batteries. Due to their increased capacity and energy density features, users can expect a longer time between charges and longer running time.

All Panasonic Nickel Metal Hydride batteries are covered by the Rechargeable Battery Recycling Corporation's (RBRC) recycling program.



FEATURES

- High energy density
- Rapid charge
- Excellent cycle life
- Excellent discharge characteristics

APPLICATIONS

- Two-way radios
 - Standby / Back Up
 - Test Equipment
 - Power tools
 - R/C hobby
 - Digital cameras
- Applications where high-energy and small size are critical*

CYLINDRICAL TYPE									
Model Number	Size	Nominal Voltage (V)	Discharge Capacity ⁵		Rapid Charge		Dimensions		Approximate Weight oz.(g)
			Average ⁴ (mAh)	Minimum (mAh)	Current (mA)	Hours (h)	Diameter inch (mm)	Height inch (mm)	
HHR60AAAH ¹	AAA	1.2	550	500	250	2.4*	0.41 ^{+0.03} (10.5 ^{+0.7})	1.75 ^{+0.04} (44.5 ^{+1.0})	0.46 (13)
HHR70AAAJ	AAA	1.2	730	700	700	1.2	0.41 ^{+0.03} (10.5 ^{+0.7})	1.75 ^{+0.04} (44.5 ^{+1.0})	0.42 (12)
HHR75AAAB	AAA	1.2	730	700	450	1.7	0.41 ^{+0.03} (10.5 ^{+0.7})	1.75 ^{+0.04} (44.5 ^{+1.0})	0.42 (12)
HHR120AA	4/5AA	1.2	1220	1150	1200	1.2	0.57 ^{+0.03} (14.5 ^{+0.7})	1.69 ^{+0.04} (43.0 ^{+1.0})	0.81 (23)
HHR150AA	AA	1.2	1580	1500	1500	1.2	0.57 ^{+0.03} (14.5 ^{+0.7})	1.97 ^{+0.04} (50.0 ^{+1.0})	0.92 (26)
HHR210AAB	AA	1.2	2080	2000	1200	2.0	0.57 ^{+0.03} (14.5 ^{+0.7})	1.99 ^{+0.05} (50.5 ^{+1.0})	1.02 (29)
HHR200A	4/5A	1.2	2040	2000	1700	1.4	0.67 ^{+0.03} (17.0 ^{+0.7})	1.69 ^{+0.06} (43.0 ^{+1.5})	1.13 (32)
HHR210A	A	1.2	2200	2100	2100	1.2	0.67 ^{+0.03} (17.0 ^{+0.7})	1.97 ^{+0.06} (50.0 ^{+1.5})	1.34 (38)
HHR210AH ¹	A	1.2	2050	1900	1000	2.3*	0.67 ^{+0.03} (17.0 ^{+0.7})	1.97 ^{+0.06} (50.0 ^{+1.5})	1.30 (36)
HHR380A	L-A	1.2	3800	3700	2000	dT/dt*	0.67 ^{+0.03} (17.0 ^{+0.7})	2.64 ^{+0.06} (67.0 ^{+1.5})	1.87 (53)
HHR330APH	18670(L-Fat-A)	1.2	3300	3200	1650	2.4*	0.72 ^{+0.03} (18.2 ^{+0.7})	2.64 ^{+0.06} (67.0 ^{+1.5})	2.12 (60)
HHR370AH ¹	18670(L-Fat-A)	1.2	3700	3500	—	—	0.72 ^{+0.03} (18.2 ^{+0.7})	2.64 ^{+0.06} (67.0 ^{+1.5})	2.12 (60)
HHR450A ²	18670(L-Fat-A)	1.2	4500	4200	2000	dT/dt*	0.72 ^{+0.03} (18.2 ^{+0.7})	2.64 ^{+0.06} (67.0 ^{+1.5})	2.12 (60)
HHR200SCP ³	4/5SC	1.2	2100	1900	2000	1.2	0.91 ^{+0.04} (23.0 ^{+1.0})	1.34 ^{+0.06} (34.0 ^{+1.5})	1.50 (42)
HHR250SCH ¹	SC	1.2	2650	2500	1250	2.4	0.91 ^{+0.04} (23.0 ^{+1.0})	1.69 ^{+0.06} (43.0 ^{+1.5})	1.94 (55)
HHR260SCP ³	SC	1.2	2600	2450	2600	1.2	0.91 ^{+0.04} (23.0 ^{+1.0})	1.69 ^{+0.06} (43.0 ^{+1.5})	1.94 (55)
HHR300SCP ³	SC	1.2	3050	2800	3000	1.2	0.91 ^{+0.04} (23.0 ^{+1.0})	1.69 ^{+0.06} (43.0 ^{+1.5})	2.01 (57)
HHR300CH ¹	C	1.2	3300	3000	1500	2.4	1.02 ^{+0.04} (25.8 ^{+1.0})	1.97 ^{+0.06} (50.0 ^{+1.5})	2.82 (80)

1. H Type: Improved low rate charge characteristics at higher temperatures. Ideal for back-up applications (with appropriate charge control circuitry).

2. Mainly for low drain, extended run time applications.

3. Mainly for high drain applications such as power tools.

4. For reference only.

5. After charging at 0.1It for 16 hours, discharging at 0.2It

Note: /B=extended positive terminal (button top).

*Please consult Panasonic for details of dT/dt

Lithium Rechargeable Coin Batteries

VANADIUM RECHARGEABLE LITHIUM BATTERIES (VL SERIES)

MANGANESE RECHARGEABLE LITHIUM BATTERIES (ML SERIES)

GENERAL DESCRIPTION

Panasonic vanadium rechargeable lithium batteries are compact, high energy secondary batteries that have nearly twice the energy of conventional button-shaped Ni-Cd batteries.

FEATURES

- One high-voltage battery can serve your back-up needs
- Months of continuous use as a back-up
- Superior reliability; withstands overcharging and overdischarging



VL COIN CELLS

Model Number	Electrical Characteristics 20°C (68°F)		Recommended Drain Standard (mA)	Dimensions (Max.)		
	Nominal Voltage (V)	*Nominal Capacity (mAh)		Diameter inch (mm)	Height inch (mm)	Weight oz. (g)
VL621	3.0	1.5	0.01	0.27(6.8)	0.08(2.1)	0.01(0.3)
VL1220	3.0	7.0	0.03	0.49(12.5)	0.08(2.0)	0.03(0.8)
VL2020	3.0	20.0	0.07	0.79(20.0)	0.08(2.0)	0.07(2.2)
VL2320	3.0	30.0	0.10	0.91(23.0)	0.08(2.0)	0.09(2.7)
VL2330	3.0	50.0	0.10	0.91(23.0)	0.12(3.0)	0.12(3.5)
VL3032	3.0	100.0	0.20	1.18(30.0)	0.13(3.2)	0.22(6.2)

* Nominal capacity is based on a standard drain and cut off voltage down to 2.5V at 20°C (68°F).

APPLICATIONS

- RTC backup
- Memory cards
- Personal computers
- Sequencers
- Telephones
- Tuners
- Video cameras

GENERAL DESCRIPTION

These super compact lithium secondary batteries feature a new configuration in which a manganese compound oxide is used for the positive electrode, and a lithium/aluminum alloy for the electrode.

FEATURES

- Charge at voltage levels under 3V
- Large capacity for hour-after-hour back-up
- Excellent withstand voltage, overcharge and overdischarge withstanding characteristics



ML COIN CELLS

Model Number	Electrical Characteristics 20°C (68°F)		Recommended Drain Standard (mA)	Dimensions (Max.)		
	Nominal Voltage (V)	*Nominal Capacity (mAh)		Diameter inch (mm)	Height inch (mm)	Weight oz. (g)
ML414 ¹	3.0	1.2	0.005	0.19(4.8)	0.06(1.4)	0.003(0.09)
ML421	3.0	2.3	0.005	0.19(4.8)	0.08(2.1)	0.004(0.11)
ML614 ¹	3.0	3.4	0.01	0.27(6.8)	0.06(1.4)	0.006(0.16)
ML621 ¹	3.0	5.0	0.01	0.27(6.8)	0.08(2.1)	0.008(0.23)
ML920	3.0	11.0	0.03	0.37(9.5)	0.08(2.0)	0.014(0.4)
ML1220	3.0	17.0	0.03	0.49(12.5)	0.08(2.0)	0.03(0.8)
ML2020	3.0	45.0	0.12	0.79(20.0)	0.08(2.0)	0.078(2.2)

* Nominal capacity shown is based on standard drain and cut off voltage down to 2.0V at 20°C (68°F)

¹ Available as a bare cell.

APPLICATIONS

Power source for backing up memory data in:

- Mobile telephones
- Memory cards
- Other small-size communications devices

Lithium Rechargeable Coin Batteries

COIN CELL TAB CONFIGURATIONS

Model Number	Tab Type		Configuration Type
	With Insulation Wrap	Without Insulation Wrap	
VL TYPE			
VL621		/DN	F
VL1220	/HFN		H
VL1220	/VCN		V
VL1220	/FCN		F
VL2020	/VCN		V
VL2020	/HFN		H
VL2320	/VCN		V
VL2320	/HFN		H
VL2320	/F2N		F
VL2330	/VCN		V
VL2330	/HFN		H
VL2330	/F3N		F
VL3032	/GUFN		G
VL3032	/F2N		F

Model Number	Tab Type		Configuration Type
	With Insulation Wrap	Without Insulation Wrap	
ML TYPE			
ML414 ¹		ML-414S/DN	F
ML421	Contact Panasonic for details on available tab configurations.		
ML614 ¹		ML-614S/FN	F
ML621 ¹		ML-621S/DN	F
ML920		ML-920S/DN	F
ML1220	F1AN		F
ML1220	V1AN		V
ML2020	G1AN		G
ML2020	H1CN		H
ML2020	V1AN		V

¹ Also available as a bare cell.

Note: Please refer to the Panasonic website for exact tab dimensions.

Please contact Panasonic for requests on custom tab configurations.
Minimum order requirements may apply.

TYPICAL TAB CONFIGURATIONS

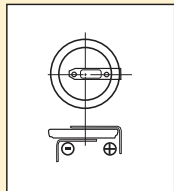

H Type

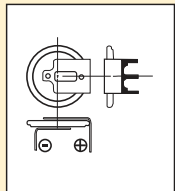

G Type

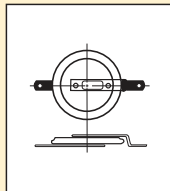

F Type

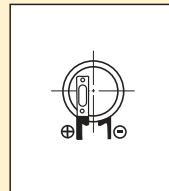

V Type

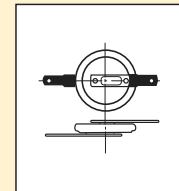

T Type

Lithium Primary Coin Batteries

POLY-CARBONMONOFLUORIDE LITHIUM BATTERIES (BR SERIES)

MANGANESE DIOXIDE LITHIUM BATTERIES (CR SERIES)

GENERAL DESCRIPTION

Panasonic coin type lithium batteries are high energy, high reliability batteries for a variety of applications. The full 3 volts in these high energy batteries is about twice that of conventional dry batteries. Panasonic coin type lithium batteries are available in two types: poly-carbon-monofluoride lithium batteries (BR Series) for users requiring extended reliability and safety, and manganese dioxide lithium batteries (CR Series) for users requiring high voltage and strong load pulse characteristics.

FEATURES

- High voltage of 3 volts — twice that of conventional batteries
- Extremely small self-discharge for long service and shelf life
- Compact and lightweight, with extremely high energy density per unit weight
- Extremely safe (poly-carbon monofluoride lithium batteries)
- Extremely strong load pulse characteristics (manganese dioxide lithium)

APPLICATIONS

- Calculators
- Cameras
- Compact, low power consuming cordless appliances
- Electronic watches (digital and analog)
- Memory backup in all type of devices (with tab terminals)

Operating Temperature BR Type: -30°C ~ 80°C

Operating Temperature CR Type: -30°C ~ 60°C

COIN TYPE



BR COIN CELLS

Model Number	Electrical Characteristics (20°C)				Recommended Drain Continuous (mA)	Dimensions (Max.)		
	JIS	IEC	Nominal Voltage (V)	Nominal Capacity (mAh)		Diameter inch (mm)	Height inch (mm)	Weight oz. (g)
BR1220	-	-	3	35	0.03	0.49 (12.5)	0.08 (2.00)	0.02 (0.7)
BR1225	-	BR1225	3	48	0.03	0.49 (12.5)	0.10 (2.50)	0.03 (0.8)
BR1632	-	-	3	120	0.03	0.63 (16.0)	0.13 (3.20)	0.05 (1.5)
BR2032	-	-	3	190	0.03	0.79 (20.0)	0.13 (3.20)	0.09 (2.5)
BR2325	-	BR2325	3	165	0.03	0.91 (23.0)	0.10 (2.50)	0.11 (3.2)
BR2330	-	-	3	255	0.03	0.91 (23.0)	0.12 (3.00)	0.11 (3.2)
BR3032	-	BR3032	3	500	0.03	1.18 (30.0)	0.13 (3.20)	0.19 (5.5)

*Nominal capacity shown is based on standard drain and cut off voltage down to 2.0V at 20°C (68°F)

BR COIN CELL TAB CONFIGURATIONS

Model Number	Tab Type		Configuration Type	Model Number	Tab Type		Configuration Type
	With Insulation Wrap	Without Insulation Wrap			With Insulation Wrap	Without Insulation Wrap	
BR1220	/HFN		H	BR2325	/HCN	/HBN	H
BR1220	/VCN		V	BR2325	/VCN		V
BR1225	/HCN	/HBN	H	BR2325		/HGN	H
BR1225	/VCN		V	BR2325	/2HCN		H
BR1632	/HFN		H	BR2325		/VGN	V
BR2032		/HGN	G	BR2330	/HFN	/HEN	H
BR2032	/GUFN	/GUN	G	BR2330	/GUFN	/GUN	G
BR2032	/HFN	/HEN	H	BR2330	/VCN	/VBN	V
BR2032		/VBN	V	BR2330	/GVFN	/GVN	V
BR2032	/GVFN	/GVN	V	BR2330	/F3N		F
BR2032	/F2N		F	BR3032	/VCN		V
				BR3032	/F2N		F

Lithium Primary Coin Batteries

CR COIN CELL								
Model Number	Electrical Characteristics (20°C)				Recommended Drain Continuous (mA)	Dimensions (Max.)		
	JIS	IEC	Nominal Voltage (V)	Nominal Capacity (mAh)		Diameter inch (mm)	Height inch (mm)	Weight oz (g)
CR1025	CR1025	CR1025	3	30	0.1	0.39 (10.0)	0.10 (2.5)	0.02 (0.7)
CR1216	CR1216	CR1216	3	25	0.1	0.49 (12.5)	0.06 (1.6)	0.02 (0.7)
CR1220	CR1220	CR1220	3	35	0.1	0.49 (12.5)	0.08 (2.0)	0.04 (1.2)
CR1612	-	-	3	40	0.1	0.63 (16.0)	0.05 (1.2)	0.03 (0.8)
CR1616	CR1616	CR1616	3	55	0.1	0.63 (16.0)	0.06 (1.6)	0.04 (1.2)
CR1620	CR1620	CR1620	3	75	0.1	0.63 (16.0)	0.08 (2.0)	0.05 (1.3)
CR1632	-	-	3	140	0.1	0.63 (16.0)	0.13 (3.2)	0.06 (1.8)
CR2012	CR2012	-	3	55	0.1	0.79 (20.0)	0.05 (1.2)	0.05 (1.4)
CR2016	CR2016	CR2016	3	90	0.1	0.79 (20.0)	0.06 (1.6)	0.06 (1.6)
CR2025	CR2025	CR2025	3	165	0.2	0.79 (20.0)	0.10 (2.5)	0.08 (2.3)
CR2032	CR2032	CR2032	3	225	0.2	0.79 (20.0)	0.13 (3.2)	0.10 (2.9)
CR2330	CR2330	CR2330	3	265	0.2	0.91 (23.0)	0.12 (3.0)	0.13 (3.8)
CR2354	CR2354	CR2354	3	560	0.2	0.91 (23.0)	0.21 (5.4)	0.20 (5.8)
CR2412	-	-	3	100	0.2	0.96 (24.5)	0.05 (1.2)	0.07 (2.0)
CR2450	CR2450	CR2450	3	620	0.2	0.96 (24.5)	0.2 (5.0)	0.20 (6.3)
CR2477	-	-	3	1000	0.2	0.96 (24.5)	0.30 (7.7)	0.37 (10.5)
CR3032	CR3032	CR3032	3	500	0.2	1.18 (30.0)	0.13 (3.2)	0.24 (6.8)

*Nominal capacity shown is based on standard drain and cut off voltage down to 2.0V at 20°C (68°F)

CR COIN CELL TAB CONFIGURATIONS							
Model Number	Tab Type		Configuration Type	Model Number	Tab Type		Configuration Type
	With Insulation Wrap	Without Insulation Wrap			With Insulation Wrap	Without Insulation Wrap	
CR1220	/HFN		H	CR2330	/GUFN	/GUN	G
CR1220	/VCN		V	CR2330	/HFN		H
CR1616		/F2N	F	CR2330	/GVFN	/GVN	V
CR1632	/HFN		H	CR2330	/F3N		F
CR2016	/F2N		F	CR2354	/HFN	/HEN	H
CR2032		/HU3N	H	CR2354	/GUFN	/GUN	G
CR2032		/HGN	G	CR2354	/VCN		V
CR2032	/HSN		H	CR2450	/H1AN		H
CR2032	/GUFN	/GUN	G	CR2450		/G1AN	G
CR2032	/HFN	/HEN	H	CR2477	/VCN		V
CR2032		/VBN	V	CR2477	/HFN		H
CR2032	/GVFN	/GVN	V	CR3032	/VCN		V
CR2032	/F4N		F	CR3032	/F2N		F
CR2032	/F2N		F				

Lithium Primary Coin Batteries

HIGH OPERATING TEMPERATURE POLY-CARBONMONOFLORIDE LITHIUM BATTERIES (BR "A" SERIES)

GENERAL DESCRIPTION

Panasonic's coin type high temperature batteries are high energy, high reliability batteries for applications that require a wider operating temperature range. The full 3 volts in these high energy batteries is about twice that of conventional dry batteries.

FEATURES

- Wide operational temperature range
- Good storage stability
- Constant operating voltage
- Available with Tab terminals for PCB mounting

APPLICATIONS

- Automotive electronic systems
- Tollway transponders
- RFID



HIGH TEMPERATURE BR COIN CELL							
Model Number	Nominal Voltage (V)	Nominal Capacity (mAh)	Recommended Drain Continuous (mA)	Dimensions (max)		Weight oz (g)	Temp. Range °C
				Diameter inch (mm)	Height inch (mm)		
BR1225A	3	48	0.03	0.49 (12.5)	0.10 (2.5)	0.03 (0.8)	-40° C~125° C
BR1632A	3	120	0.03	0.63 (16.0)	0.13 (3.2)	0.05 (1.5)	-40° C~125° C
BR2330A	3	255	0.03	0.91 (23.0)	0.12 (3.0)	0.11 (3.2)	-40° C~125° C
BR2450A	3	550	0.03	0.96 (24.5)	0.20 (5.0)	0.21 (5.0)	-40° C~125° C
BR2477A	3	1000	0.03	0.96 (24.5)	0.30 (7.7)	0.28 (8.0)	-40° C~125° C

Nominal capacity shown is based on standard drain and cut off voltage down to 2.0V at 20°C (68°F)

HIGH TEMPERATURE BR COIN CELL TAB CONFIGURATIONS			
Model Number	Tab Type		Configuration Type
	With Insulation Wrap	Without Insulation Wrap	
BR1225A	/FAN		F
BR1225A	/HBN	/HAN	H
BR1632A	/FAN		F
BR1632A		/GAN	G
BR1632A	/HAN	/HBN	H
BR1632A	/VAN		V
BR2330A	/FAN		F
BR2330A		/GAN	G
BR2330A	/HDN		H
BR2330A	/VAN		V
BR2450A	/FAN		F
BR2450A	/GAN		G
BR2477A	/FBN		F
BR2477A	/GAN		G
BR2477A	/HBN	/HCN	H
BR2477A	/VAN		V

Note: Please refer to the Panasonic website for exact tab dimensions.

Please contact Panasonic for requests on custom tab configurations. Minimum order requirements may apply.

Lithium Primary Cylindrical Batteries

POLY-CARBONMONOFLORIDE LITHIUM BATTERIES (BR SERIES)



GENERAL DESCRIPTION

Panasonic cylindrical lithium batteries are known for their high voltage, energy density, durability, and stable operation.

FEATURES

- High energy density
- Long shelf life
- Stable operation
- High rate discharge
- Strong leakage resistance
- Excellent durability

APPLICATIONS

- Cameras
- Memory back-up
- Utility meters
- Emergency signal light
- Electric locks
- Electronic measurement equipment

BR CYLINDRICAL CELLS

Model Number	Electrical Characteristics			Dimensions		Approximate Weight oz. (g)	Operating Temperature (°C)
	Nominal Voltage (V)	**Nominal Capacity (mAh)	Standard Drain (mA)	Diameter inch (mm)	Height inch (mm)		
BR-C	3	5,000	5.0	1.02 (26.0)	1.99 (50.5)	1.48 (42.0)	- 40 to +85
BR-A	3	1,800	2.5	0.67 (17.0)	1.79 (45.5)	0.63 (18.0)	- 40 to +85
BR-AG*	3	2,200	2.5	0.67 (17.0)	1.79 (45.5)	0.63 (18.0)	- 40 to +85
BR-2/3A	3	1,200	2.5	0.67 (17.0)	1.32 (33.5)	0.48 (13.5)	- 40 to +85
BR-2/3AG*	3	1,450	2.5	0.67 (17.0)	1.32 (33.5)	0.48 (13.5)	- 40 to +85
BR-1/2AA	3	1,000	2.5	0.57 (14.5)	1.00 (25.5)	0.28 (8.0)	- 40 to +100

Note: * G Versions are higher capacity. ** Nominal capacity is based on standard drain and cut off voltage down to 2.0V at 20°C (68°F)

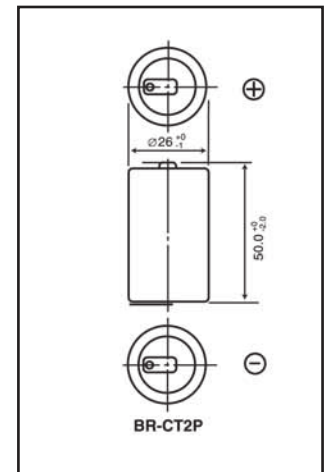
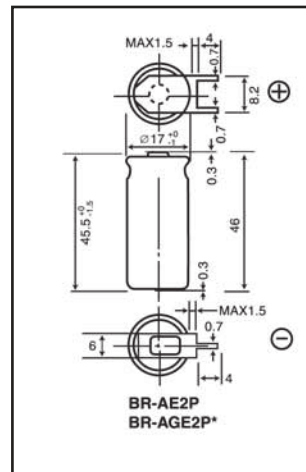
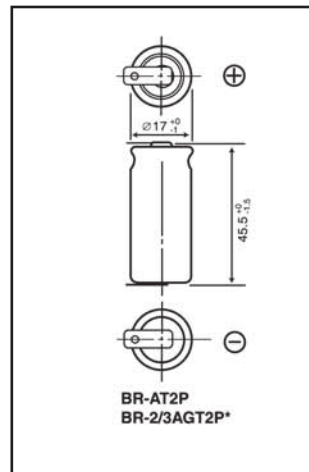
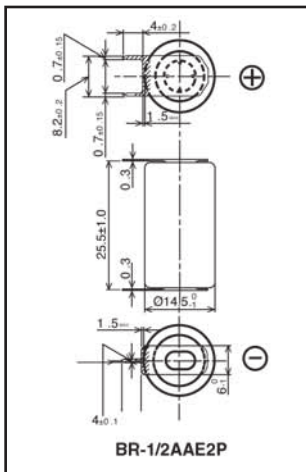
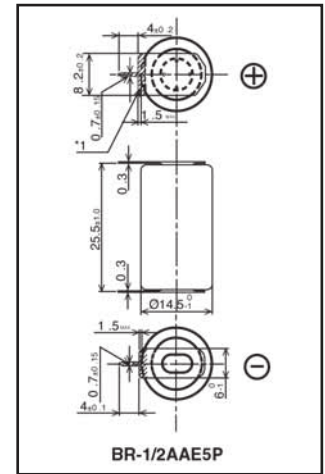
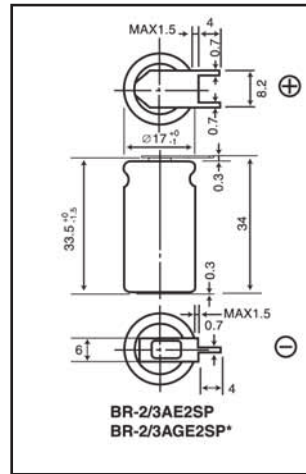
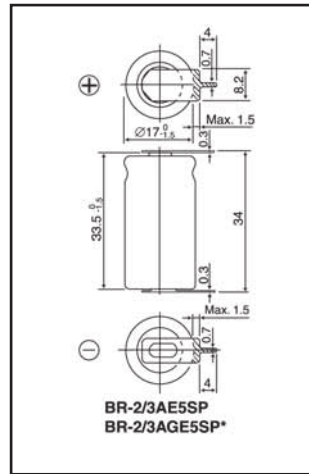
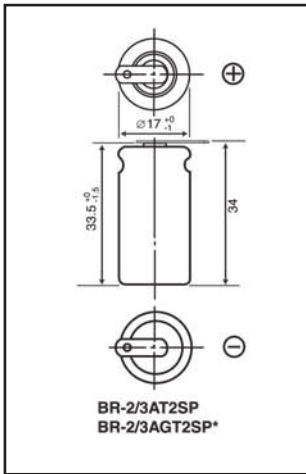

Lithium Primary Cylindrical Batteries

MANGANESE DIOXIDE LITHIUM BATTERIES (CR SERIES) (USER REPLACEABLE)



GENERAL DESCRIPTION

Developed by Panasonic, packaged user replaceable lithium batteries offer high voltage and high energy density. Ideal for designs requiring batteries with retail availability to allow for convenient end user replacement.

FEATURES

- High safety and reliability
- High current pulse discharge capability
- Rapid discharge for strobes is possible at 6V
- Superior shelf life/minimal self-discharge
- Operating temperature (-40°C~70°C)
- High energy density

CR CYLINDRICAL CELLS

Model Number	Voltage (V)	Nominal Capacity (mAh)	Continuous Drain (mA)	Dimensions inch (mm)	Weight oz. (g)
CR123A	3	1,550*	20	0.67 x 1.36 (17.0 x 34.5)	0.60 (17)
CR2	3	850*	20	0.61 x 1.56 (15.6 x 27.0)	0.39 (11)
2CR5	6	1,400**	20	0.67 x 1.34 x 1.79 (17 x 34 x 45)	1.34 (38)
CR-P2	6	1,400**	20	0.77 x 1.38 x 1.42 (19.5 x 35 x 36)	1.31 (37)
CR-V3P	3	3,300*	20	1.03 x 0.51 x 1.84 (29 x 14.5 x 52)	1.38 (39)

* Based on standard drain and cut off voltage down to 2.0 V at 20°C (68°F) ** Based on standard drain and cut off voltage down to 4.0 V at 20°C (68°F)

APPLICATIONS

- Cameras
- Memory back-up over a wide range of applications
- Other applications where ease of replacement is required

Lithium Primary Pin Batteries

MANGANESE DIOXIDE LITHIUM BATTERIES (CR SERIES) FOR INDUSTRIAL APPLICATIONS



CR CYLINDRICAL CELLS

Model Number	Voltage (V)	Nom. Capacity (mAh)	Dimensions inch (mm)	Weight oz. (g)
CR-2/3AZ	3	1,600	0.67 x 1.32 (17.0 x 33.5)	0.60 (17)
CR-AG	3	2400	0.67 x 1.79 (17.0 x 45.5)	0.78

GENERAL DESCRIPTION

The Industrial Appliance CR Series featuring superior high-rate and extended-use performance. Internal resistance remains low during long term discharge such as memory-back-up. "Wake-up-pulse discharge" not required for high current pulse discharge.

FEATURES

- Superior Long Term Reliability
- High current pulse discharge capability
- Operating Temperature (-40 ~70)
- High safety and energy density

APPLICATIONS

- Meter, AMR (Automatic Meter Reading)
- Fire Alarm (Smoke Detector)
- Home Security Device
- ETC (Electric toll collection)

POLY-CARBONMONOFLUORIDE LITHIUM BATTERIES (BR SERIES)

GENERAL DESCRIPTION

Panasonic carbon monofluoride pin type lithium batteries are slim and lightweight through the use of an aluminum case. This unique design, developed first by Panasonic, combines the best of battery technologies.

FEATURES

- Compact and lightweight
- 2x the voltage of conventional dry batteries
- Operating temperature (-30°C~+60°C)
- Pin terminal for easy connection

APPLICATIONS

- Fishing pole tip lights
- LED illumination
- LED night fishing floats
- Microphones

BR PIN CELLS



Model Number	Electrical Characteristics				Dimensions		Weight oz (g)
	Nominal Voltage	Nominal Capacity (mAh)	Recommended Drain		Diameter Inch (mm)	Height Inch (mm)	
			Pulse (mA)	Standard (mA)			
BR425	3	25	4	0.5	0.17 (4.2)	1.02 (25.9)	0.02 (0.6)
BR435	3	50	6	1.0	0.17 (4.2)	1.41 (35.9)	0.03 (0.9)

Nominal capacity is based on standard drain and cut off voltage down to 2.0V at 20°C (68°F)

Valve Regulated Lead Acid Batteries



FEATURES

- High quality and reliability
- Exceptional deep discharge recovery
- No corrosive gas generation
- Long service life
- Quick chargeability
- High power density
- Maintenance-free operation

APPLICATIONS

- UPS (uninterruptible power supplies)
- Emergency lighting
- Wheelchairs
- Telecom back-up power supplies
- Lawn and garden tools
- Engine starters
- Energy storage

GENERAL DESCRIPTION

Panasonic's tough valve regulated lead acid (VRLA) rechargeable batteries are designed to provide outstanding performance in withstanding overcharge, overdischarge, and resisting vibration and shock. These compact batteries save installation space while providing full and reliable power. The use of special sealing epoxies, tongue and groove case construction, long-sealing paths for posts and connectors assures that the battery will offer exceptional leak resistance.

Panasonic VRLA batteries utilize pasted lead-calcium plates with the electrolyte in the battery held captive in an Absorbent Glass Mat (AGM) separator located between the plates that immobilizes the electrolyte in the cell. AGM separator material is a highly porous, absorbent micro fiberglass mat mixed with polymer fibers that immobilizes the electrolyte and creates a situation where a spill of electrolyte is highly unlikely.

Panasonic Valve Regulated Lead Acid batteries (weighing less than 2 lbs) are covered by the Rechargeable Battery Recycling Corporation's (RBRC) recycling program. For larger batteries call 1-800-SAV-LEAD.



BACK-UP AND MAIN POWER SUPPLIES (CYCLE AND TRICKLE USE)

Model Number*	Nominal Voltage (V)	Rated capacity 20 hours rate (Ah)	Outline dimensions inch (mm)				Wt. (Approx.) lbs (kg)	Terminal Types	Battery-case resin	
			Length	Width	Height	Total height			UL94HB	UL94V-0
LC-R061R3P	6	1.3	3.82 (97)	0.95 (24)	1.97 (50)	2.17 (55)	0.66 (0.30)	B	○	
LC-R063R4P	6	3.4	5.28 (134)	1.34 (34)	2.36 (60)	2.6 (66)	1.37 (0.62)	B	○	
LC-R064R5P	6	4.5	2.76 (70)	1.89 (48)	4.02 (102)	4.26 (108)	1.72 (0.78)	B	○	
LC-R067R2P(a)	6	7.2	5.95 (151)	1.34 (34)	3.70 (94)	3.94 (100)	2.78 (1.26)	B/C	○	
LC-R0612P(a)	6	12.0	5.95 (151)	1.97 (50)	3.70 (94)	3.94 (100)	4.30 (1.95)	B/C	○	
LC-R121R3P	12	1.3	3.82 (97)	1.87 (48)	1.97 (50)	2.17 (55)	1.30 (0.59)	B	○	
LC-R122R2P	12	2.2	6.97 (177)	1.34 (34)	2.36 (60)	2.6 (66)	1.76 (0.80)	B	○	
LC-R123R4P	12	3.4	5.28 (134)	2.64 (67)	2.36 (60)	2.6 (66)	2.65 (1.20)	B	○	
LC-R127R2P(a)	12	7.2	5.95 (151)	2.54 (64.5)	3.70 (94)	3.94 (100)	5.45 (2.47)	B/C	○	
LC-RA1212P(a)	12	12.0	5.95 (151)	3.86 (98)	3.70 (94)	3.94 (100)	8.36 (3.80)	B/C	○	
LC-RD1217P	12	17.0	7.13 (181)	2.99 (76)	6.58 (167)	6.58 (167)	14.34 (6.50)	D	○	
LC-R1233P	12	33.0	7.70 (195.6)	5.12 (130)	6.10 (155)	7.09 (180)	26.50 (12.0)	E	○	●

* Previous model number is given in parentheses

(a) Add applicable codes for terminal type: P = faston 187, P1 = faston 250

Note: Battery cases marked with a (○) are the normal product using the standard resin.

Those marked with a solid circle (●) indicate specifications as per special order.

Valve Regulated Lead Acid Batteries

MAIN POWER SUPPLIES (CYCLE USE)

Model Number	Nominal Voltage (V)	Rated capacity 20 hours rate (Ah)	Outline dimensions inch (mm)				Wt. (Approx.) lbs (kg)	Terminal Types	Battery-case resin	
			Length	Width	Height	Total height			UL94HB	UL94V-0
LC-XC1228AP	12	28.0	6.50 (165)	4.92 (125)	6.89 (175)	7.07 (179.5)	24.34 (11)	G	○	

Note: Battery cases marked with an ○ are the normal product using the standard resin. Those marked with a solid circle ● indicate specifications as per special order.

BACK-UP POWER SUPPLIES (LONG LIFE TRICKLE USE*)

Model Number	Nominal Voltage (V)	Rated capacity 20 hours rate (Ah)	Outline dimensions inch (mm)				Wt. (Approx.) lbs (kg)	Terminal Types	Battery-case resin	
			Length	Width	Height	Total height			UL94HB	UL94V-0
LC-P067R2P(a)	6	7.2	5.95 (151)	1.34 (34)	3.70 (94)	3.94 (100)	2.87 (1.3)	B/C		
LC-P0612P(a)	6	12.0	5.95 (151)	1.97 (50)	3.70 (94)	3.94 (100)	4.41 (2.0)	B/C		
LC-P127R2P(a)	12	7.2	5.95 (151)	2.54 (64.5)	3.70 (94)	3.94 (100)	5.52 (2.5)	B/C		○
LC-PD1217P	12	17.0	7.13 (181)	2.99 (76)	6.58 (167)	6.58 (167)	14.34 (6.5)	D	●	
LC-P1220P	12	20.0	7.13 (181)	2.99 (76)	6.58 (167)	6.58 (167)	14.6 (6.6)	D	○	
LC-P1220AP	12	20.0	7.13 (181)	2.99 (76)	6.58 (167)	6.58 (167)	14.6 (6.6)	G	●	
LC-P1228P	12	28.0	6.50 (165)	4.92 (125)	6.89 (175)	7.07 (179.5)	24.3 (11)	D	○	
LC-P1228AP	12	28.0	6.50 (165)	4.92 (125)	6.89 (175)	6.89 (175)	24.3 (11)	G	○	●

(a) Add applicable codes for terminal type: P = faston 187, P1 = faston 250, P2 = 187/250
 Note: Battery cases marked with an ○ are the normal product using the standard resin. Those marked with a solid circle ● indicate specifications as per special order.

*Expected trickle life approximately 6 years

BACK-UP POWER (HIGH POWER SERIES)

Model Number	Nominal Voltage (V)	Rated capacity Watts/Cell at 10 Minute Rate	Outline dimensions inch (mm)				Wt. (Approx.) lbs (kg)	Terminal Types	Battery-case resin	
			Length	Width	Height	Total height			UL94HB	UL94V-0
UP-VW1220P1	12	20	5.51 (140)	1.52 (38.5)	3.70 (94)	4.00 (101.5)	2.98 (1.35)	C	○	●
UP-VW1245P1	12	45	5.95 (151)	2.54 (64.5)	3.70 (94)	4.00 (101.5)	5.74 (2.6)	C	○	
UP-VW1228P1	12	28	5.95 (151)	2.54 (64.5)	3.70 (94)	4.00 (101.5)	4.07 (1.85)	C		
UP-VW1236P1	12	36	5.95 (151)	2.54 (64.5)	3.70 (94)	4.00 (101.5)	4.51 (2.05)	C		

TERMINAL TYPES:

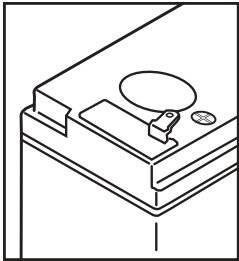

(B) Faston type 187
 (C) Faston type 250
 Indicated by model # suffix:
 P=187
 P1=250
 P2=250(+)/187(-)

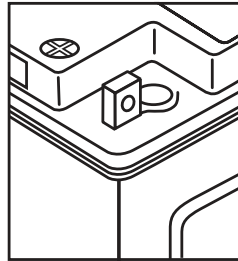

(D) M5 bolt and nut type
 (E) M6 bolt and nut type
 Indicated by model # suffix: P

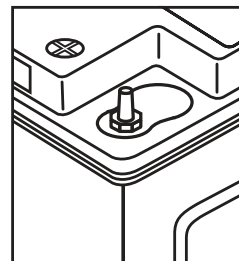

(G) M5 threaded post type
 (H) M6 threaded post type
 Indicated by model # suffix: AP

WIND TURBINE PITCH CONTROL

Model Number	Nominal Voltage (V)	Rated capacity Watts/Cell at 10 Minute Rate	Outline dimensions inch (mm)				Wt. (Approx.) lbs	Terminal Types	Battery-case resin	
			Length	Width	Height	Total height			UL94HB	UL94V-0
LC-WTV127R2	12	7.2	5.95	2.53	3.71	3.94	5.51	NA		●
LC-WTV1212	12	12	5.95	3.86	3.71	3.94	8.49	NA		●
LC-WTP127R2	12	7.2	5.95	2.53	3.71	3.94	5.51	NA		●
LC-WTP1212	12	12	5.95	3.86	3.71	3.94	8.49	NA		●

Alkaline Batteries

GENERAL DESCRIPTION

Panasonic Industrial brand Alkalines are designed with a power reservoir that enables them to last longer. High current and large capacity are standard, which means high performance for our customers. Panasonic Industrial Alkaline batteries are made in the USA at our state-of-the-art manufacturing facility in Columbus, Georgia.

FEATURES

- Heavy current and continuous drain
- Operates reliably in temperature range of -20°C to 54°C (40°F to 130°F)
- Individual date coded to guarantee freshness prior to use
- Up to 7 year shelf life when stored at 25°C/77°F 80% capacity (except 9V which are 5 year shelf life)
- EU compliant dustbin symbol
- Easier cross-referencing with IEC battery codes



APPLICATIONS

- Portable stereos
- Radio-cassette recorders
- Strobes
- Cameras
- Electronic calculators
- Electric shavers
- High-powered flashlights
- Electric doorlocks
- Emergency lighting
- Toys and other cordless products
- Transportation
- Security
- Contractors
- HVAC

INDUSTRIAL ALKALINE BATTERIES

Model Number	Size	V	Diameter Inch (mm)	Height Inch (mm)	Avg. Wt. oz (g)
LR20XWA	D	1.5	1.312 (33.3)	2.407 (60.5)	4.97 (141.0)
LR14XWA	C	1.5	1.004 (25.5)	1.969 (49.5)	2.47 (70.0)
LR6XWA	AA	1.5	.571 (14.50)	1.988 (50.0)	0.80 (23.0)
LR03XWA	AAA	1.5	.413 (10.20)	1.752 (44.10)	0.38 (11.0)

Model Number	V	L Inch (mm)	W Inch (mm)	D Inch (mm)	Avg. Wt. oz (g)
6LR61XWA (9V)	9	1.0 (47.5)	1.0 (25.50)	0.649 (17.50)	1.60 (45)

Panasonic Industrial

Many products sold by Fortune 500 companies are in fact **Powered by Panasonic** technology, and we are proud to provide manufacturers with the **performance, quality, and reliability** that are synonymous with the Panasonic brand.

The Power of Panasonic Industrial brings strategic **innovations** to our customers' product development process. We provide the **technology and engineering resources** to enable manufacturers to plan and build **world-class solutions** to meet their **customer needs**.

Engineering and manufacturing power form the core of our company's **strength**, infusing our entire product line, from the smallest chip to giant HD displays. Prior to becoming a global consumer electronics powerhouse, Panasonic began its existence by developing **component and material technologies** that still serve as the **building blocks** for the wide range of advanced products for which our company is best known today, and this development continues.

Our technology is **deeply embedded** within our customers' products, so consumers may not realize that their refrigerator has at its heart a Panasonic compressor, their mobile device relies upon our components and batteries, their computer contains our DVD drive, or their television uses our display panels. Our measure of success is the **confidence and trust** shown in our technology when it becomes the power behind our customers' products.

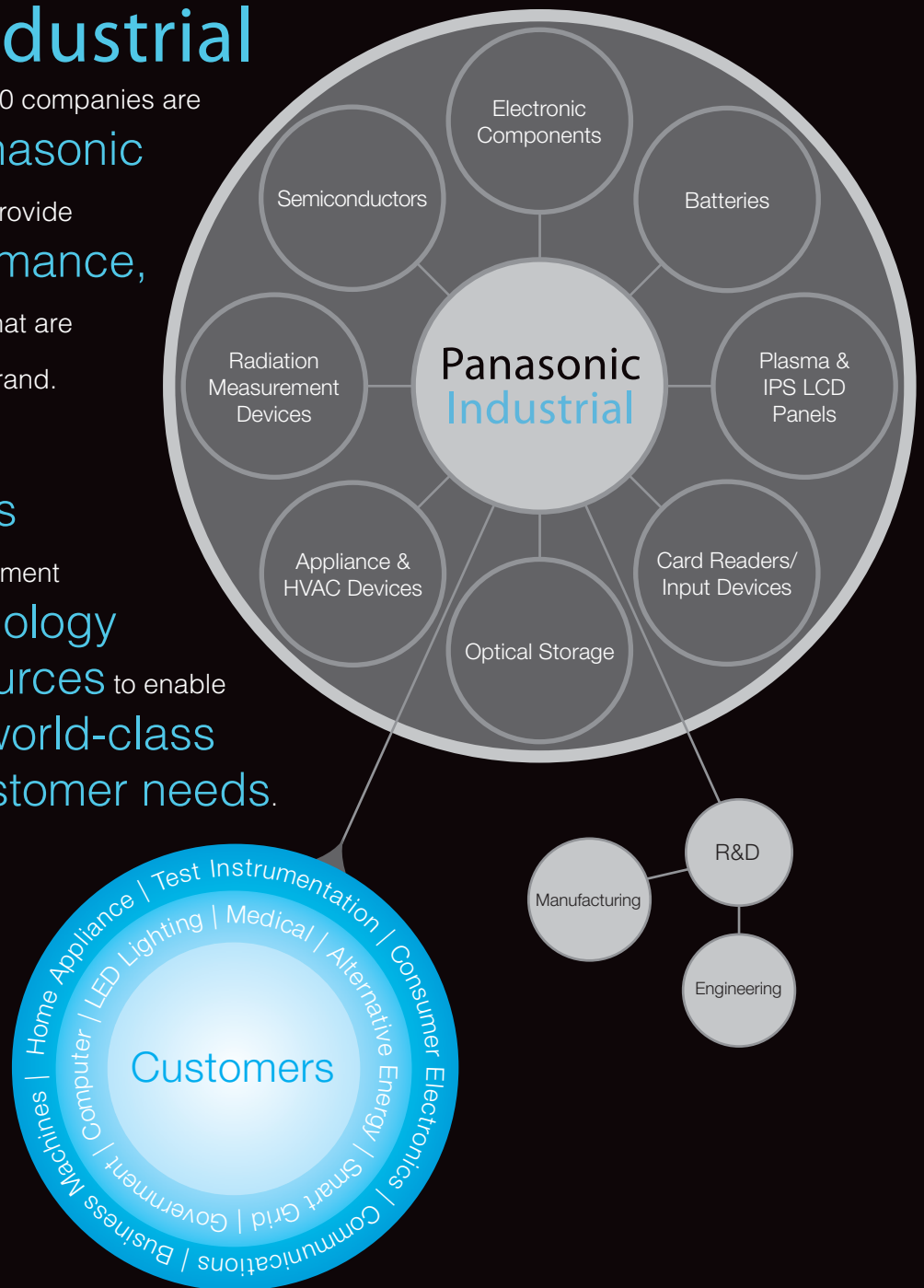



For more information on how Panasonic can assist you
with your battery power solution needs call **877-726-2228**,
visit **www.panasonic.com/industrial/batteries-oem**
or e-mail **oembatteries@us.panasonic.com**

Panasonic ideas for life

Panasonic Batteries 5201 Tollview Drive Rolling Meadows Illinois 60008

Copyright © 2011 Panasonic Corporation of North America. All Rights Reserved. PIC-PanBat-FY11-PanaEnergyCatalog