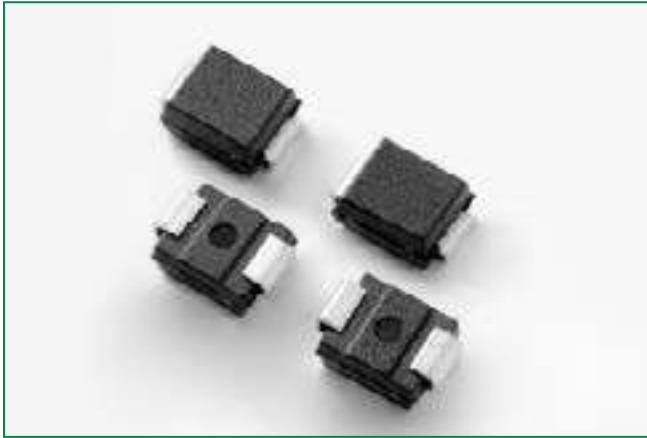


## SZ1SMB Series



### Description

The SZ1SMB series is designed to protect voltage sensitive components from high voltage, high energy transients. They have excellent clamping capability, high surge capability, and fast response time. The SZ1SMB series is supplied in the Littelfuse exclusive, cost-effective, highly reliable package and is ideally suited for use in communication systems, automotive, numerical controls, process controls, medical equipment, business machines, power supplies and many other industrial/consumer applications.

### Features

- Working Peak Reverse Voltage Range – 5.0 V to 170 V for unidirectional, and 10 V to 75 V for bidirectional
- Standard Avalanche Breakdown Voltage Range – 6.7 V to 199 V for uni-directional, 11.7 V to 91.7 V for bi-directional
- Peak Power – 600 W @ 1.0 ms
- ESD Rating of Class 3 (> 16 kV) per Human Body Model
- Maximum Clamp Voltage @ Peak Pulse Current
- Low Leakage < 5.0  $\mu$ A Above 10 V
- Intended for UL 497B Type Protection
- Response Time is Typically < 1.0 ns
- Pb-free means 2nd level interconnect is Pb-free and the terminal finish material is tin(Sn) (IPC/JEDEC J-STD-609A.01)
- SZ Prefix for Automotive and Other Applications Requiring Unique Site and Control Change Requirements; AEC-Q101 Qualified and PPAP Capable

### Maximum Ratings and Thermal Characteristics

Parameter	Symbol	Value	Unit
Peak Power Dissipation (Note 1) @ $T_L = 25^\circ\text{C}$ , Pulse Width = 1 ms	$P_{PK}$	600	W
DC Power Dissipation @ $T_L = 75^\circ\text{C}$ Measured Zero Lead Length (Note 2) Derate Above $75^\circ\text{C}$	$P_D$	3.0	W
Thermal Resistance from Junction-to-Lead	$R_{\theta JL}$	40	$\text{mW}/^\circ\text{C}$
DC Power Dissipation (Note 3) @ $T_A = 25^\circ\text{C}$ Derate Above $25^\circ\text{C}$	$P_D$	0.55	W
Thermal Resistance from Junction-to-Ambient	$R_{\theta JL}$	4.4	$\text{mW}/^\circ\text{C}$
	$R_{\theta JA}$	226	$^\circ\text{C}/\text{W}$
Forward Surge Current (Note 4) @ $T_A = 25^\circ\text{C}$	$I_{FSM}$	100	A
Operating and Storage Temperature Range	$T_J, T_{stg}$	-65 to +150	$^\circ\text{C}$

Stresses exceeding those listed in the Maximum Ratings table may damage the component. If any of these limits are exceeded, device functionality should not be assumed, damage may occur and reliability may be affected.

1. 10/1000  $\mu$ s, non-repetitive.
2. 1" square copper pad, FR-4 board.
3. FR-4 board, using Littelfuse minimum recommended footprint, as shown in 403A-03 case outline dimensions spec.
4. 1/2 sine wave (or equivalent square wave), PW = 8.3 ms, duty cycle = 4 pulses per minute maximum - For Unidirectional only.

### Additional Information



Datasheet

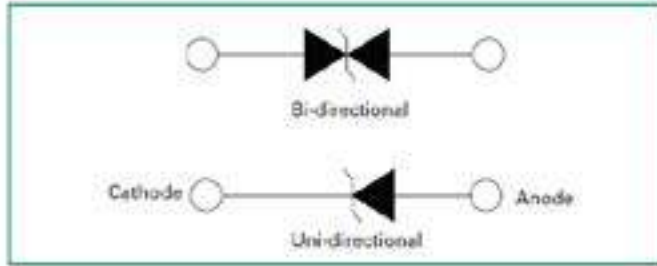


Resources

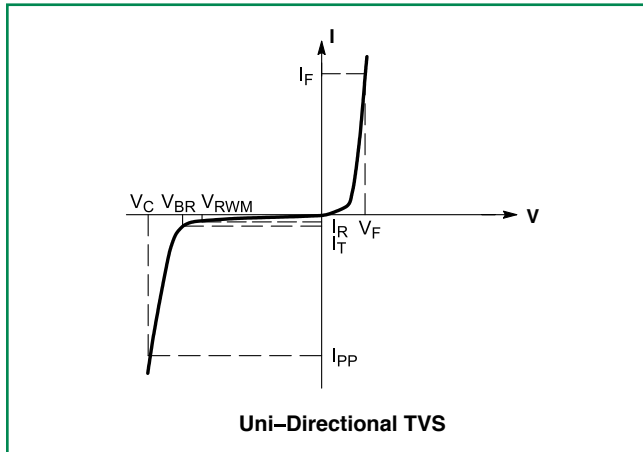


Samples

**Functional Diagram**



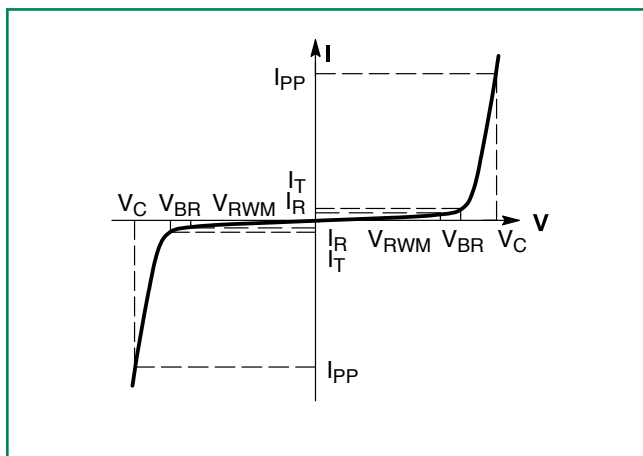
**I-V Curve Characteristics** ( $T_A = 25^\circ\text{C}$  unless otherwise noted,  $V_F = 3.5\text{ V Max.}$  @  $I_F$  (Note 5) = 30 A) (For Unidirectional)



Symbol	Parameter
$I_{PP}$	Maximum Reverse Peak Pulse Current
$V_C$	Clamping Voltage @ $I_{PP}$
$V_{RWM}$	Working Peak Reverse Voltage
$I_R$	Maximum Reverse Leakage Current @ $V_{RWM}$
$V_{BR}$	Breakdown Voltage @ $I_T$
$I_T$	On-State Current
$I_F$	Maximum Temperature Coefficient of $V_{BR}$
$V_F$	Forward Voltage @ $I_F$

5. 1/2 sine wave (or equivalent square wave),  $PW = 8.3\text{ ms}$ , non-repetitive duty cycle.

**I-V Curve Characteristics** ( $T_A = 25^\circ\text{C}$  unless otherwise noted) – For Bidirectional



Symbol	Parameter
$I_{PP}$	Maximum Reverse Peak Pulse Current
$V_C$	Clamping Voltage @ $I_{PP}$
$V_{RWM}$	Working Peak Reverse Voltage
$I_R$	Maximum Reverse Leakage Current @ $V_{RWM}$
$V_{BR}$	Breakdown Voltage @ $I_T$
$I_T$	On-State Current
$I_F$	Maximum Temperature Coefficient of $V_{BR}$
$V_F$	Forward Voltage @ $I_F$
$V_F$	Forward Voltage @ $I_F$

## Electrical Characteristics - For Unidirectional

Device*	Device Marking	$V_{RWM}$ (Note 6)	$I_R @ V_{RWM}$	Breakdown Voltage				$V_C @ I_{PP}$ (Note 8)		C Typ. (Note 9)
				$V_{BR} @ I_T$ (V) (Note 7)			@ $I_T$	$V_C$	$I_{PP}$	
				Volts	$\mu A$	MIN	NOM	MAX	mA	Volts
SZ1SMB5.0AT3G	KE	5.0	800	6.40	6.7	7.0	10	9.2	65.2	2700
SZ1SMB6.0AT3G	KG	6.0	800	6.67	7.02	7.37	10	10.3	58.3	2300
SZ1SMB6.5AT3G	KK	6.5	500	7.22	7.6	7.98	10	11.2	53.6	2140
SZ1SMB7.0AT3G	KM	7.0	500	7.78	8.19	8.6	10	12.0	50.0	2005
SZ1SMB7.5AT3G	KP	7.5	100	8.33	8.77	9.21	1.0	12.9	46.5	1890
SZ1SMB8.0AT3G	KR	8.0	50	8.89	9.36	9.83	1.0	13.6	44.1	1780
SZ1SMB8.5AT3G	KT	8.5	10	9.44	9.92	10.4	1.0	14.4	41.7	1690
SZ1SMB9.0AT3G	KV	9.0	5.0	10.0	10.55	11.1	1.0	15.4	39.0	1605
SZ1SMB10AT3G	KX	10	5.0	11.1	11.7	12.3	1.0	17.0	35.3	1460
SZ1SMB11AT3G	KZ	11	5.0	12.2	12.85	13.5	1.0	18.2	33.0	1345
SZ1SMB12AT3G	LE	12	5.0	13.3	14	14.7	1.0	19.9	30.2	1245
SZ1SMB13AT3G	LG	13	5.0	14.4	15.15	15.9	1.0	21.5	27.9	1160
SZ1SMB14AT3G	LK	14	5.0	15.6	16.4	17.2	1.0	23.2	25.8	1085
SZ1SMB15AT3G	LM	15	5.0	16.7	17.6	18.5	1.0	24.4	24.0	1020
SZ1SMB16AT3G	LP	16	5.0	17.8	18.75	19.7	1.0	26.0	23.1	965
SZ1SMB17AT3G	LR	17	5.0	18.9	19.9	20.9	1.0	27.6	21.7	915
SZ1SMB18AT3G	LT	18	5.0	20.0	21.05	22.1	1.0	29.2	20.5	870
SZ1SMB20AT3G	LV	20	5.0	22.2	23.35	24.5	1.0	32.4	18.5	790
SZ1SMB22AT3G	LX	22	5.0	24.4	25.65	26.9	1.0	35.5	16.9	730
SZ1SMB24AT3G	LZ	24	5.0	26.7	28.1	29.5	1.0	38.9	15.4	675
SZ1SMB26AT3G	ME	26	5.0	28.9	30.4	31.9	1.0	42.1	14.2	630
SZ1SMB28AT3G	MG	28	5.0	31.1	32.75	34.4	1.0	45.4	13.2	590
SZ1SMB30AT3G	MK	30	5.0	33.3	35.05	36.8	1.0	48.4	12.4	555
SZ1SMB33AT3G	MM	33	5.0	36.7	38.65	40.6	1.0	53.3	11.3	510
SZ1SMB36AT3G	MP	36	5.0	40.0	42.1	44.2	1.0	58.1	10.3	470
SZ1SMB40AT3G	MR	40	5.0	44.4	46.75	49.1	1.0	64.5	9.3	430
SZ1SMB43AT3G	MT	43	5.0	47.8	50.3	52.8	1.0	69.4	8.6	400
SZ1SMB45AT3G	MV	45	5.0	50.0	52.65	55.3	1.0	72.7	8.3	385
SZ1SMB48AT3G	MX	48	5.0	53.3	56.1	58.9	1.0	77.4	7.7	365
SZ1SMB51AT3G	MZ	51	5.0	56.7	59.7	62.7	1.0	82.4	7.3	345
SZ1SMB54AT3G	NE	54	5.0	60.0	63.15	66.3	1.0	87.1	6.9	330
SZ1SMB58AT3G	NG	58	5.0	64.4	67.8	71.2	1.0	93.6	6.4	310
SZ1SMB60AT3G	NK	60	5.0	66.7	70.2	73.7	1.0	96.8	6.2	300
SZ1SMB64AT3G	NM	64	5.0	71.1	74.85	78.6	1.0	103	5.8	280
SZ1SMB70AT3G	NP	70	5.0	77.8	81.9	86	1.0	113	5.3	260
SZ1SMB75AT3G	NR	75	5.0	83.3	87.7	92.1	1.0	121	4.9	245

### Electrical Characteristics - For Unidirectional - Continued

Device*	Device Marking	V <sub>RWM</sub> (Note 6)	I <sub>R</sub> @ V <sub>RWM</sub>	Breakdown Voltage				V <sub>C</sub> @ I <sub>PP</sub> (Note 8)		C Typ. (Note 9)
				V <sub>BR</sub> @ I <sub>T</sub> (V) (Note 7)			@ I <sub>T</sub>	V <sub>C</sub>	I <sub>PP</sub>	
				Volts	μA	MIN	NOM	MAX	mA	Volts
SZ1SMB85AT3G	NV	85	55.0	94.4	99.2	104	1.0	137	4.4	220
SZ1SMB90AT3G	NX	90	5.0	100	105.5	111	1.0	146	4.1	210
SZ1SMB100AT3G	NZ	100	5.0	111	117	123	1.0	162	3.7	190
SZ1SMB110AT3G	PE	110	5.0	122	128.5	135	1.0	177	3.4	175
SZ1SMB120AT3G	PG	120	5.0	133	140	147	1.0	193	3.1	160
SZ1SMB130AT3G	PK	130	5.0	144	151.5	159	1.0	209	2.9	150
SZ1SMB150AT3G	PM	150	5.0	167	176	185	1.0	243	2.5	135
SZ1SMB160AT3G	PP	160	5.0	178	187.5	197	1.0	259	2.3	125
SZ1SMB170AT3G	PR	170	5.0	189	199	209	1.0	275	2.2	120

6. A transient suppressor is normally selected according to the working peak reverse voltage (V<sub>RWM</sub>), which should be equal to or greater than the DC or continuous peak operating voltage level.

7. V<sub>BR</sub> measured at pulse test current I<sub>T</sub> at an ambient temperature of 25°C.

8. Surge current waveform per Figure 1 and derate per Figure 3 of the General Data – 600 W at the beginning of this group.

9. Bias Voltage = 0 V, F = 1 MHz, T<sub>J</sub> = 25°C

### Electrical Characteristics - For Bidirectional

Device *	Device Marking	V <sub>RWM</sub> (Note 6)	I <sub>R</sub> @ V <sub>RWM</sub>	Breakdown Voltage				V <sub>C</sub> @ I <sub>PP</sub> (Note 8)		C Typ. (Note 9)
				V <sub>BR</sub> @ I <sub>T</sub> (V) (Note 7)			@ I <sub>T</sub>	V <sub>C</sub>	I <sub>PP</sub>	
				Volts	μA	MIN	NOM	MAX	mA	Volts
SZ1SMB10CAT3G	KXC	10	5.0	11.1	11.69	12.27	1.0	17.0	35.3	805
SZ1SMB11CAT3G	KZC	11	5.0	12.2	12.84	13.5	1.0	18.2	33.0	740
SZ1SMB12CAT3G	LEC	12	5.0	13.3	14.00	14.7	1.0	19.9	30.2	680
SZ1SMB13CAT3G	LGC	13	5.0	14.4	15.16	15.9	1.0	21.5	27.9	630
SZ1SMB14CAT3G	LKC	14	5.0	15.6	16.42	17.2	1.0	23.2	25.8	590
SZ1SMB15CAT3G	LMC	15	5.0	16.7	17.58	18.5	1.0	24.4	24.0	555
SZ1SMB16CAT3G	LPC	16	5.0	17.8	18.74	19.7	1.0	26.0	23.1	520
SZ1SMB17CAT3G	LRC	17	5.0	18.9	19.90	20.9	1.0	27.6	21.7	490
SZ1SMB18CAT3G	LTC	18	5.0	20.0	21.06	22.1	1.0	29.2	20.5	465
SZ1SMB20CAT3G	LVC	20	5.0	22.2	23.37	24.5	1.0	32.4	18.5	425
SZ1SMB22CAT3G	LXC	22	5.0	24.4	25.69	27.0	1.0	35.5	16.9	390
SZ1SMB24CAT3G	LZC	24	5.0	26.7	28.11	29.5	1.0	38.9	15.4	366
SZ1SMB26CAT3G	MEC	26	5.0	28.9	30.42	31.9	1.0	42.1	14.2	330
SZ1SMB28CAT3G	MGC	28	5.0	31.1	32.74	34.4	1.0	45.4	13.2	310
SZ1SMB30CAT3G	MKC	30	5.0	33.3	35.06	36.8	1.0	48.4	12.4	290
SZ1SMB33CAT3G	MMC	33	5.0	36.7	38.63	40.6	1.0	53.3	11.3	265
SZ1SMB36CAT3G	MPC	36	5.0	40.0	42.11	44.2	1.0	58.1	10.3	245
SZ1SMB40CAT3G	MRC	40	5.0	44.4	46.74	49.1	1.0	64.5	9.3	220
SZ1SMB43CAT3G	MTC	43	5.0	47.8	50.32	52.8	1.0	69.4	8.6	210
SZ1SMB45CAT3G	MVC	45	5.0	50.0	52.63	55.3	1.0	72.2	8.3	200
SZ1SMB48CAT3G	MXC	48	5.0	53.3	56.11	58.9	1.0	77.4	7.7	190
SZ1SMB51CAT3G	MZC	51	5.0	56.7	59.69	62.7	1.0	82.4	7.3	175
SZ1SMB54CAT3G	NEC	54	5.0	60.0	63.16	66.32	1.0	87.1	6.9	170
SZ1SMB58CAT3G	NGC	58	5.0	64.4	67.79	71.18	1.0	93.6	6.4	155
SZ1SMB60CAT3G	NKC	60	5.0	66.7	70.21	73.72	1.0	96.8	6.2	150
SZ1SMB64CAT3G	NMC	64	5.0	71.1	74.84	78.58	1.0	103	5.8	145
SZ1SMB75CAT3G	NRC	75	5.0	83.3	91.65	92.07	1.0	121	4.9	125

6. A transient suppressor is normally selected according to the working peak reverse voltage (V<sub>RWM</sub>), which should be equal to or greater than the DC or continuous peak operating voltage level.

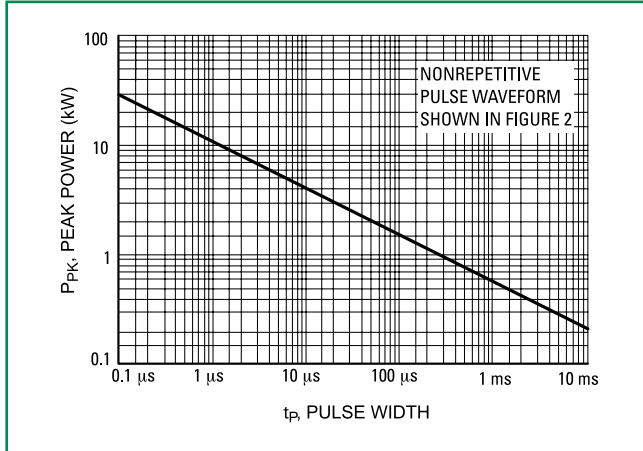
7. V<sub>BR</sub> measured at pulse test current I<sub>T</sub> at an ambient temperature of 25°C.

8. Surge current waveform per Figure 1 and derate per Figure 3 of the General Data – 600 Watt at the beginning of this group.

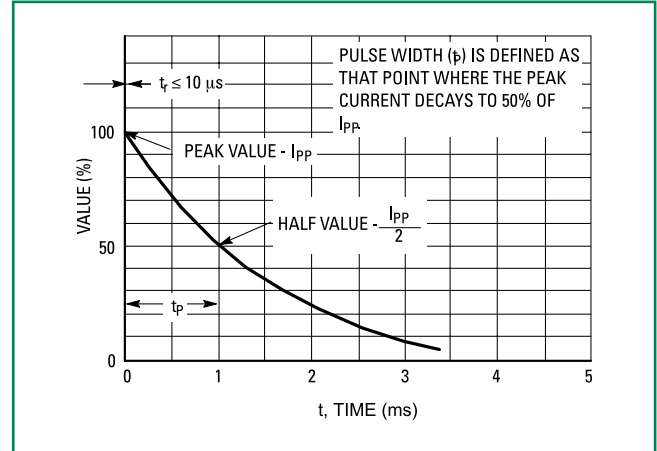
9. Bias Voltage = 0 V, F = 1 MHz, T<sub>J</sub> = 25°C

**Ratings and Characteristic Curves - For Unidirectional**

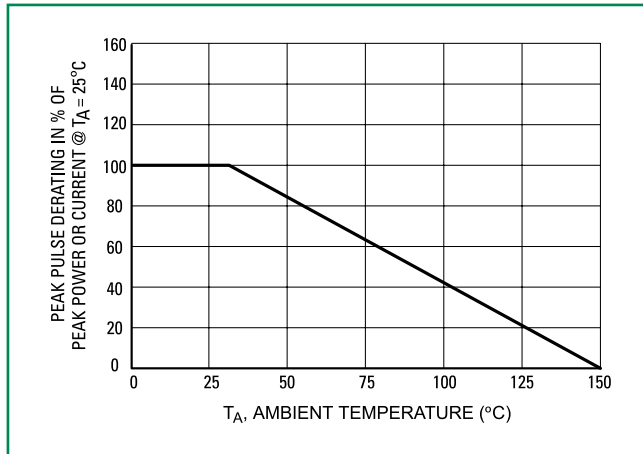
**Figure 1. Pulse Rating Curve**



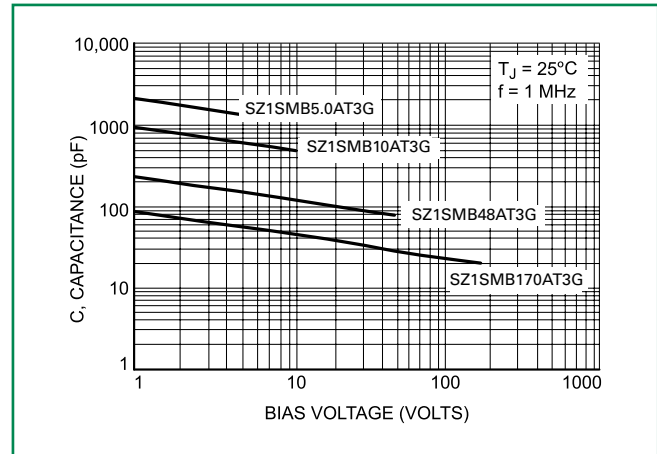
**Figure 2. Pulse Waveform**



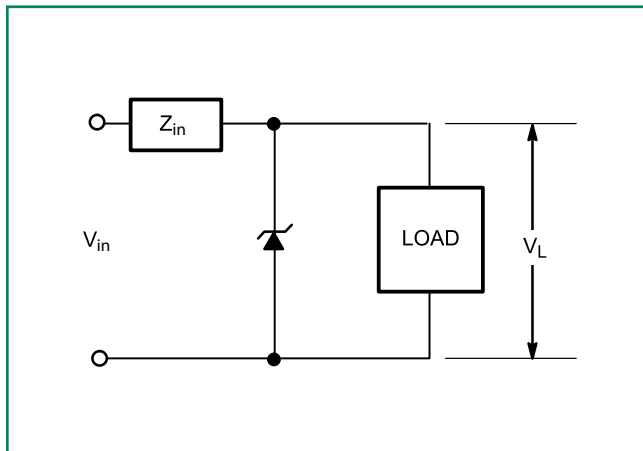
**Figure 3 - Pulse Derating Curve**



**Figure 4. Typical Junction Capacitance vs. Bias Voltage**

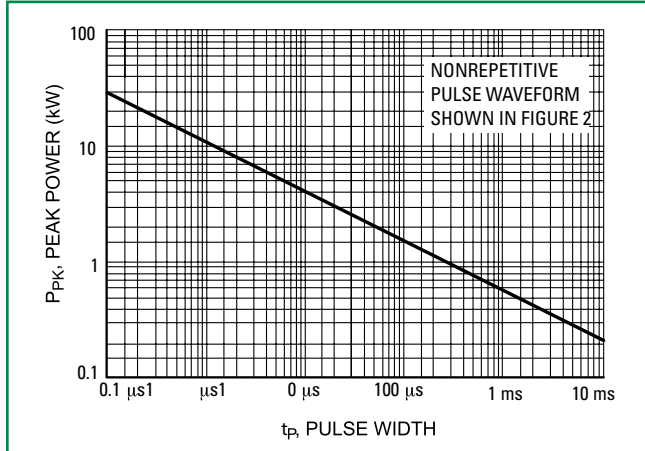


**Figure 5. Typical Protection Circuit**

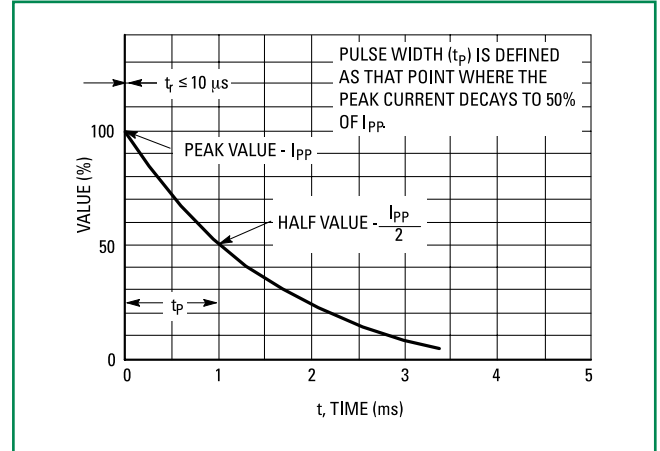


**Ratings and Characteristic Curves - For Bidirectional**

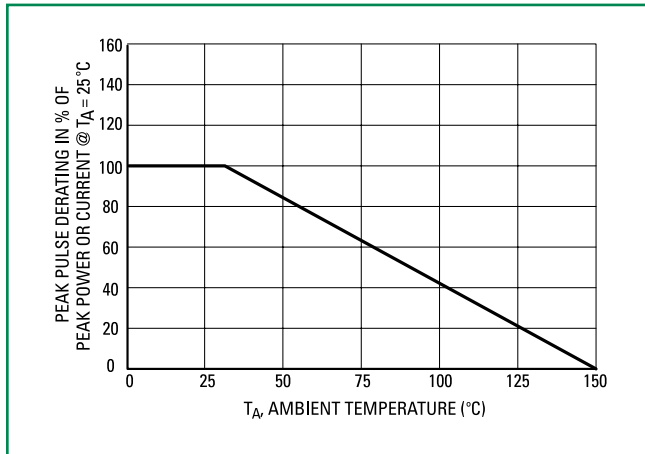
**Figure 6. Pulse Rating Curve**



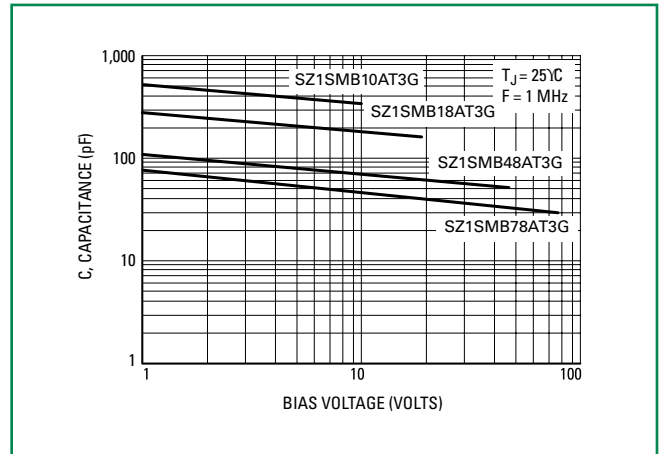
**Figure 7. Pulse Waveform**



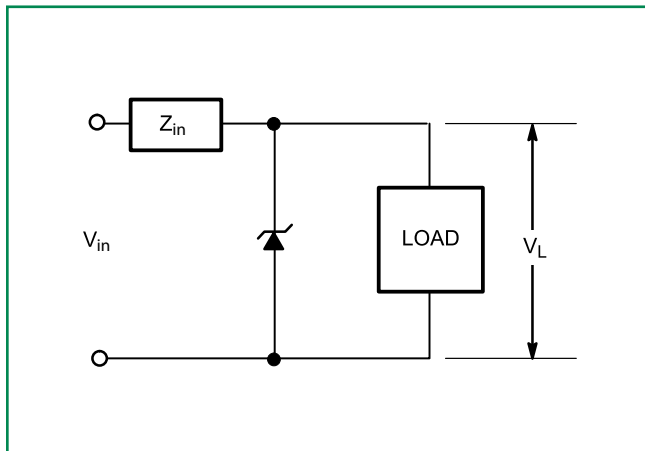
**Figure 8. Pulse Derating Curve**



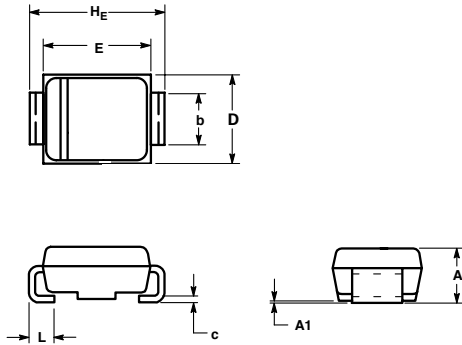
**Figure 9. Typical Junction Capacitance vs. Bias Voltage**



**Figure 10. Typical Protection Circuit**



**Dimensions**

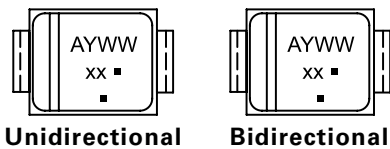


Dim	Inches			Millimeters		
	Min	Nom	Max	Min	Nom	Max
A	0.077	0.091	0.097	1.95	2.30	2.47
A1	0.002	0.004	0.008	0.05	0.10	0.20
b	0.077	0.080	0.087	1.96	2.03	2.20
c	0.006	0.09	0.012	0.15	0.23	0.31
D	0.130	0.140	0.156	3.30	3.56	3.95
E	0.160	0.170	0.181	4.06	4.32	4.60
HE	0.205	0.214	0.220	5.21	5.44	5.60
L	0.030	0.040	0.063	0.76	1.02	1.60
L1	0.020 REF			0.51 REF		

NOTES:

1. DIMENSIONING AND TOLERANCING PER ANSI Y14.5M, 1982.
2. CONTROLLING DIMENSION: INCH.
3. D DIMENSION SHALL BE MEASURED WITHIN DIMENSION P.

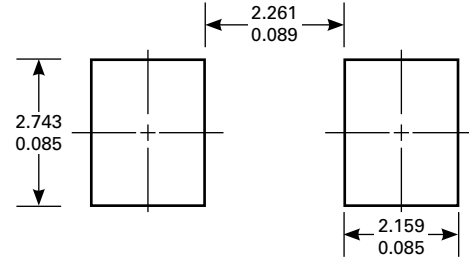
**Part Marking System**



- A = Assembly Location
- Y = Year
- WW = Work Week
- xx = Device Code (Refer to page 3)
- = Pb-Free Package

(Note: Microdot may be in either location)

**Soldering Footprint**



Scale 8:1 (  $\frac{\text{mm}}{\text{Inches}}$  )

**ORDERING INFORMATION**

Device**	Package	Shipping†
SZ1SMBxxAT3G	SMB (Pb-Free)	2,500 / Tape & Reel
SZ1SMBxxCAT3G	SMB (Pb-Free)	2,500 / Tape & Reel

**Flow/Wave Soldering (Solder Dipping)**

Peak Temperature :	260°C
Dipping Time :	10 seconds

**Physical Specifications**

Case	Void-free, transfer-molded, thermosetting plastic
Polarity	Cathode indicated by polarity band
Mounting Position	Any
Finish	All external surfaces are corrosion resistant and leads are readily solderable
Leads	Modified L-Bend providing more contact area to bond pads

**Disclaimer Notice** - Information furnished is believed to be accurate and reliable. However, users should independently evaluate the suitability of and test each product selected for their own applications. Littelfuse products are not designed for, and may not be used in, all applications. Read complete Disclaimer Notice at: [www.littelfuse.com/disclaimer-electronics](http://www.littelfuse.com/disclaimer-electronics).