

**MARKETING SALES DRAWING**  
**DIMENSIONS IN INCHES - DO NOT SCALE THIS DRAWING**  
**DIMENSIONS IN METRIC - [ ]**

Electrical Testing  
per Tusonix standard  
test plans and Mil-Std-202  
Test Methods.

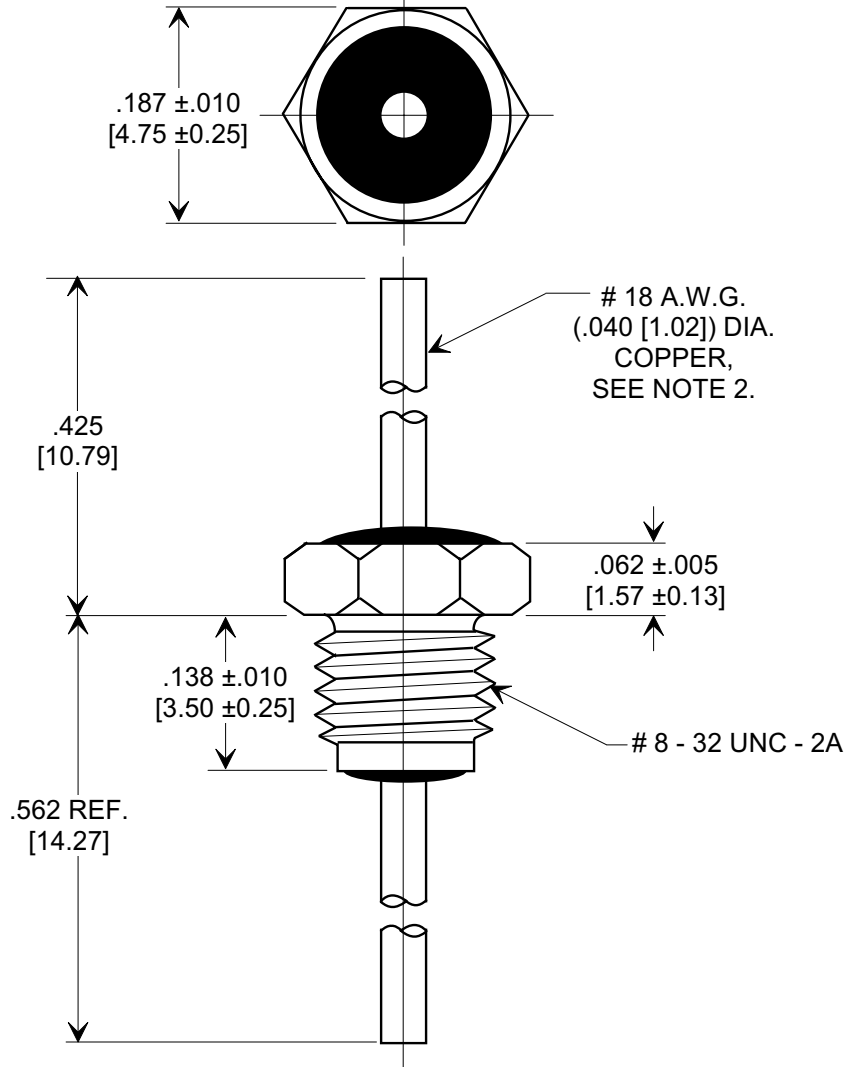
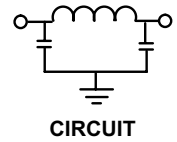
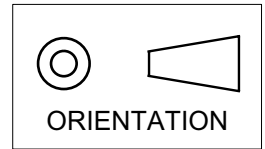

**NOTES:**

- TUSONIX STANDARD PART NUMBER: 4205-002.  
TUSONIX RoHS COMPLIANT PART NUMBER: 4205-002 LF.  
CUSTOMER MUST SPECIFY STANDARD OR RoHS PART NUMBER WHEN ORDERING.
- LEAD FINISH: STANDARD PART #: 60/40 SOLDER PLATED. RoHS PART #: SILVER PLATED.
- SILVER PLATED STEEL BUSHING.
- SILVER PLATED INTERNAL TOOTH LOCK WASHER AND #8-32 UNC-2B HEX NUT SUPPLIED.  
MAX. MOUNTING TORQUE 5 LB. INCHES [.565 N-m].
- PART MARKING: TRADEMARK AND VARIATION NUMBER ON HEX FLATS.  
STANDARD PART: BLACK INK. RoHS PART: GREEN INK.

MIN. CAP. (pF)	WORKING VOLTAGE (VWdc)		CURRENT Idc	I.R. MIN. @ 100 (VDC)	DWV (VDC)	MINIMUM NO LOAD INSERTION LOSS (dB) AT 25°C PER MIL-STD-220			
	85° C	125° C				10 MHz	100 MHz	1 GHz	10 GHz
65	250	125	15	10 G Ω	500	---	3	16	45

<b>X-2015 Rev-0</b> <b>REVISION RECORD</b> Original Release C.O. <b>20000711-11-01</b> REVISED NOTE & ADDED NOTES 2-5. S.M 07-26-05 <b>20050726-4-01</b> ADDED IR & DWV. S.M. 11-30-05 <b>20051102-4-03</b>	<b>0</b>	<b>BUSHING STYLE EMI FILTER</b>  Title Drawn L.E. 07-12-00 Scale 6 X Approved T.C. 07-12-00 <b>A</b> <b>4205-002</b>
	<b>--TOLERANCES--</b> Unless Otherwise Specified DECIMAL ± .031 [.79] ANGLES ±	
	<b>TUSONIX</b> TUCSON, ARIZONA	