

BASE CAGE DETAILS

(APPLIES TO ALL CAGES IN THIS DRAWING)

747683212 SHOWN

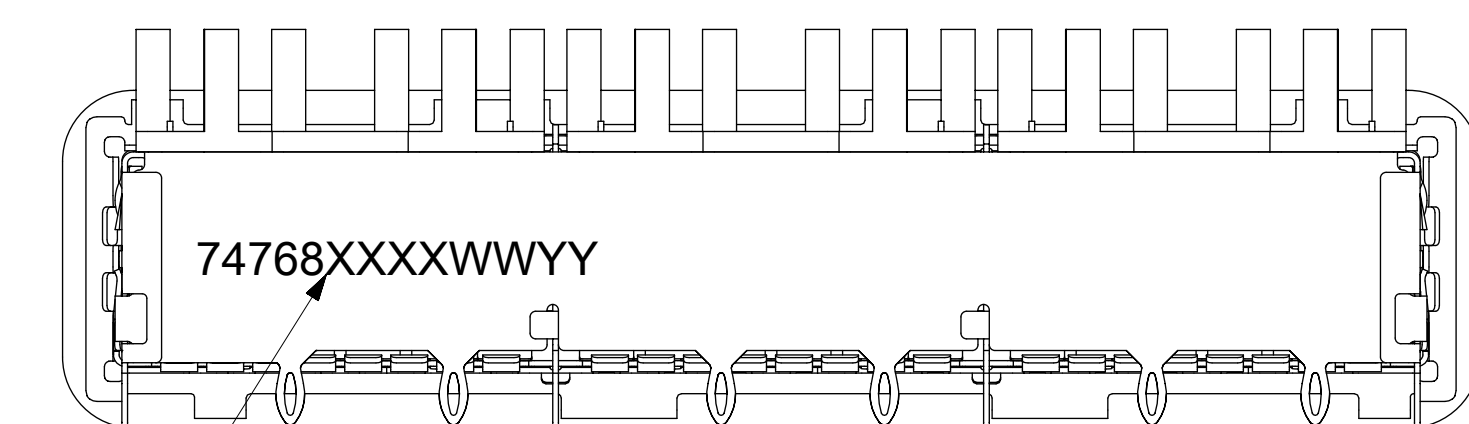
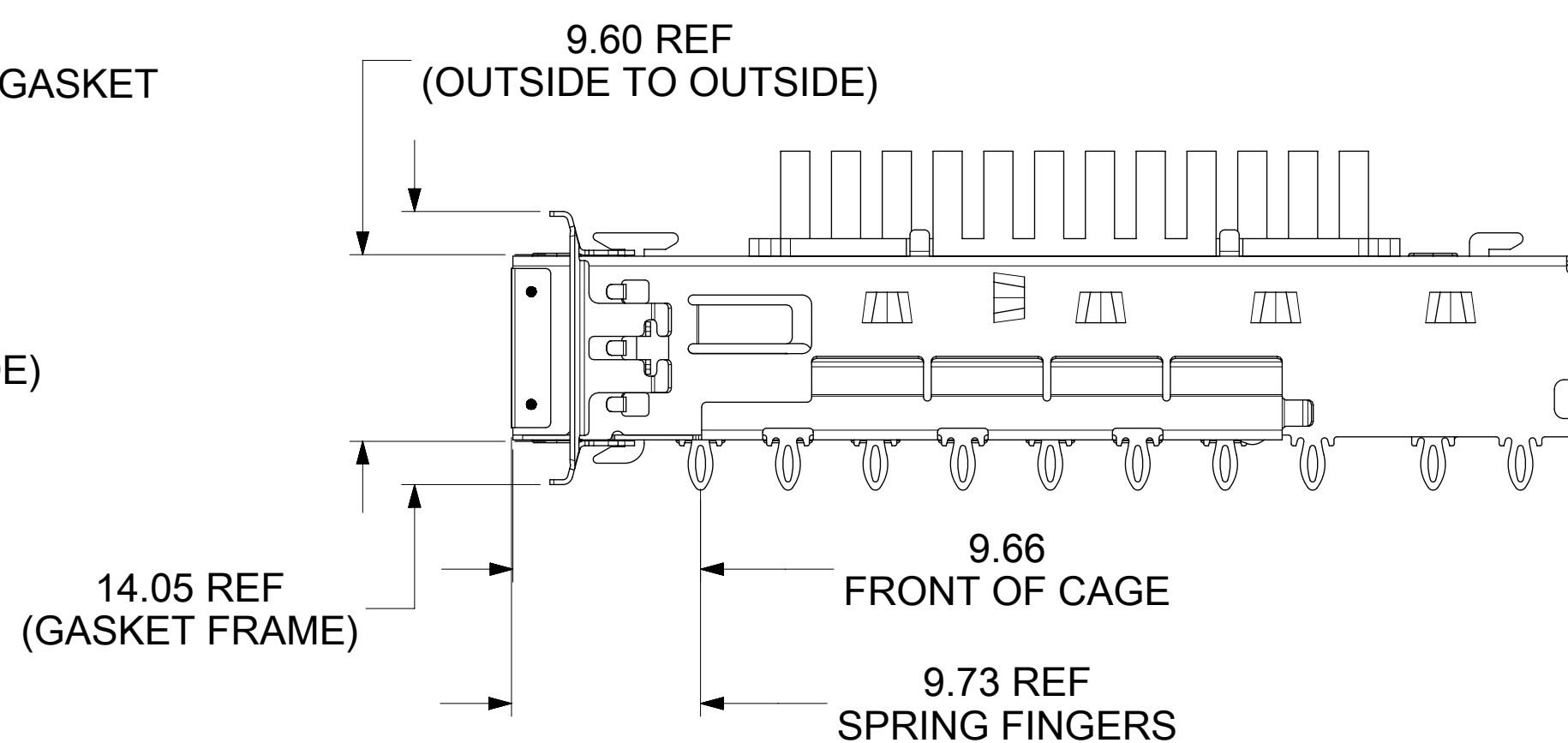
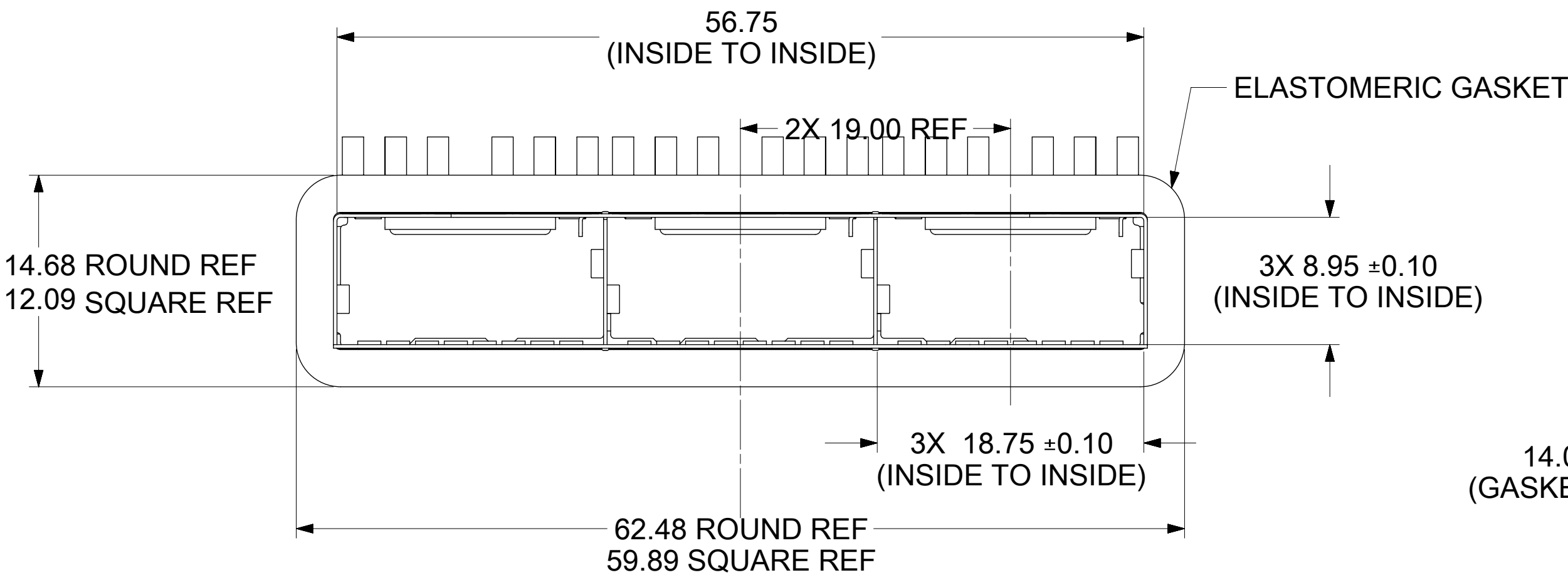
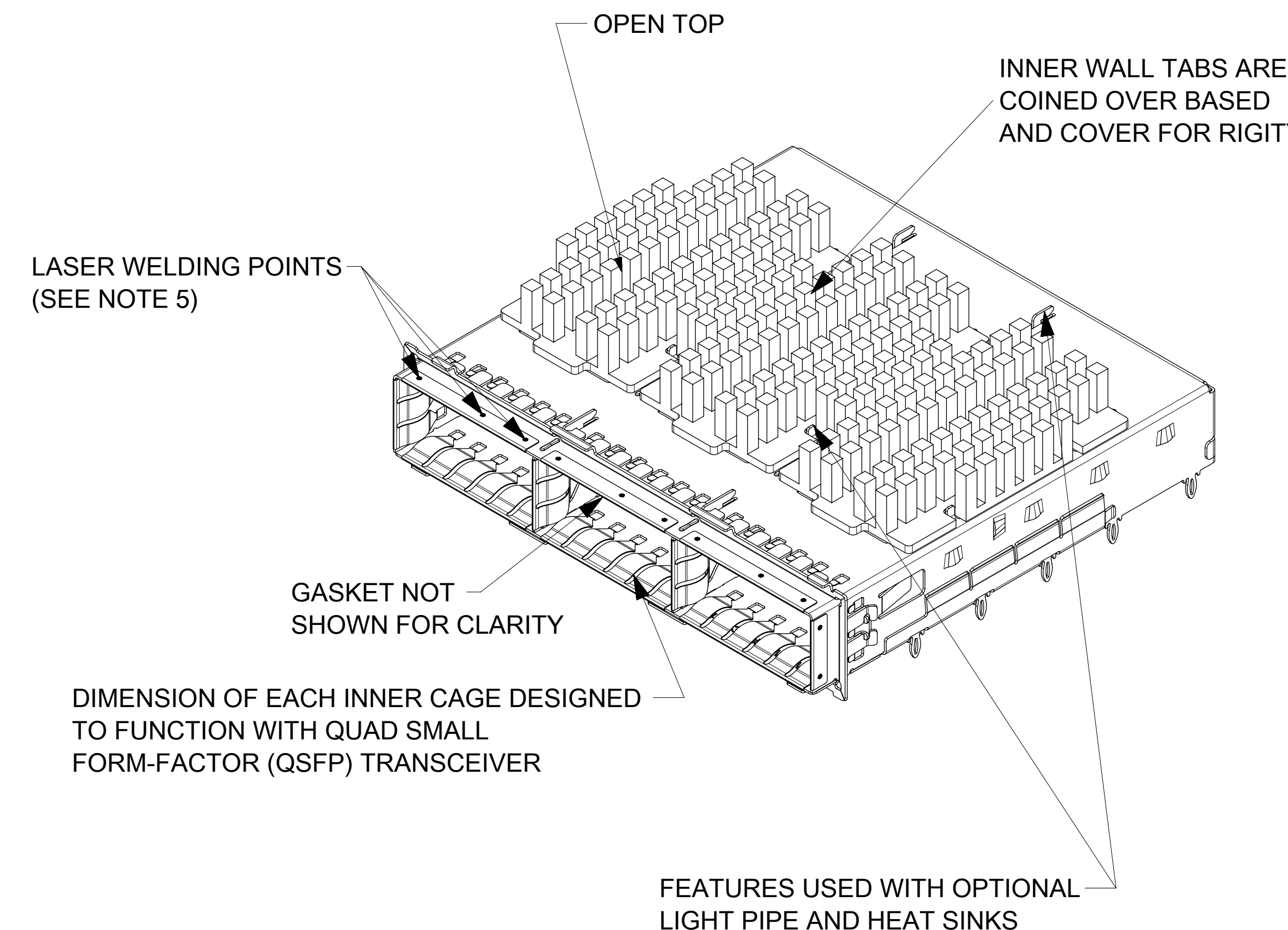
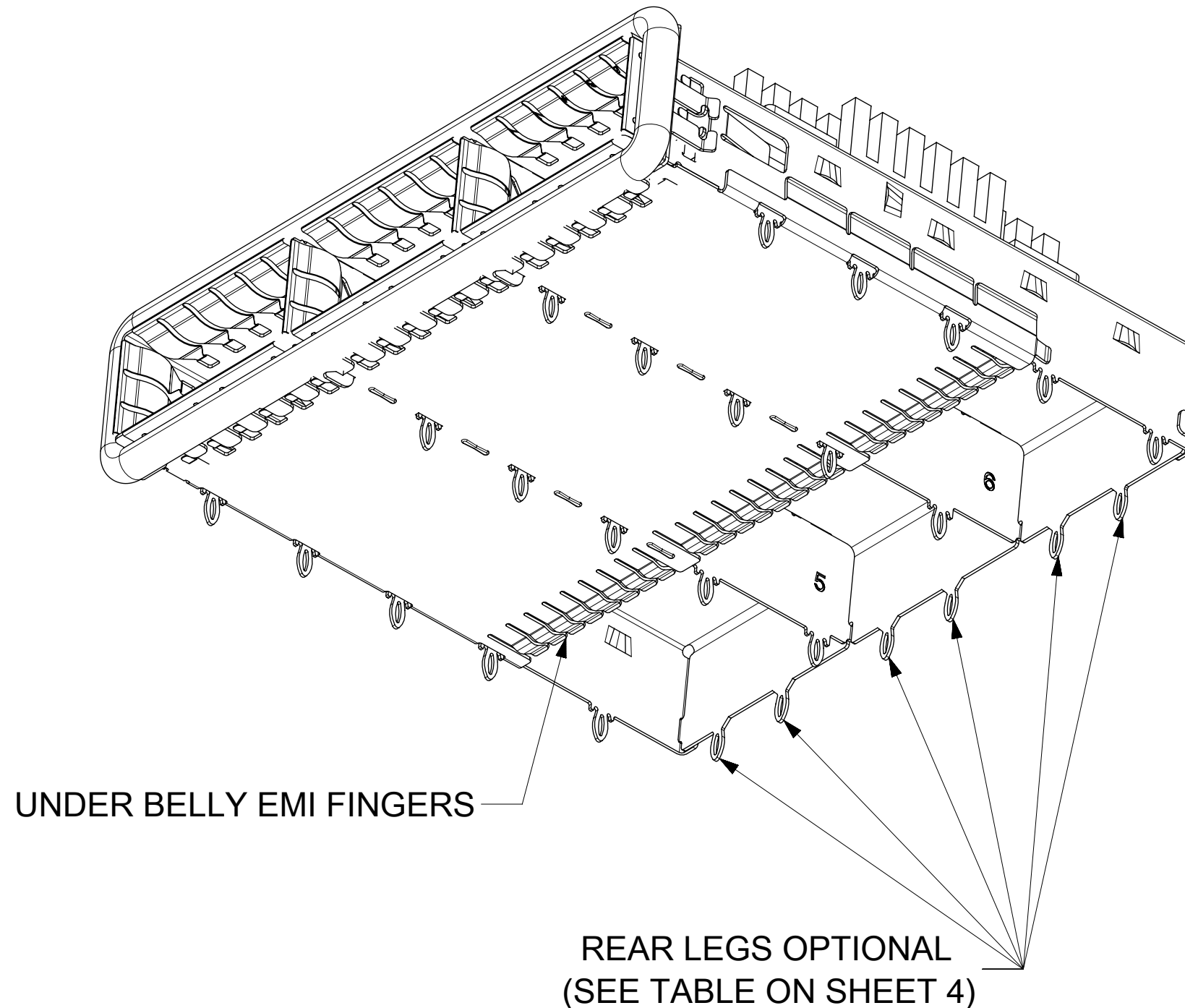
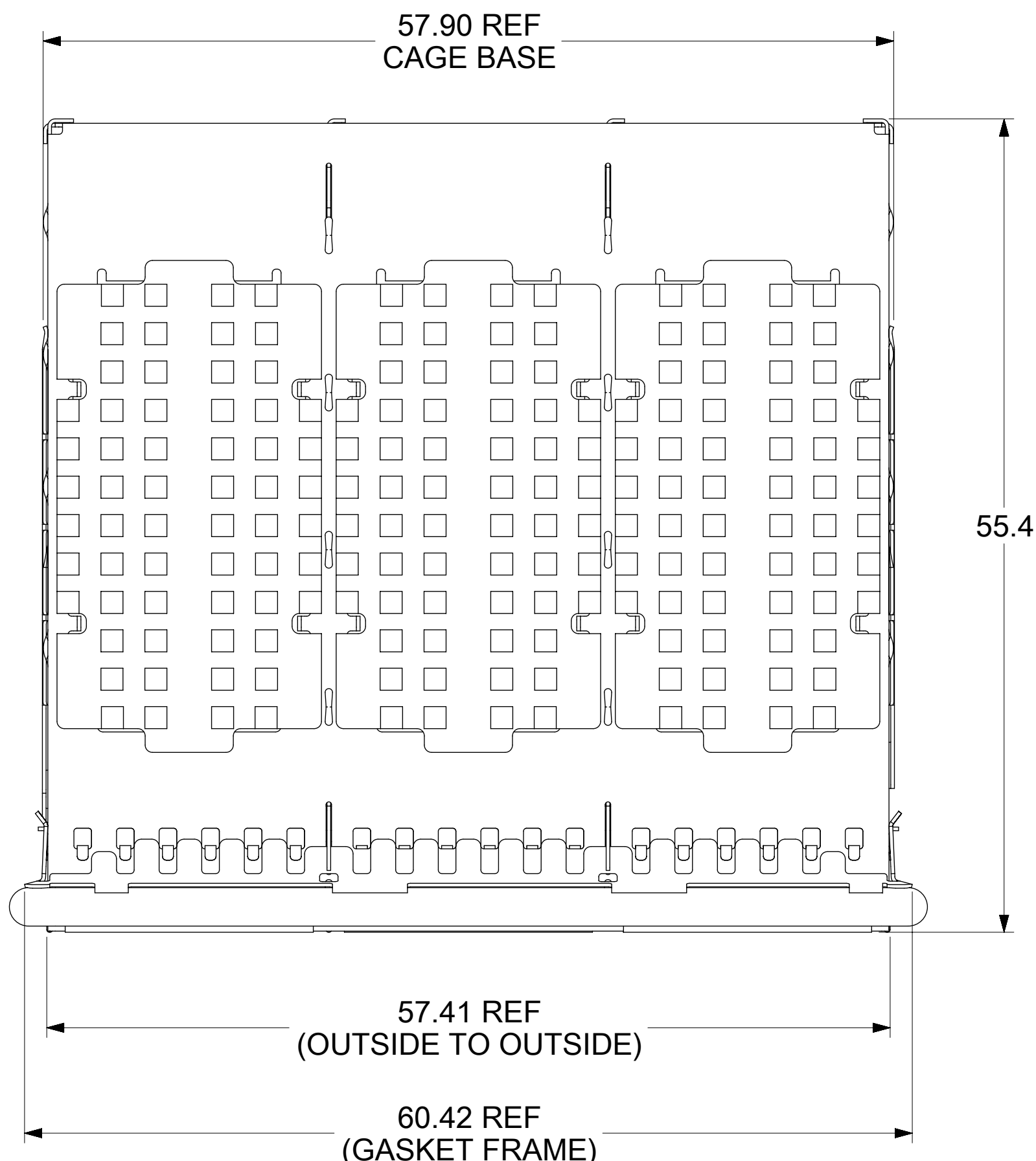

PART NO. AND WEEK/YEAR DATE CODE TO BE PRINTED ON BACK OF COMPLETED CAGE ASSEMBLY APPROXIMATELY AS SHOWN. SEE TABLE BELOW FOR DATE CODE INFORMATION.

NOTE: INNER SPRING FINGERS HAVE BEEN REMOVED FOR CLARITY

NOTE: ELASTOMER GASKET REMOVED FOR CLARITY

WEEK/YEAR DATE CODE TABLE	
WW	01 THRU 52 EXAMPLE: 01 = FIRST WEEK OF YEAR 52 = LAST WEEK OF YEAR
YY	23, 24, 25 ETC. EXAMPLE: YEAR 2023 =23

- NOTES:
1. QSFP+ ASSEMBLES ALSO AVAILABLE AND 1X1 74750 SERIES, 1X2 (74767 SERIES), 1X4 (74769 SERIES) AND 1X6 (74771 SERIES) CONFIGURATIONS.
 2. MATERIAL:
COVER: STAINLESS STEEL
LIGHT PIPES: POLYCARBONATE (94-V0 RATED)
SPRING FINGER : STAINLESS STEEL
CLIP: STAINLESS STEEL
HEAT SINKS: ALUMINUM
CAGE: COPPER ALLOY
GASKET MATERIAL : ELASTOMER GASKET SILICONE, COLOUR BLACK
 3. NO RoHS EXEMPTIONS
 4. CUSTOM HEATSINKS AVAILABLE UPON REQUEST.
 5. WELD SPOTS MAY SHOW SLIGHT MATERIAL DISCOLORATION.

THIS DRAWING CONTAINS INFORMATION THAT IS PROPRIETARY TO MOLEX ELECTRONIC TECHNOLOGIES, LLC AND SHOULD NOT BE USED WITHOUT WRITTEN PERMISSION									
DIMENSION UNITS	SCALE	CURRENT REV DESC:							
mm	3:1								
GENERAL TOLERANCES (UNLESS SPECIFIED)									
ANGULAR TOL	± 1.0°								
4 PLACES	±	EC NO: 744377							
3 PLACES	±	DRWN: DKUMARG		2023/03/29					
2 PLACES	± 0.15	CHK'D: AMRUTH		2023/03/30					
1 PLACE	± 0.25	APPR: TKUMARKC		2023/03/31					
0 PLACES	±	INITIAL REVISION:							
DRAFT WHERE APPLICABLE MUST REMAIN WITHIN DIMENSIONS		DRWN: CHETHH2		2022/05/25					
		APPR: SCHIEN		2022/07/07					
		THIRD ANGLE PROJECTION	DRAWING	SERIES	MATERIAL NUMBER	CUSTOMER	SHEET NUMBER		
			D-SIZE	74768	SEE P/N TABLE		1 OF 7		

molex

QSFP+ 1X3 GANGED CAGE, GASKET TYPE W/ SUS INNER SPRING FINGER

PRODUCT CUSTOMER DRAWING

DOCUMENT NUMBER: 747683506
DOC TYPE: PSD
DOC PART: ASY
REVISION: A1

CAGE ASSEMBLY OPTIONS

747683506 SHOWN

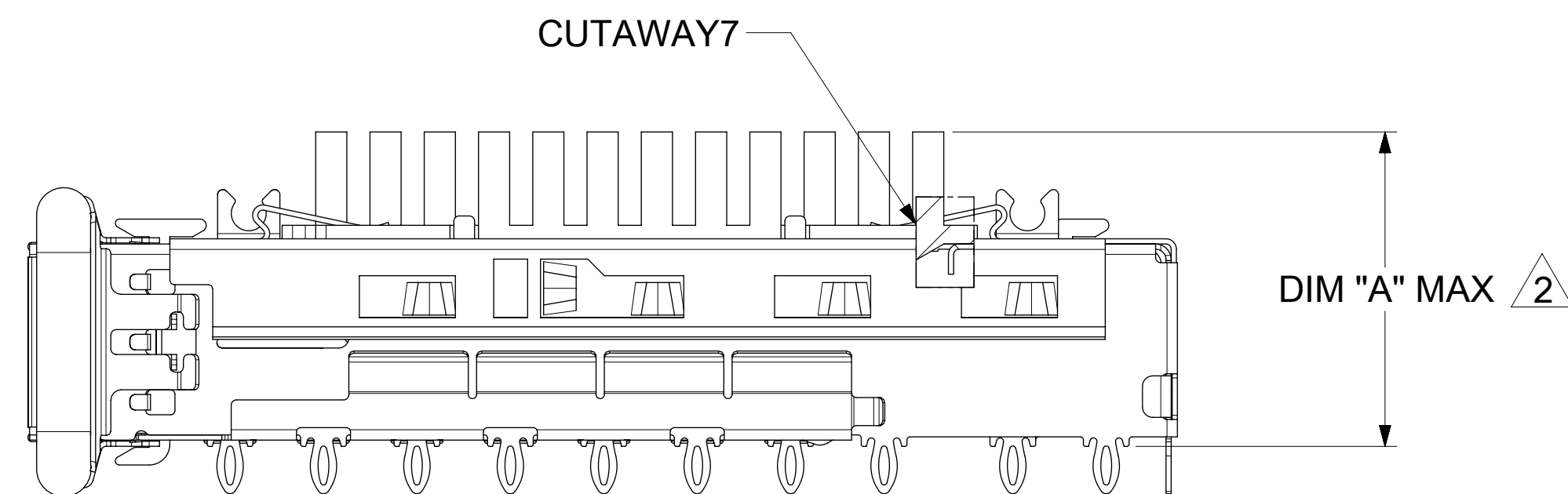
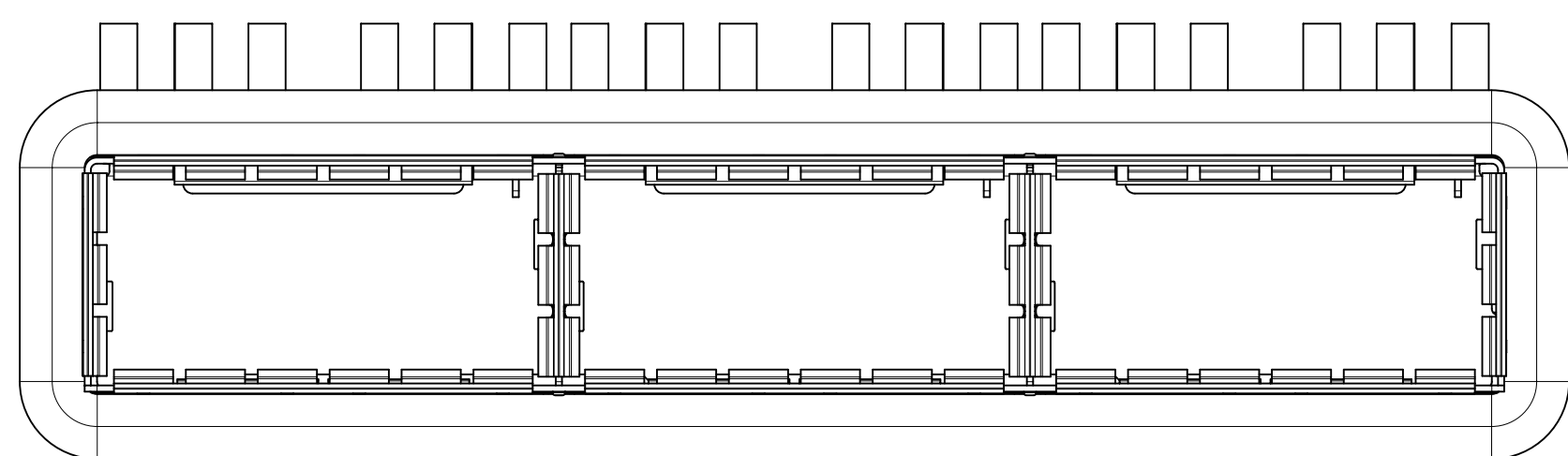
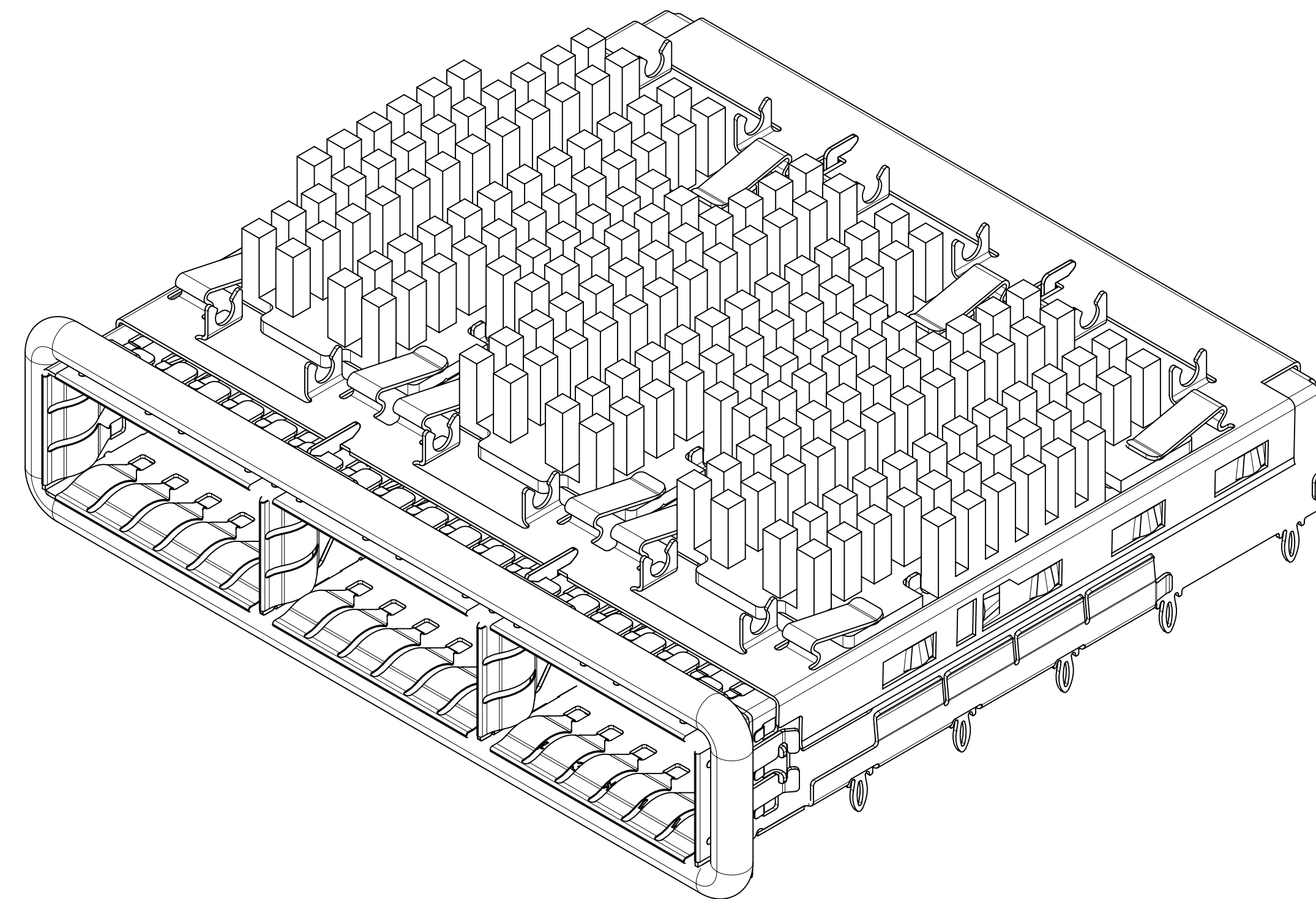
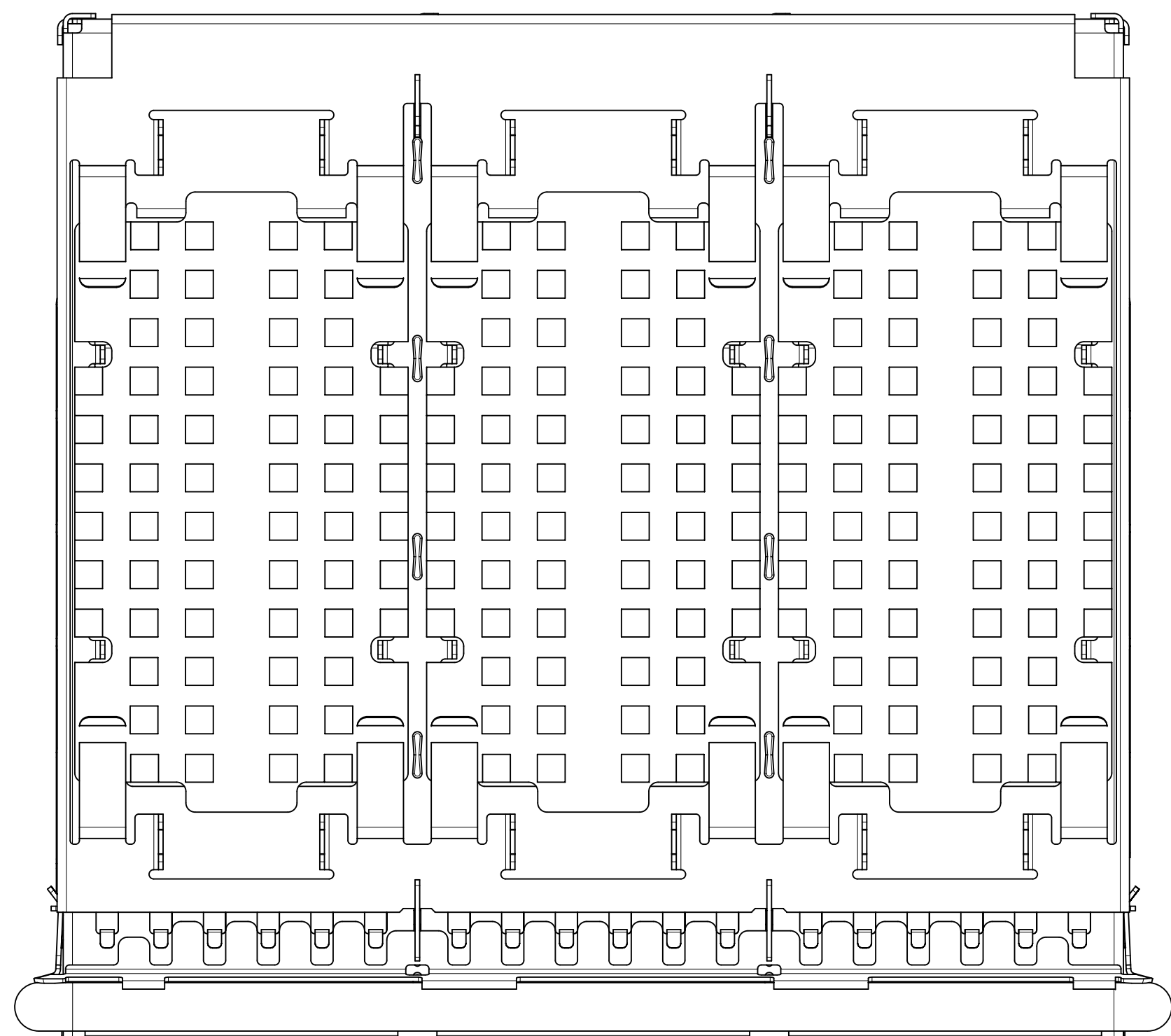

HEATSINK HEIGHT OPTIONS

OVERALL HEATSINK HEIGHT	DIM "A"
SAN	16.0

SAN HEAT SINK
(PIN STYLE)

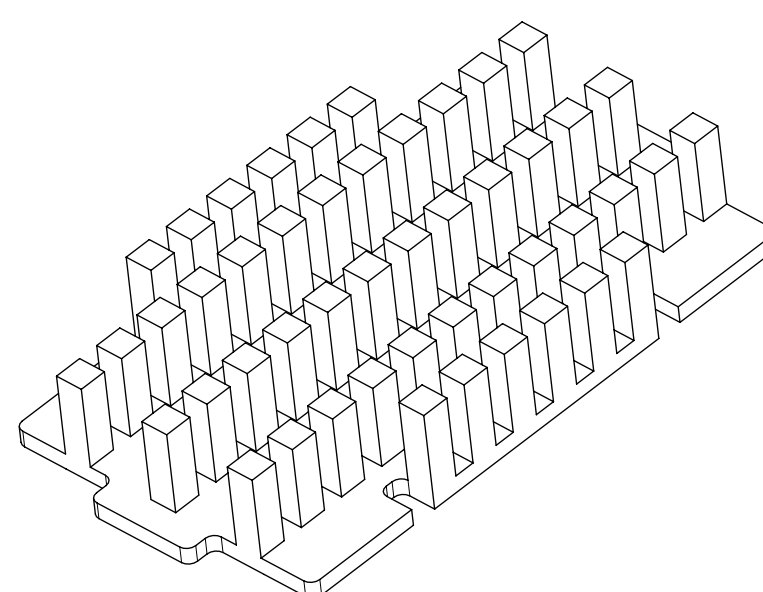

HEIGHT OF HEATSINK WITH MODULE INSERTED.
DIMENSION MAY BE LESS DUE TO MODULE AND HEATSINK VARIATIONS.

THIS DRAWING CONTAINS INFORMATION THAT IS PROPRIETARY TO MOLEX ELECTRONIC TECHNOLOGIES, LLC AND SHOULD NOT BE USED WITHOUT WRITTEN PERMISSION									
DIMENSION UNITS	SCALE	CURRENT REV DESC:							
mm	3.5:1								
GENERAL TOLERANCES (UNLESS SPECIFIED)									
ANGULAR TOL	± 1.0°								
4 PLACES	±	EC NO: 744377							
3 PLACES	±	DRWN: DKUMARG 2023/03/29							
2 PLACES	± 0.15	CHK'D: AMRUTH 2023/03/30							
1 PLACE	± 0.25	APPR: TKUMARKC 2023/03/31							
0 PLACES	±	INITIAL REVISION:							
DRAFT WHERE APPLICABLE MUST REMAIN WITHIN DIMENSIONS		THIRD ANGLE PROJECTION		DRAWING		SERIES		MATERIAL NUMBER	
		D-SIZE		74768		SEE P/N TABLE		CUSTOMER	
								SHEET NUMBER	
								2 OF 7	

molex

QSFP+ 1X3 GANGED CAGE, GASKET TYPE
W/ SUS INNER SPRING FINGER

PRODUCT CUSTOMER DRAWING

DOCUMENT NUMBER DOC TYPE DOC PART REVISION

747683506 PSD ASY A1

MATERIAL NUMBER CUSTOMER SHEET NUMBER

SEE P/N TABLE 2 OF 7

NOTE:
1. FOR LIGHT PIPE OPTIONS SEE SHEET 3.
2. HEIGHT OF HEATSINK WITH MODULE INSERTED.
DIMENSION MAY BE LESS DUE TO MODULE AND HEATSINK VARIATIONS.

DOCUMENT STATUS	P1	RELEASE DATE	2023/03/31	10:58:52
-----------------	----	--------------	------------	----------

PART NUMBER SELECTION

NO HEAT SINKS
NO LIGHT PIPES

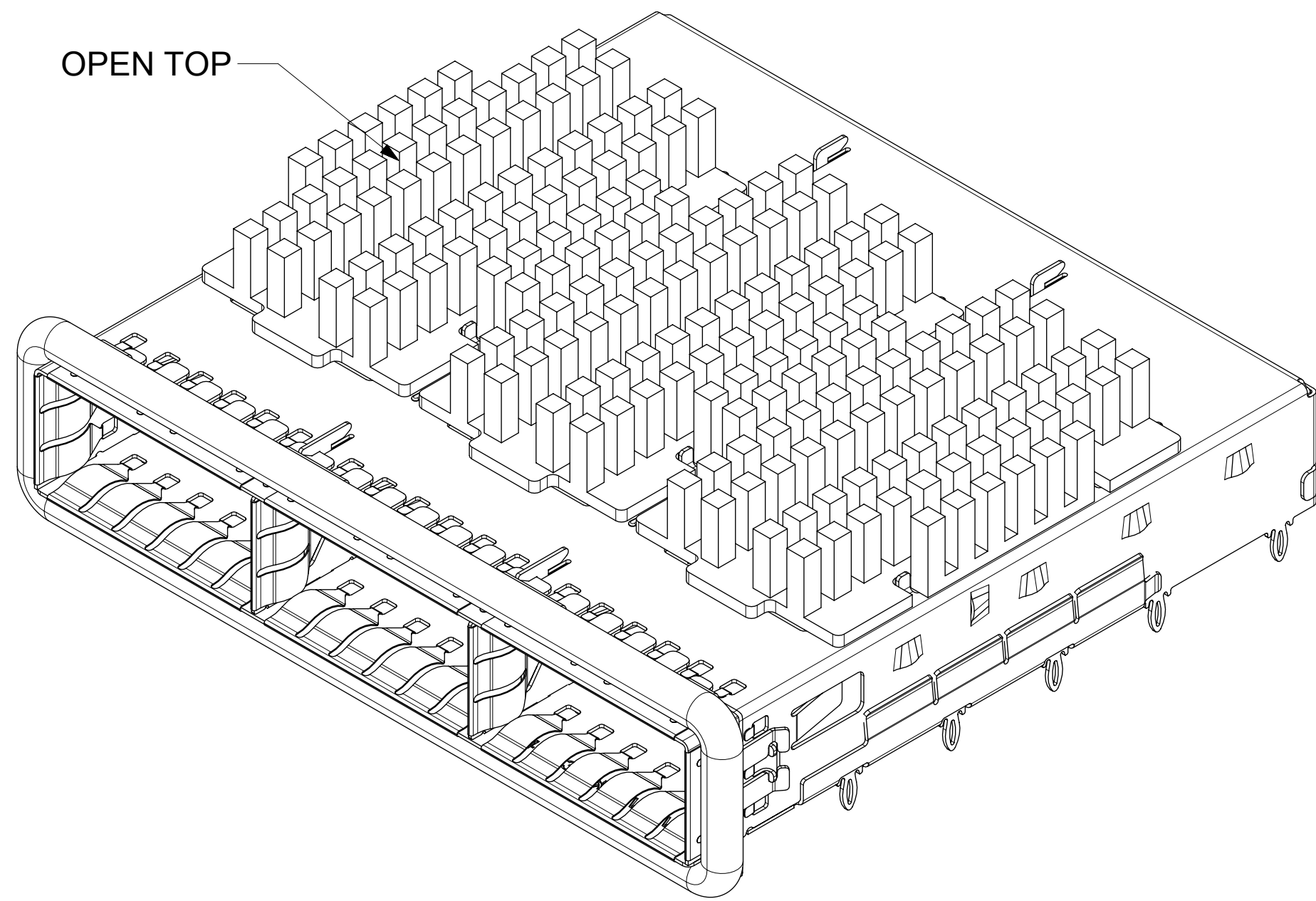

WITH HEAT SINKS
NO LIGHT PIPES

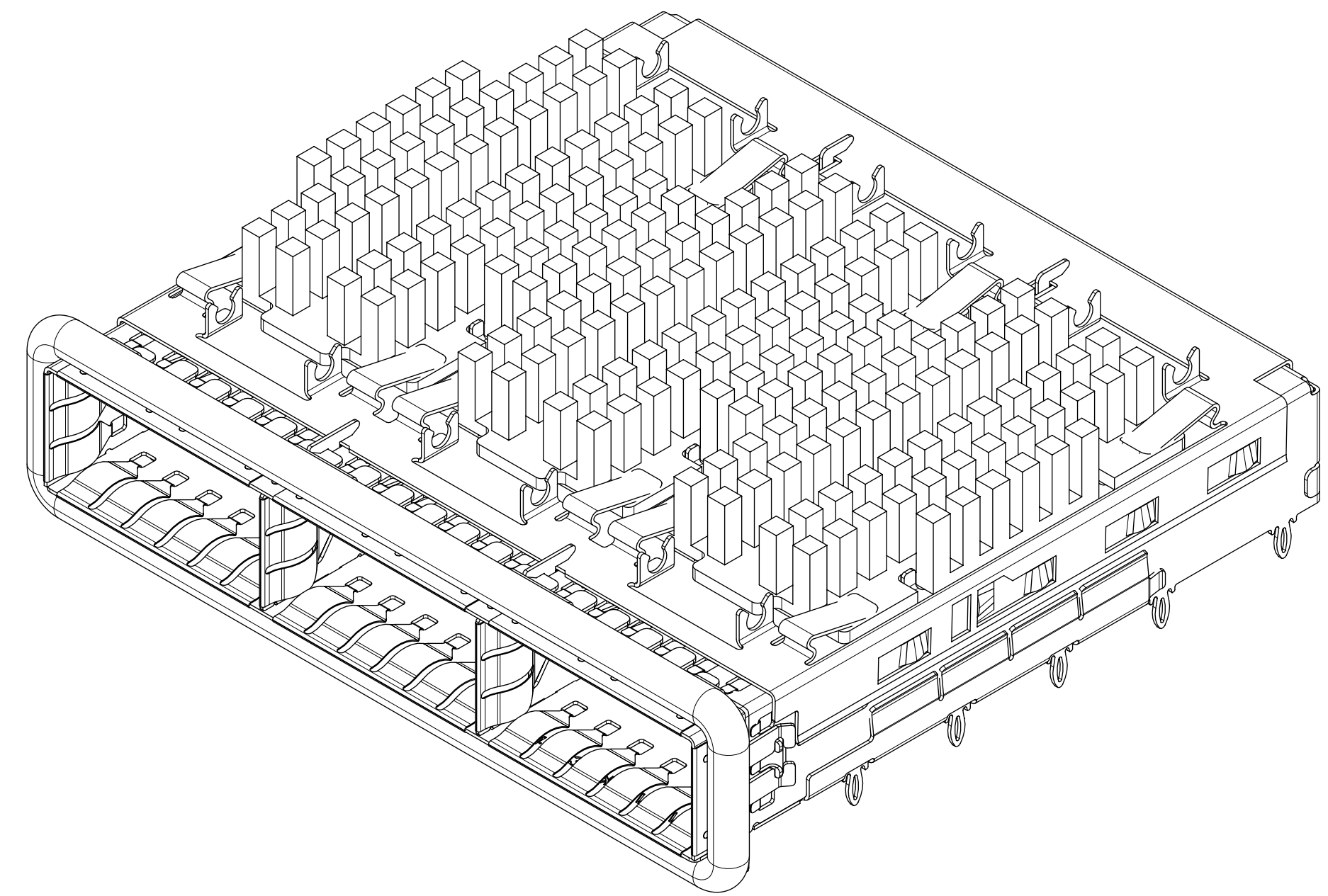

MOLEX P/N	GASKET STYLE	# OF REAR LEGS PER PORT
747683210	ROUND	0
747683212	ROUND	2

MOLEX P/N	GASKET STYLE	HS	# OF REAR LEGS PER PORT
747683506	ROUND	SAN	2

REAR LEG OPTIONS

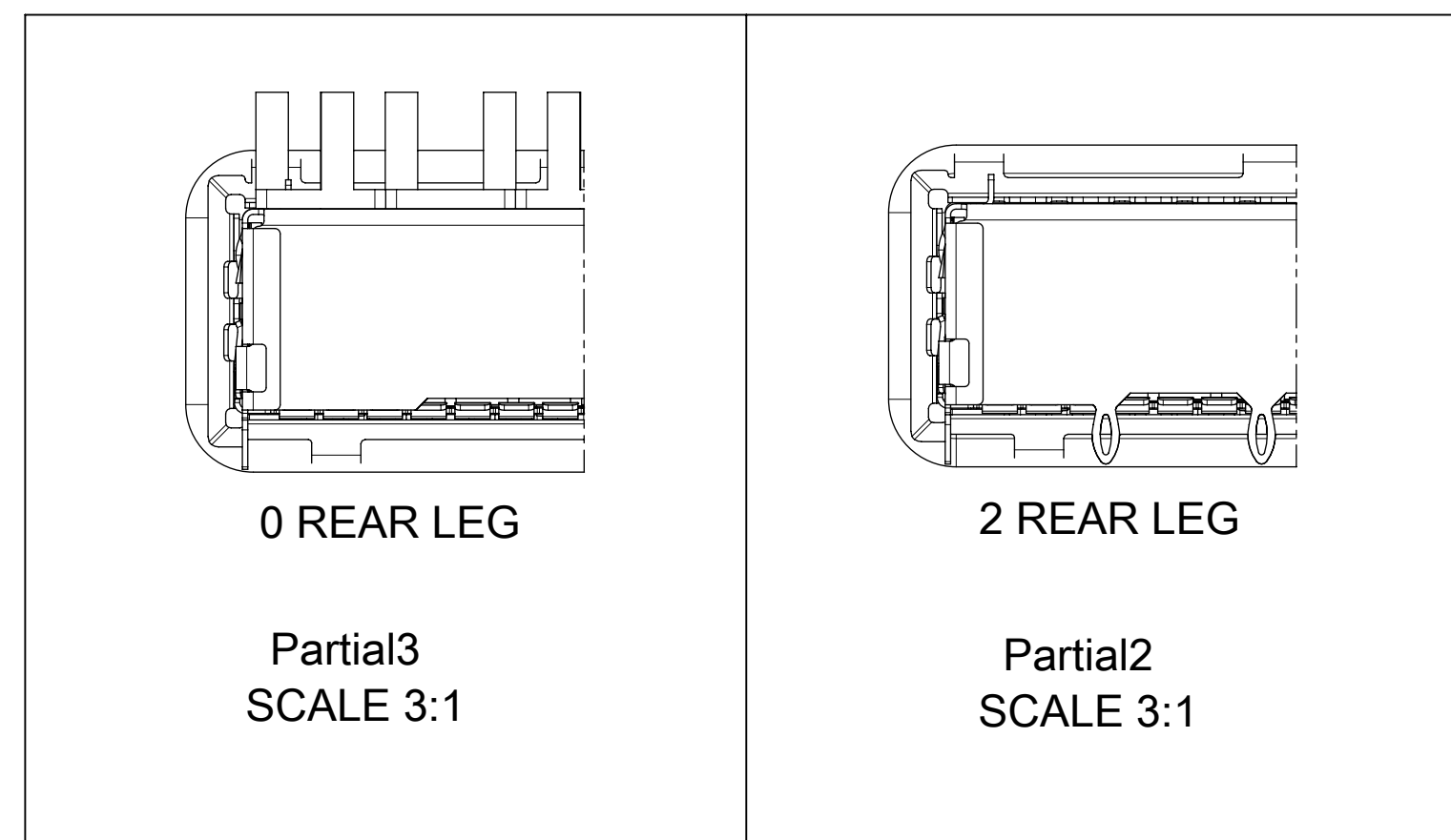

ELASTOMERIC GASKET OPTIONS

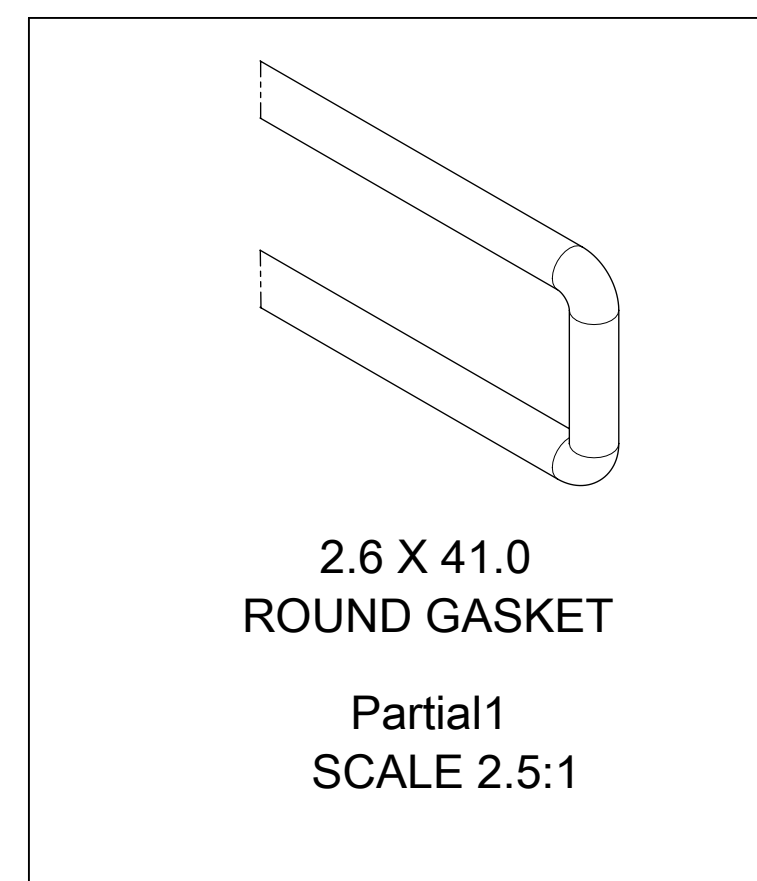

THIS DRAWING CONTAINS INFORMATION THAT IS PROPRIETARY TO MOLEX ELECTRONIC TECHNOLOGIES, LLC AND SHOULD NOT BE USED WITHOUT WRITTEN PERMISSION									
DIMENSION UNITS	SCALE	CURRENT REV DESC:							
mm	3:1								
GENERAL TOLERANCES (UNLESS SPECIFIED)		EC NO: 744377			QSFP+ 1X3 GANGED CAGE, GASKET TYPE W/ SUS INNER SPRING FINGER PRODUCT CUSTOMER DRAWING				
ANGULAR TOL	± 1.0°	DRWN: DKUMARG 2023/03/29							
4 PLACES	±	CHK'D: AMRUTH 2023/03/30			DOCUMENT NUMBER: 747683506 DOC TYPE: PSD DOC PART: ASY REVISION: A1				
3 PLACES	±	APPR: TKUMARKC 2023/03/31							
2 PLACES	± 0.15	INITIAL REVISION:			MATERIAL NUMBER: 74768 CUSTOMER: SEE P/N TABLE SHEET NUMBER: 3 OF 7				
1 PLACE	± 0.25	DRWN: CHETHH2 2022/05/25							
0 PLACES	±	APPR: SCHIEN 2022/07/07			DRAFT WHERE APPLICABLE MUST REMAIN WITHIN DIMENSIONS				
THIRD ANGLE PROJECTION		DRAWING	SERIES						
			D-SIZE	74768					

PCB LAYOUT FOR SINGLE SIDED MOUNTING

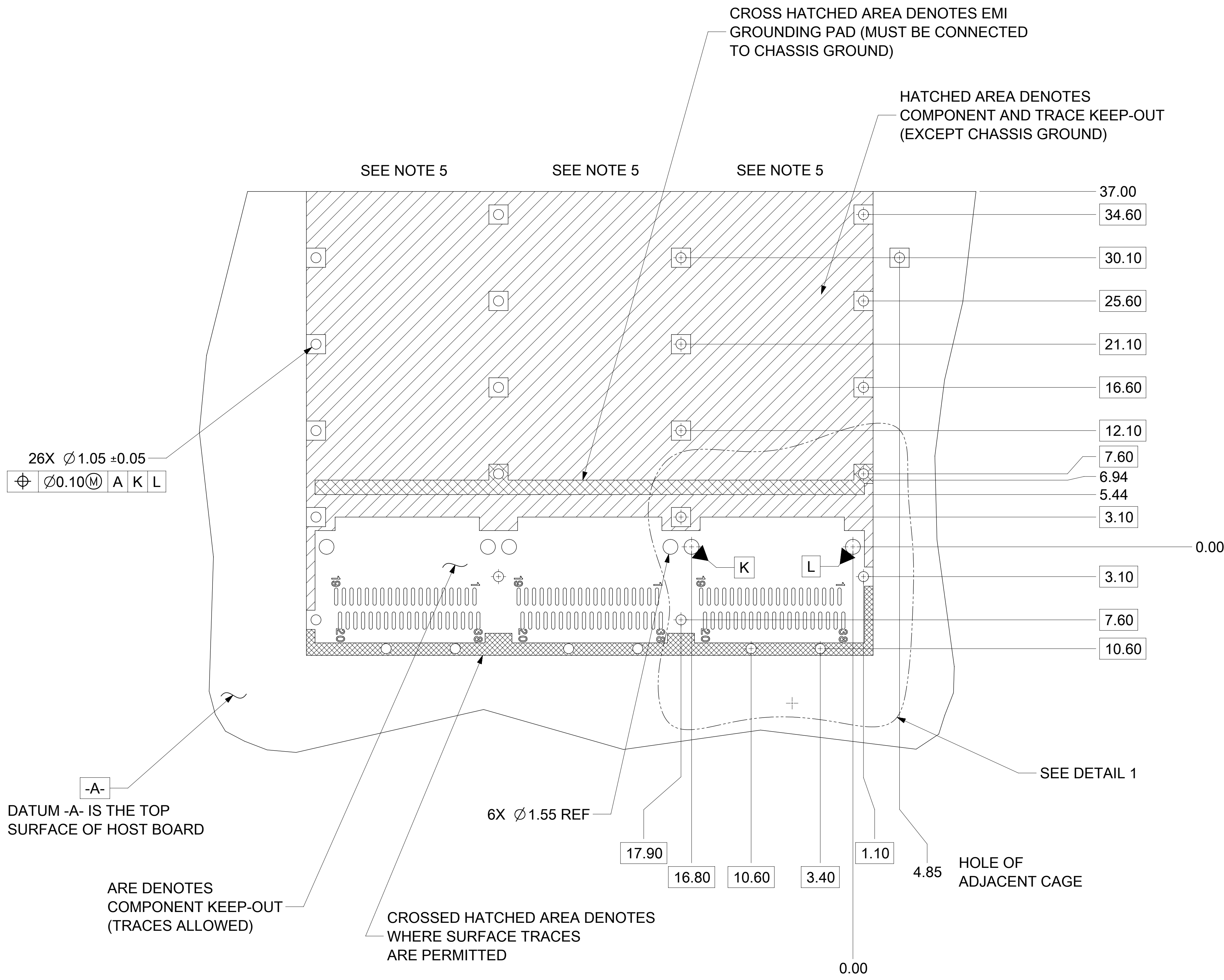

HOST CONNECTOR DETAIL

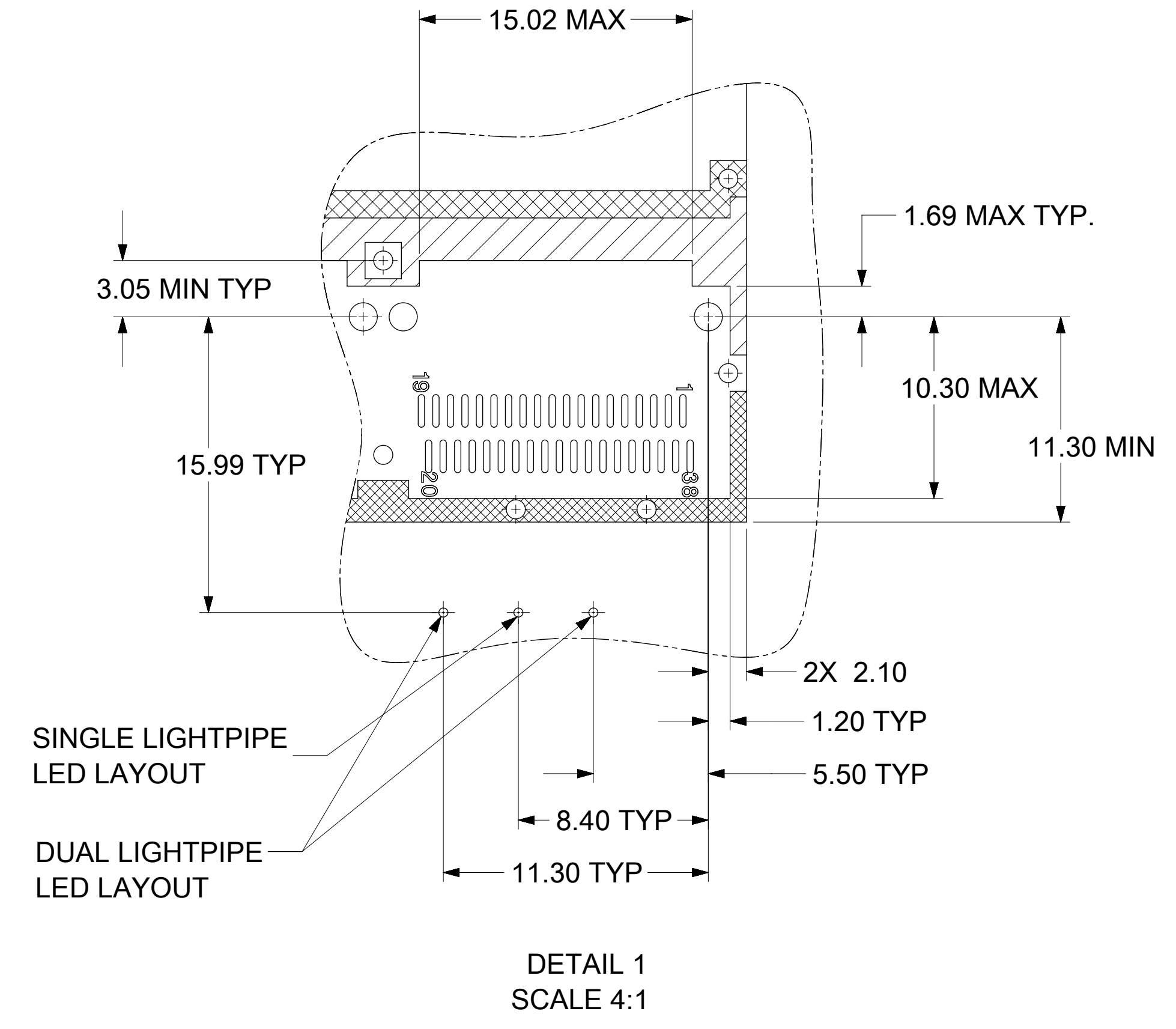

- NOTES:
- PADS AND VIAS CONNECT TO CHASSIS GROUND (RECOMMEND PADS TO BE 2.00mm SQUARE)
 - RECOMMENDED THRU HOLE PLATING INCLUDES HASL, OSP, OR IMMERSION (GOLD, SILVER, OR TIN).
 - CONNECTOR PAD LAYOUT PER QSFP MSA WILL ACCOMODATE MOLEX CONNECTOR 75586-0010 OR 75586-0011.
 - SINGLE SIDE BOARD THICKNESS:
NONIMAL: 1.60
MINIMUM: 1.44
 - SPACING BETWEEN PORTS IS 19.00
 - LED SHOULD BE PLACED RELATIVE TO THE QSFP CONNECTOR POST HOLES

THIS DRAWING CONTAINS INFORMATION THAT IS PROPRIETARY TO MOLEX ELECTRONIC TECHNOLOGIES, LLC AND SHOULD NOT BE USED WITHOUT WRITTEN PERMISSION									
DIMENSION UNITS	SCALE	CURRENT REV DESC:							
mm	4:1								
GENERAL TOLERANCES (UNLESS SPECIFIED)									
ANGULAR TOL	± 1.0°								
4 PLACES	±	EC NO: 744377							
3 PLACES	±	DRWN: DKUMARG 2023/03/29							
2 PLACES	± 0.15	CHK'D: AMRUTH 2023/03/30							
1 PLACE	± 0.25	APPR: TKUMARKC 2023/03/31							
0 PLACES	±	INITIAL REVISION:							
DRAFT WHERE APPLICABLE MUST REMAIN WITHIN DIMENSIONS		THIRD ANGLE PROJECTION		DRAWING		SERIES		MATERIAL NUMBER	
		D-SIZE		74768		SEE P/N TABLE		CUSTOMER	
DOCUMENT STATUS		P1		RELEASE DATE		2023/03/31		10:58:52	

molex

QSFP+ 1X3 GANGED CAGE, GASKET TYPE
W/ SUS INNER SPRING FINGER

PRODUCT CUSTOMER DRAWING

DOCUMENT NUMBER: **747683506**

DOC TYPE: PSD ASY A1

SHEET NUMBER: 4 OF 7

PCB LAYOUT FOR BELLY TO BELLY MOUNTING

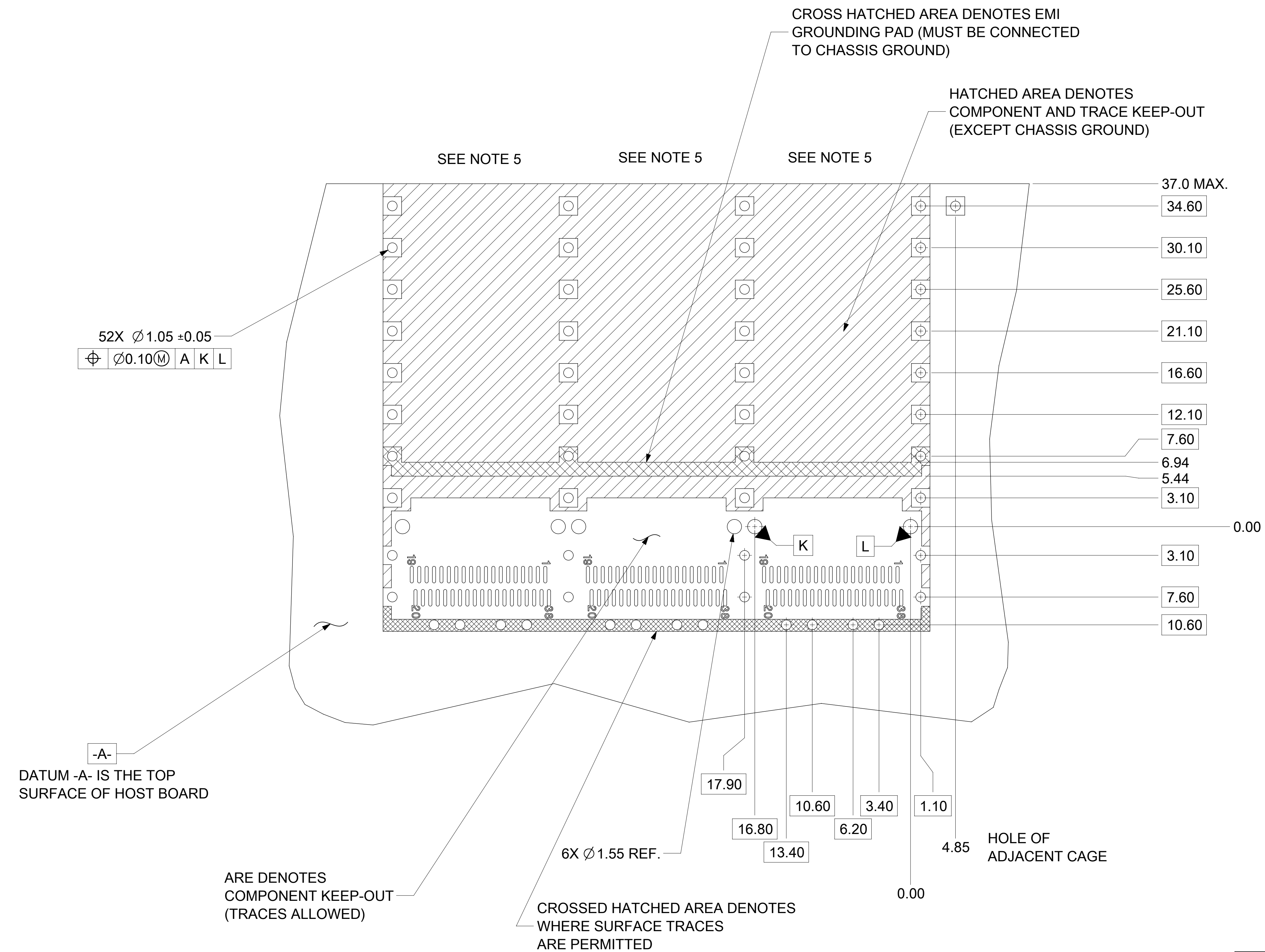

NOTE:
SEE PREVIOUS SHEET 4 FOR
HOST CONNECTOR AND
LED LOCATION DETAILS

- NOTES:
- PADS AND VIAS CONNECT TO CHASSIS GROUND (RECOMMEND PADS TO BE 2.00mm SQUARE)
 - RECOMMENDED THRU HOLE PLATING INCLUDES HASL, OSP, OR IMMERSION (GOLD, SILVER, OR TIN).
 - CONNECTOR PAD LAYOUT PER QSFP MSA WILL ACCOMODATE MOLEX CONNECTOR 75586-0010 OR 75586-0011.
 - BELLY TO BELLY BOARD THICKNESS:
NONIMAL: 2.90
MINIMUM: 2.48
 - SPACING BETWEEN PORTS IS 19.00

THIS DRAWING CONTAINS INFORMATION THAT IS PROPRIETARY TO MOLEX ELECTRONIC TECHNOLOGIES, LLC AND SHOULD NOT BE USED WITHOUT WRITTEN PERMISSION									
DIMENSION UNITS	SCALE	CURRENT REV DESC:							
mm	4:1	<p>molex</p> <p>QSFP+ 1X3 GANGED CAGE, GASKET TYPE W/ SUS INNER SPRING FINGER</p> <p>PRODUCT CUSTOMER DRAWING</p> <p>DOCUMENT NUMBER: 747683506 DOC TYPE: PSD DOC PART: ASY REVISION: A1</p> <p>EC NO: 744377 DRWN: DKUMARG 2023/03/29 CHK'D: AMRUTH 2023/03/30 APPR: TKUMARKC 2023/03/31</p> <p>INITIAL REVISION: DRWN: CHETHH2 2022/05/25 APPR: SCHIEN 2022/07/07</p> <p>DRAFT WHERE APPLICABLE MUST REMAIN WITHIN DIMENSIONS</p>							
GENERAL TOLERANCES (UNLESS SPECIFIED)									
ANGULAR TOL	± 1.0°								
4 PLACES	±								
3 PLACES	±								
2 PLACES	± 0.15								
1 PLACE	± 0.25								
0 PLACES	±								
THIRD ANGLE PROJECTION		DRAWING	SERIES	MATERIAL NUMBER	CUSTOMER	SHEET NUMBER			
DRAFT WHERE APPLICABLE MUST REMAIN WITHIN DIMENSIONS		THIRD ANGLE PROJECTION	D-SIZE	74768	SEE P/N TABLE	5 OF 7			

BOARD AND BEZEL POSITION DIMENSIONS FOR BELLY TO BELLY MOUNTING

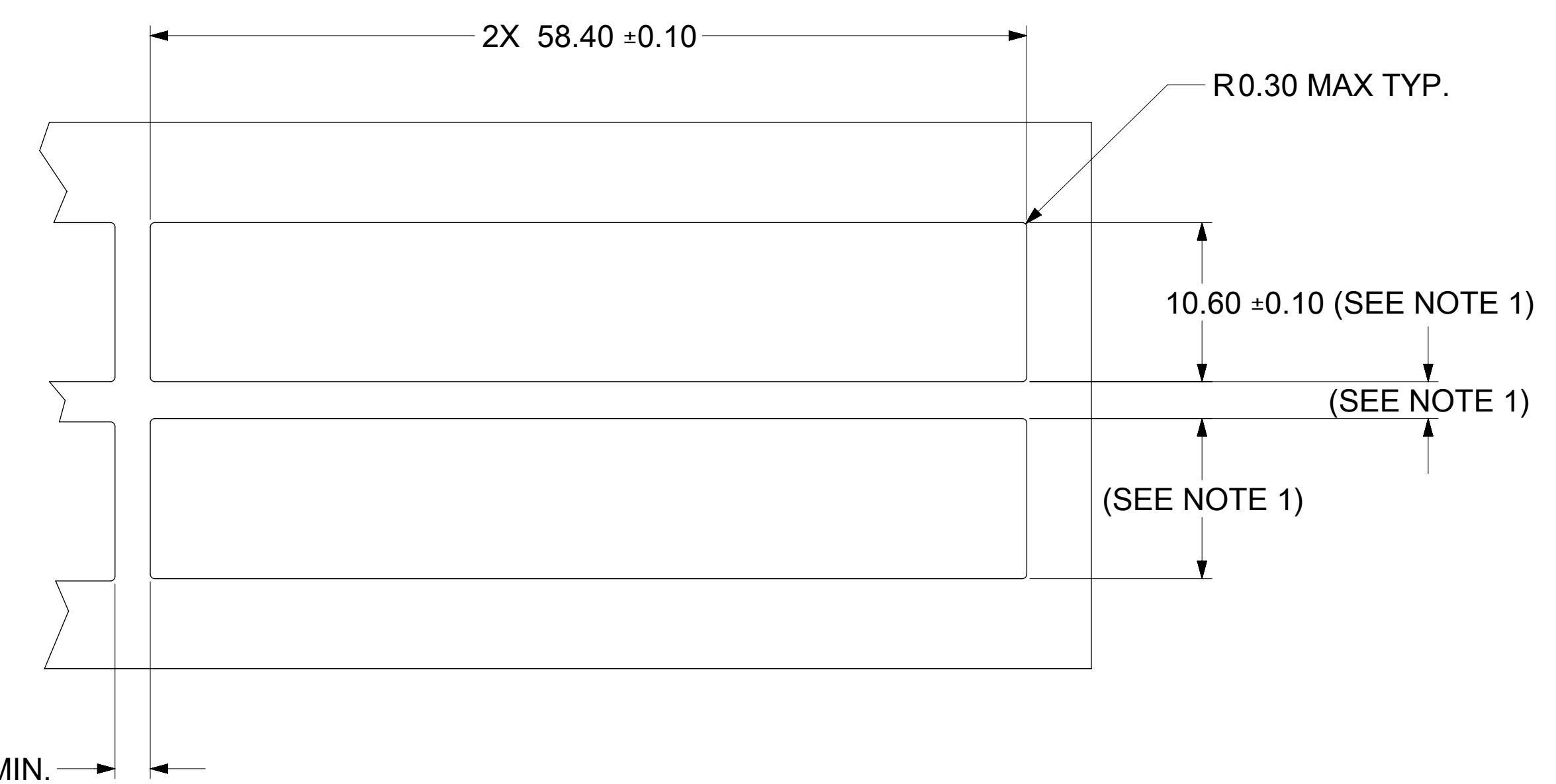
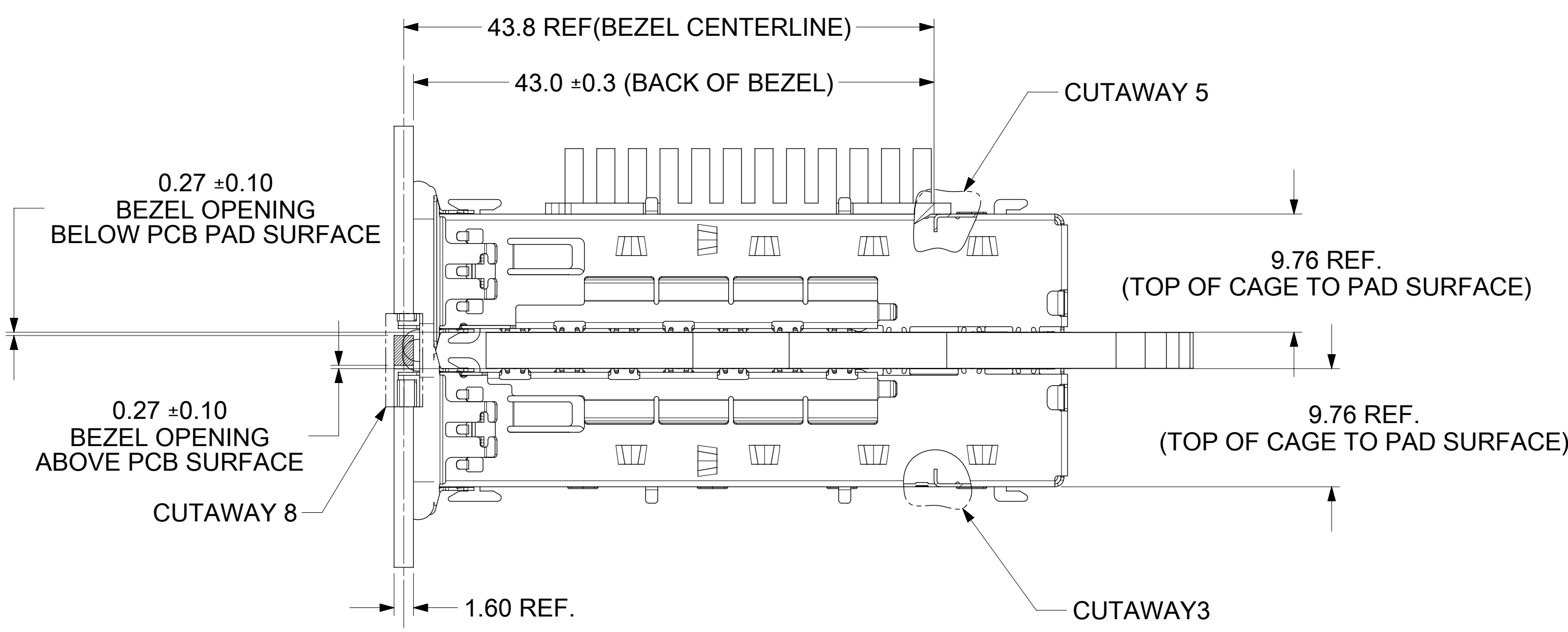

BOARD AND BEZEL POSITION DIMENSIONS FOR SINGLE SIDE MOUNTING

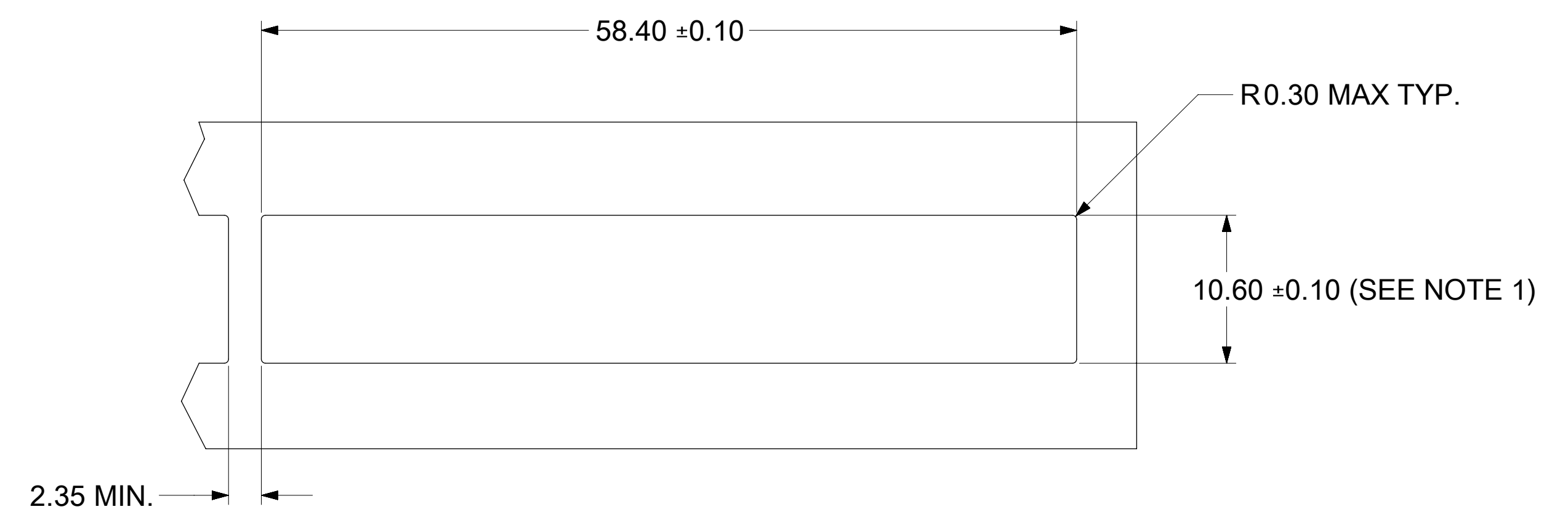
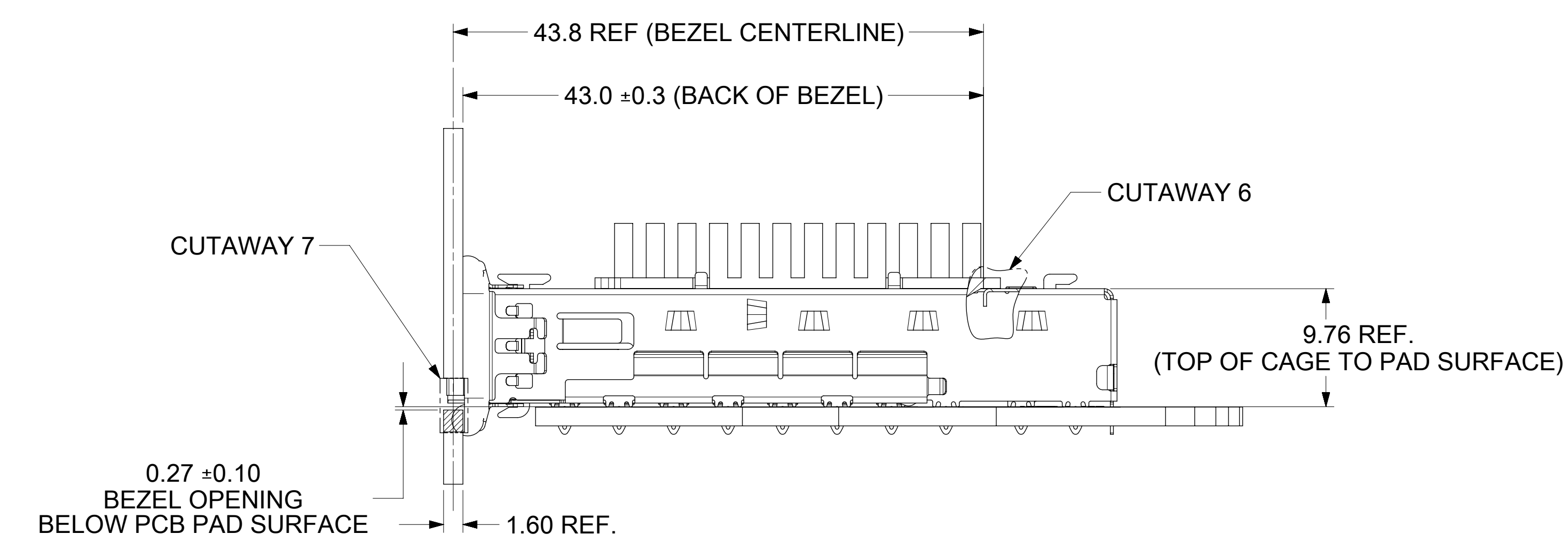

NOTES:
 1. PCB THICKNESS VARIATION MUST BE CONSIDERED WHEN DETERMINING BEZEL OPENING, SIZE AND LOCATION.

THIS DRAWING CONTAINS INFORMATION THAT IS PROPRIETARY TO MOLEX ELECTRONIC TECHNOLOGIES, LLC AND SHOULD NOT BE USED WITHOUT WRITTEN PERMISSION									
DIMENSION UNITS	SCALE	CURRENT REV DESC:							
mm	3:1								
GENERAL TOLERANCES (UNLESS SPECIFIED)		EC NO: 744377			QSFP+ 1X3 GANGED CAGE, GASKET TYPE W/ SUS INNER SPRING FINGER				
ANGULAR TOL	± 1.0°	DRWN: DKUMARG 2023/03/29			PRODUCT CUSTOMER DRAWING				
4 PLACES	±	CHK'D: AMRUTH 2023/03/30			DOCUMENT NUMBER				
3 PLACES	±	APPR: TKUMARKC 2023/03/31			747683506				
2 PLACES	± 0.15	INITIAL REVISION:			DOC TYPE				
1 PLACE	± 0.25	DRWN: CHETHH2 2022/05/25			PSD				
0 PLACES	±	APPR: SCHIEN 2022/07/07			AS Y				
DRAFT WHERE APPLICABLE MUST REMAIN WITHIN DIMENSIONS		THIRD ANGLE PROJECTION	DRAWING	SERIES	MATERIAL NUMBER			CUSTOMER	SHEET NUMBER
			D-SIZE	74768	SEE P/N TABLE				6 OF 7

DOCUMENT STATUS	P1	RELEASE DATE	2023/03/31	10:58:52
-----------------	----	--------------	------------	----------

REV	DATE	DESCRIPTION
A	2022/06/25	INITIAL RELEASE
A1	2023/03/29	UPDATED ALL THE VIEWS

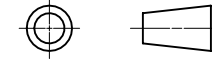
THIS DRAWING CONTAINS INFORMATION THAT IS PROPRIETARY TO MOLEX ELECTRONIC TECHNOLOGIES, LLC AND SHOULD NOT BE USED WITHOUT WRITTEN PERMISSION									
DIMENSION UNITS	SCALE	CURRENT REV DESC:				molex			
mm	1:1								
GENERAL TOLERANCES (UNLESS SPECIFIED)									
ANGULAR TOL	± 1.0°								
4 PLACES	±	EC NO: 744377							
3 PLACES	±	DRWN: DKUMARG 2023/03/29							
2 PLACES	± 0.15	CHK'D: AMRUTH 2023/03/30							
1 PLACE	± 0.25	APPR: TKUMARKC 2023/03/31							
0 PLACES	±	INITIAL REVISION:							
DRAFT WHERE APPLICABLE MUST REMAIN WITHIN DIMENSIONS		THIRD ANGLE PROJECTION		DRAWING	SERIES	MATERIAL NUMBER	CUSTOMER	SHEET NUMBER	
				D-SIZE	74768	747683506	SEE P/N TABLE	7 OF 7	

molex			
QSFP+ 1X3 GANGED CAGE, GASKET TYPE W/ SUS INNER SPRING FINGER			
PRODUCT CUSTOMER DRAWING			
DOCUMENT NUMBER	DOC TYPE	DOC PART	REVISION
747683506	PSD	ASY	A1

DOCUMENT STATUS	P1	RELEASE DATE	2023/03/31	10:58:52
-----------------	----	--------------	------------	----------