

# LM4663 Boomer® Audio Power Amplifier Series

## 2 Watt Stereo Class D Audio Power Amplifier with Stereo Headphone Amplifier

### General Description

The LM4663 is a fully integrated single supply, high efficiency Class D audio power amplifier solution. The LM4663 utilizes a continuous time delta-sigma modulation technique that lowers output noise and THD when compared to conventional pulse width modulators.

The LM4663 also features a stereo headphone amplifier that delivers 80mW into a 32Ω headset with less than 0.5% THD. The LM4663 has two stereo inputs that can be selected to drive either the headphone amplifier or the Class D amplifier. All amplifiers are protected with thermal shutdown.

In standby mode, the LM4663 draws an extremely low 2μA supply current. With a 4Ω load, the IC's efficiency for a 250mW power level is 69%, reaching 83% at a power level of 2W. The IC features click and pop reduction circuitry that minimizes audible popping during device turn-on and turn-off. The LM4663 is available in a 24-lead TSSOP package, ideal for portable and desktop computer applications.

### Key Specifications

- P<sub>O</sub> at THD+N = 1% 2.1W (typ)
- THD+N at 1kHz at 1 Watt into 4Ω (Power Amp) 0.2% (typ)

- Efficiency at 2 Watt into 4Ω 83% (typ)
- Efficiency at 250mW into 4Ω 69% (typ)
- Total quiescent power supply current 22mA (typ)
- Total shutdown power supply current 2μA (typ)
- THD+N 1kHz, 20mW, 32Ω (Headphone) 0.15% (typ)
- Single supply range 4.5V to 5.5V

### Features

- Delta-sigma modulator.
- Two stereo input selector.
- "Click and pop" suppression circuitry.
- Micropower shutdown mode.
- 24 lead TSSOP package (No heatsink required).
- Stereo headphone amplifier.

### Applications

- Portable computers
- Desktop computers
- Multimedia Monitors

### Block Diagram

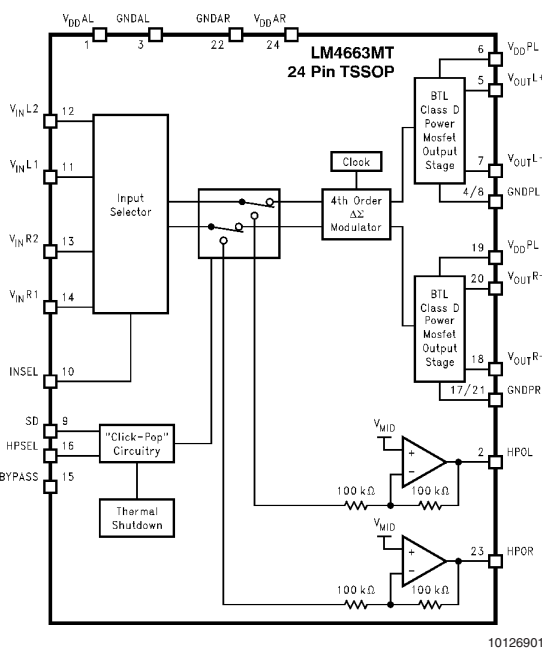

### Connection Diagram

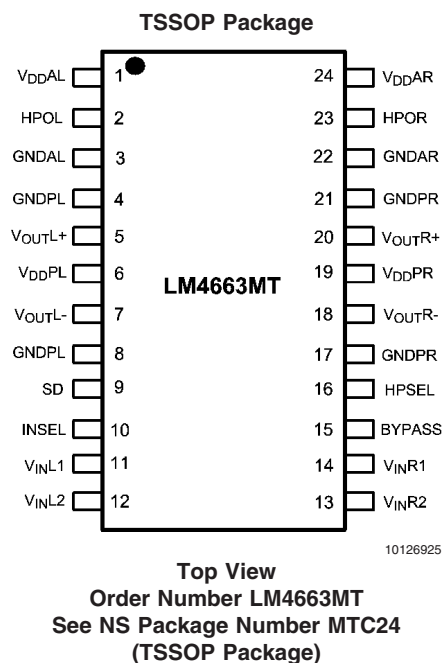

BOOMER™ is a trademark of National Semiconductor Corporation.

**Absolute Maximum Ratings** (Note 2)

If Military/Aerospace specified devices are required, please contact the National Semiconductor Sales Office/Distributors for availability and specifications.

Supply Voltage	6.0V
Input Voltage	-0.3V to $V_{DD} + 0.3V$
Power Dissipation (Note 3)	Internally Limited
Load Resistance	2.5Ω, min
ESD Susceptibility (Note 4)	2000V
Pins 5, 7, 18, 20	600V
ESD Susceptibility (Note 5)	200V
Pins 5, 7, 18, 20	50V
Junction Temperature (Note 6)	150°C
Storage Temperature	-65°C ≤ $T_A$ ≤ 150°C

Soldering Information

**Electrical Characteristics** (Notes 1, 2, 7)

The following specifications apply for  $V_{DD} = 5V$ ,  $R_L = 4Ω$ , LC filter values as shown in Figure 1, unless otherwise specified. Limits apply for  $T_A = 25°C$ .

Symbol	Parameter	Conditions	LM4663			Units
			Typical	Max	Min	
$V_S$	Operating Supply Voltage Range		5	5.5	4.5	V
$I_S$	Quiescent Power Supply Current, Class D Mode	$V_{IN} = 0V_{RMS}$ , $V_{HPSEL} = 0V$	22	35		mA
$I_S$	Quiescent Power Supply Current, Headphone Mode	$V_{IN} = 0V_{RMS}$ , $V_{HPSEL} = V_S$	5	10		mA
$I_{SD}$	Quiescent Power Supply Current, Shutdown Mode	$V_{SD} = 5V$	2			μA
$R_{IN}$	Input Resistance in Both Modes		20			kΩ
$V_{IH}$	Minimum High Level Input Voltage	Shutdown Pin & Input Select Pin			4.5	V
$V_{IL}$	Maximum Low Level Input Voltage	Shutdown Pin & Input Select Pin		0.5		V
$V_{IH}$	Minimum High Level Input Voltage	Headphone Select Pin			4.5	V
$V_{IL}$	Maximum Low Level Input Voltage	Headphone Select Pin		0.5		V
<b>Power Amplifiers</b>						
$P_{OR}$	Output Power, Per Channel	THD+N ≤ 1%, $f_{IN} = 1kHz$	2.1			W
$P_{D1}$	Power Dissipation	$P_O = 2W/Chan$ , $f_{IN} = 1kHz$	0.82			W
$P_{D2}$	Power Dissipation	$P_O = 1W/Chan$ , $f_{IN} = 1kHz$	0.49			W
$P_{D3}$	Power Dissipation	$P_O = .25W/Chan$ , $f_{IN} = 1kHz$	0.23			W
$E_{FF1}$	Efficiency	$P_O = 2W/Chan$ , $f_{IN} = 1kHz$	83			%
$E_{FF2}$	Efficiency	$P_O = 1W/Chan$ , $R_L = 8Ω$ , $f_{IN} = 1kHz$	85		80	%
$E_{FF3}$	Efficiency	$P_O = .25W/Chan$ , $f_{IN} = 1kHz$	69			%
THD+N	Harmonic Distortion + Noise	$P_O = 1W/Chan$ , $f_{IN} = 1kHz$	0.2			%
$V_{NOISE}$	Output Noise Voltage, RMS, A-Weighted	$R_{SOURCE} = 50Ω$ , $C_{IN} = 1μF$ , BW = 8Hz to 22kHz	200			μV
PSRR	Power Supply Rejection Ratio (Referred to Input)	200mV, 1kHz, $V_{IN} = 0$	44			dB
$A_V$	Voltage Gain	1kHz, $V_{IN} = 100mV$ , $R_L = 4Ω$	13			dB

**TSSOP Package**

Vapor Phase (60 sec.)	215°C
Infrared (15 sec.)	220°C

See AN-450 "Surface Mounting and their Effects on Product Reliability" for other methods of soldering surface mount devices.

**Operating Ratings** (Notes 1, 2)

Temperature Range	$T_{MIN} ≤ T_A ≤ T_{MAX}$	-40°C ≤ $T_A$ ≤ +85°C
Supply Voltage		4.5V ≤ $V_{DD}$ ≤ 5.5V
Thermal Resistance (TSSOP Package)		
$θ_{JA}$		80°C/W
$θ_{JC}$		20°C/W

## Electrical Characteristics (Notes 1, 2, 7) (Continued)

The following specifications apply for  $V_{DD} = 5V$ ,  $R_L = 4\Omega$ , LC filter values as shown in Figure 1, unless otherwise specified. Limits apply for  $T_A = 25^\circ C$ .

Symbol	Parameter	Conditions	LM4663			Units
			Typical	Max	Min	
$A_{VL}-A_{VR}$	Stereo Gain Tracking	1kHz, $V_{IN} = 100mV$ , $R_L = 4\Omega$	0.1			dB
<b>Headphone Amplifiers</b>						
$P_O$	Power Out Per Channel	THD+N $\leq 1\%$ , $R_L = 32\Omega$ , $f_{IN} = 1kHz$	80		60	mW
THD+N	Distortion + Noise	$P_O = 20mW$ , $R_L = 32\Omega$ , $f_{IN} = 1kHz$	0.15			%
$V_{NOISE}$	Output Noise Voltage, RMS	$R_{IN} = 50\Omega$ , $C_{IN} = 1\mu F$ , BW = 8Hz to 22kHz	30			$\mu V$
PSRR	Power Supply Rejection Ratio (Referred to Input)	200mV, 1kHz, $V_{IN} = 0$ , $R_L = 32\Omega$	44			dB
$A_V$	Voltage Gain	1kHz, $V_{IN} = 100mV$ , $R_L = 32\Omega$	5.5			dB
$A_{VL}-A_{VR}$	Stereo Gain Tracking	1kHz, $V_{IN} = 100mV$ , $R_L = 32\Omega$	0.1			dB

**Note 1:** All voltages are measured with respect to the ground pin, unless otherwise specified.

**Note 2:** "Absolute Maximum Ratings" indicate limits beyond which damage to the device may occur. "Operating Ratings" indicate conditions for which the device is functional, but do not guarantee specific performance limits. "Electrical Characteristics" state DC and AC electrical specifications under particular test conditions which guarantee specific performance limits. This assumes that the device is within the Operating Ratings. Specifications are not guaranteed for parameters where no limit is given, however, the typical value is a good indication of device performance.

**Note 3:** For operating at case temperatures above  $25^\circ C$ , the device must be derated based on a  $150^\circ C$  maximum junction temperature and a thermal resistance of  $\theta_{JA} = 80^\circ C/W$  (junction to ambient).

**Note 4:** Human body model, 100pF discharged through a 1.5k $\Omega$  resistor.

**Note 5:** Machine Model 220pF–240pF discharged through all pins.

**Note 6:** The operating junction temperature maximum is  $150^\circ C$ .

**Note 7:** Limits are guaranteed to National's AOQL (Average Outgoing Quality Level).

## Typical Performance Characteristics

Efficiency vs Output Power

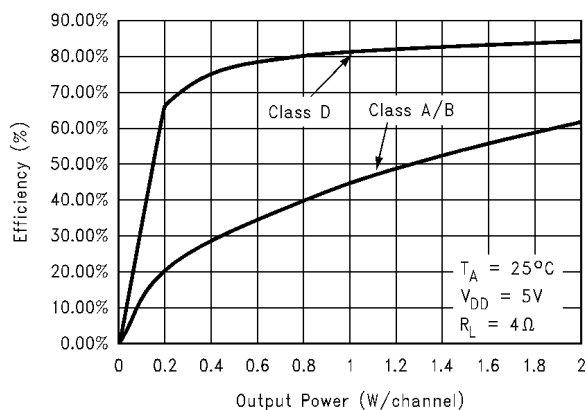

10126910

Power Dissipation vs Output Power

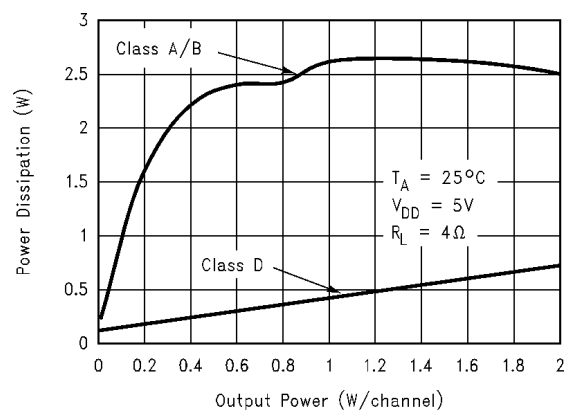

10126911

# Typical Performance Characteristics (Continued)

**Class D Amplifier  
In-Band Output Spectrum**

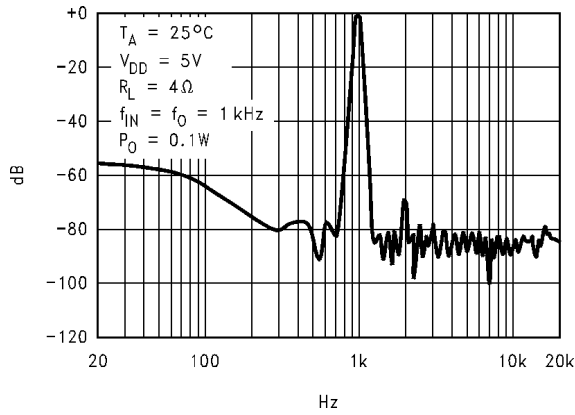

**Class D Amplifier  
In-Band Output Spectrum**

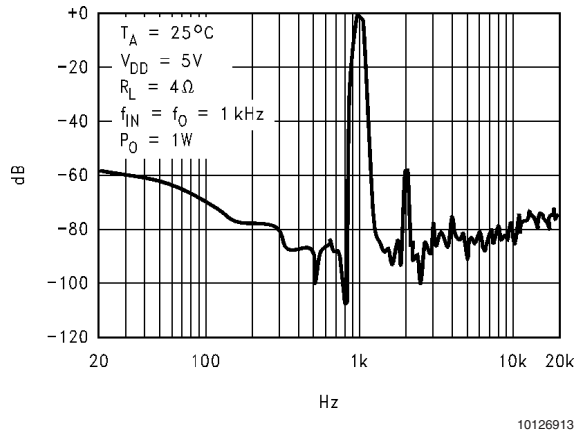

**Class D Amplifier  
THD + N vs Power vs Frequency**

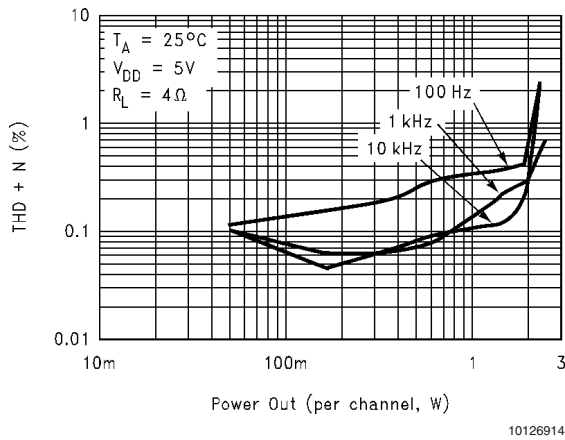

**Class D Amplifier  
THD + N vs Frequency vs Power**

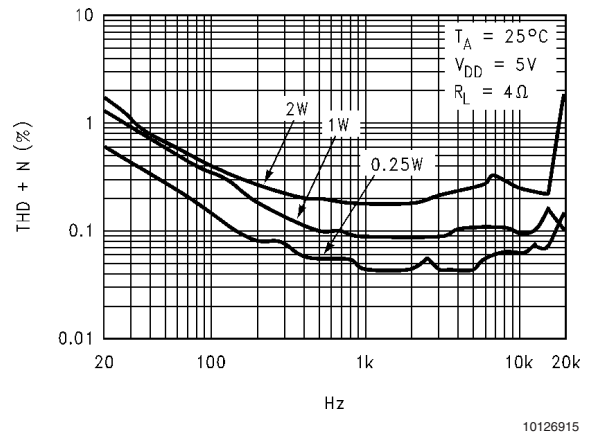

**Headphone THD + N vs Frequency vs Power**

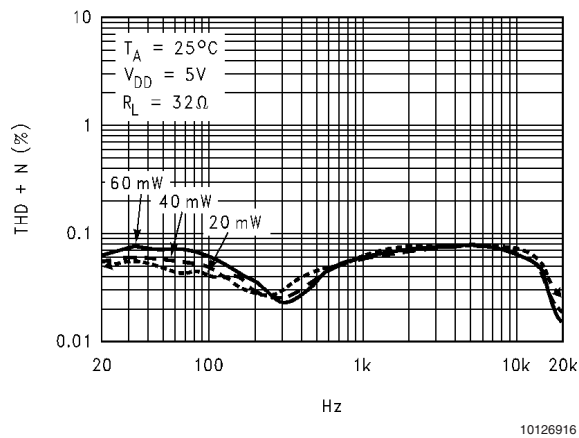

# Applications Information

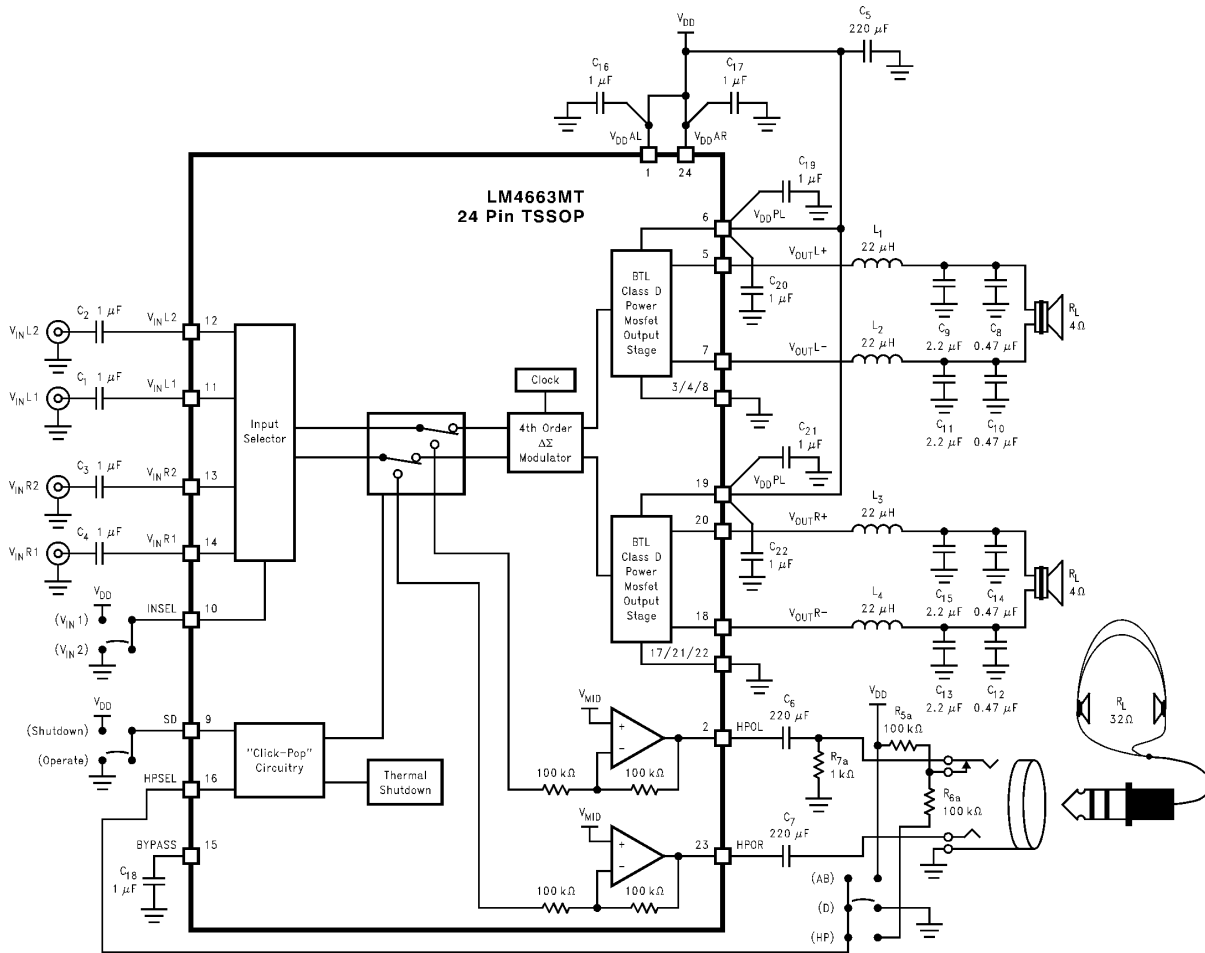

10126903

**FIGURE 1. Operating on a single 5V supply, this recommended application circuit is a complete solution with 2W Class D amplifiers that drive 4Ω speakers and 80mW amplifiers drive 32Ω headphones.**

## SUGGESTED APPLICATION CIRCUIT

The LM4663 achieves its specified performance using the recommended application circuit shown in Figure 1. The circuit provides full access to the stereo 2W/channel power amplifiers and the 80mW/channel stereo headphone amplifier. The HPSELECT (headphone select) input is controlled by a stereo mini-plug/jack with additional control contact. Other applications of this device may use external generated logic signals to control this function.

## CONTROL PINS

The LM4663 has three control pins: INSEL, SD, and HPSEL. The INSEL pin is used to select between the two stereo inputs,  $V_{IN1}$  and  $V_{IN2}$ . Connecting the INSEL pin to the positive supply selects  $V_{IN1}$ , whereas pulling it to ground selects  $V_{IN2}$ . Micropower shutdown operation is selected by pulling the SD to the positive supply. Applying the positive supply to the HPSEL pin selects the headphone amplifiers and grounding the HPSEL pin selects the Class D amplifiers. Table 1 is a summary of the function selected when applying ground or  $V_{DD}$  to the control pins.

**TABLE 1. Function selected when applying  $V_{DD}$  or GND to the INSEL, SD, and HPSEL control pins.**

Control Function	Pin	Apply GND	Apply $V_{DD}$
INSEL	10	$V_{IN2}$ L & R	$V_{IN1}$ L & R
SD	9	Full power operation	Micropower shutdown
HPSEL	16	Deactivate headphone amps and activate Class D amps	Deactivate Class D amps and activate headphone amps

## OUTPUT FILTERS

The LM4663's 2W power amplifiers use a Class D switching topology that requires a filter between the amplifier outputs and the load. The balanced, L-C filters shown in Figure 1 use component values recommended for a maximally flat magnitude in the pass-band and a cut-off frequency of 18kHz with a load impedance of 4Ω. We do not recommend omitting the filter because considerable out-of-band energy is

## Applications Information (Continued)

present in the Class D output waveform. This energy would be dissipated in the load impedance's resistive component, which diminishes efficiency.

### BYPASS PIN CAPACITOR

In order to achieve the largest unclipped output voltage swing, a DC reference voltage for the circuit is derived internally by a resistor divider from the power supply voltage. To reduce sensitivity to audio frequency variations on the reference voltage, a de-coupling capacitor is recommended between the BYPASS pin and the best available AC ground reference. This is typically the shield connection from the signal source. A poor choice is the power ground because considerable current flows from the LM4663 through pins 4, 8, 17, and 21 to the power supply return. This current is rich in harmonic frequencies related to the input audio frequency. These harmonics can easily couple into the signal path by sharing power ground conductors with the bypass capacitor connection. The result is increased THD.

### MINIMUM LOAD RESISTANCE

As specified in the Absolute Maximum Ratings, the minimum load resistance supported by the LM4663 at the output of the filters is 2.5 Ohms. Loads (usually loudspeakers) should be tested over the audio band to determine whether or not there are resonant points of diminished impedance less than this limit.

### OUTPUT FILTER COMPONENTS

Table 2 shows suggested standard values of the capacitor (C) and the inductor (L) used in Figure 1's output filter for 4Ω and 8Ω loads. The bandwidth for each case is typically 18kHz.

**TABLE 2. Output filter component values for different load resistance.**

Load Resistance (Ω)	Capacitor C (μF)	Inductor L (μH)
4	2	22
8	1	44

### SHORT CIRCUIT TOLERANCE

The LM4663, when used in the recommended application circuit, is tolerant of limited duration short circuit connections between the filtered positive and negative outputs. Shorts from either output to ground or supply voltage, or from the unfiltered outputs to any other low impedance node can result in permanent damage to the IC.

**TABLE 3. These are the functions selected by the jumpers on the recommended PC board.**

Jumper	Function
SD-L	<b>Shorting</b> selects normal operation. <b>SD-H Jumper is open.</b>
SD-H	<b>Shorting</b> activates shutdown: micropower operation. <b>SD-L Jumper is open.</b>
INSEL-L	<b>Shorting</b> selects stereo input 2. <b>INSEL-H Jumper is open.</b>
INSEL-H	<b>Shorting</b> selects stereo input 1. <b>INSEL-L Jumper is open.</b>

### START-UP CURRENT

The LM4663 exhibits abnormally high quiescent current drain when the supply voltage is below the specified operating range of 4.5 to 5.5V. It is, therefore, recommended that the IC be initially powered up in the shutdown mode (SD =  $V_{DD}$ ). Normal application of power from laboratory bench supplies is not usually a problem unless the current limit of the supply is set too low (<1A); however, some applications have a much lower current capability (such as USB applications). In these cases power must be applied with shutdown asserted and switched to the operating mode after power is present and settled. An external circuit that provides this condition automatically is given in Figure 2, and is recommended for those current-critical applications.

### PRINTED CIRCUIT BOARD LAYOUT

Figures 3 through 7 show the layout of a recommended four-layer PC board that is optimized for the LM4663 and associated external components. This layout emphasizes short connections between the power reservoir capacitors near the power amp outputs and their associated pins. Short connections reduce inductance and EMI radiation from the output switching currents. Also, the distance from the switching outputs to the filter inductors is similarly minimized to reduce radiated noise. Table 4 is the recommended circuit's bill-of-materials (BOM). Figure 8 is a photograph of the recommended four-layer PC board.

The board is designed for use with an external 5V supply, 4Ω speakers, and 32Ω headphones. Apply the supply voltage to the  $V_{DD}$  pad and ground to the GND pad. Connect the left channel speaker between the Lout+ and Lout- pads and the right channel speaker between the Rout+ and Rout- pads. Connect the left and right headphone speakers to the HPL and HPR pads, respectively. The board has two sets of HPL and HPR pads. Use the set found across the top edge for a headphone jack like that shown in Figure 1. The other set found along the right edge can be used for a three terminal headphone jack. Ensure that a speaker's + terminal is connected to an amplifier's + output. This preserves the phase relationship between the left and right channels.

The board accepts two stereo inputs. Apply channel 1's right and left input signals to the Rin1 and Lin1 pads, respectively. Apply channel 2's right and left input signals to the Rin2 and Lin2 pads, respectively.

The board's bottom edge has seven jumpers. From left to right, these jumpers select micropower shutdown, input channel, headphone amplifier, Class D amplifier, and headphone amplifier when plugging in headphones. Table 3 is a guide for selecting the various functions.

# Applications Information (Continued)

**TABLE 3. These are the functions selected by the jumpers on the recommended PC board. (Continued)**

Class AB	<b>Shorting</b> activates the headphone amplifier and deactivates the Class D amplifier. <b>Class D and HP jack jumpers are open</b>
Class D	<b>Shorting</b> activates the Class D amplifier and deactivates the headphone amplifier. <b>Class AB and HP jack jumpers are open</b>
HP Jack	<b>Shorting</b> allows the act of plugging in headphones to activate the headphone amplifier and deactivate the Class D amplifier. Removing headphones restores Class D amplifier operation and deactivates the headphone amplifier. <b>Class AB and Class D jumpers are open.</b> (Requires the use of a headphone jack like that shown in Figure 1.)

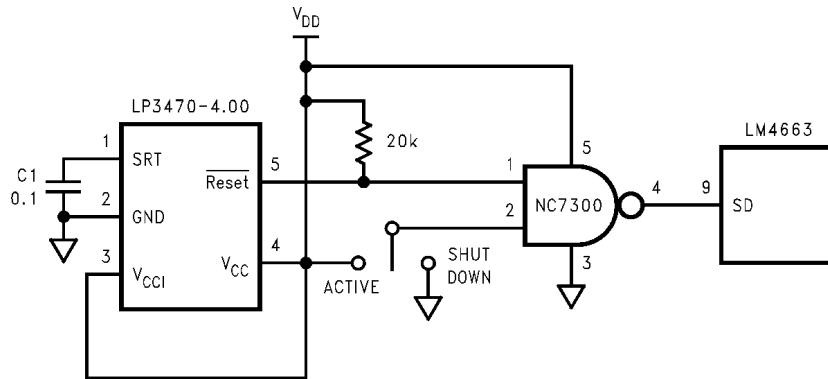

10126904

**FIGURE 2. At power-up, the LP3470 forces the LM4663 into shutdown, which prevents abnormal quiescent current flow through the amplifier. Once V<sub>CC</sub> rises above 4V and after a 200ms delay set by C1, normal amplifier operation is restored.**

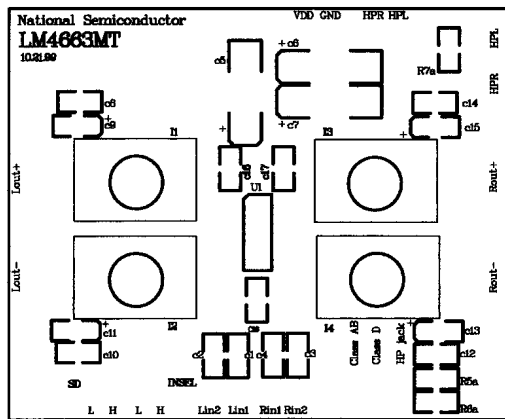

10126905

**FIGURE 3. Recommended PC board layout: Component side silkscreen**

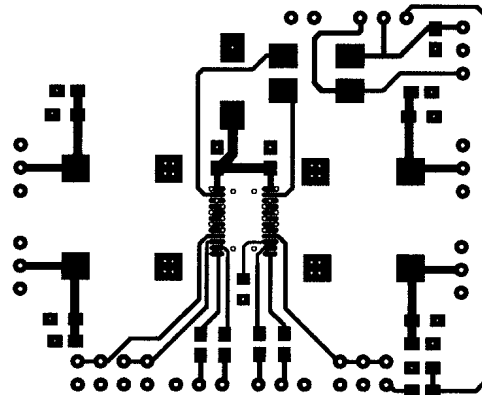

10126906

**FIGURE 4. Recommended PC board layout: Component side layout**

## Applications Information (Continued)

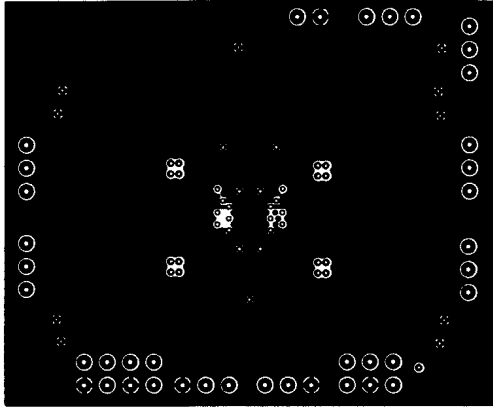

10126907

FIGURE 5. Recommended PC board layout: Inner Layer ground plane layout

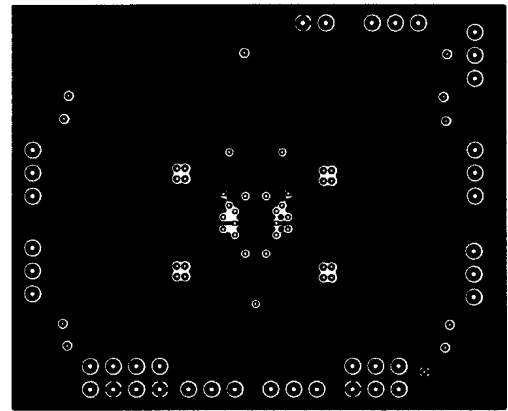

10126908

FIGURE 6. Recommended PC board layout: Inner Layer supply plane layout

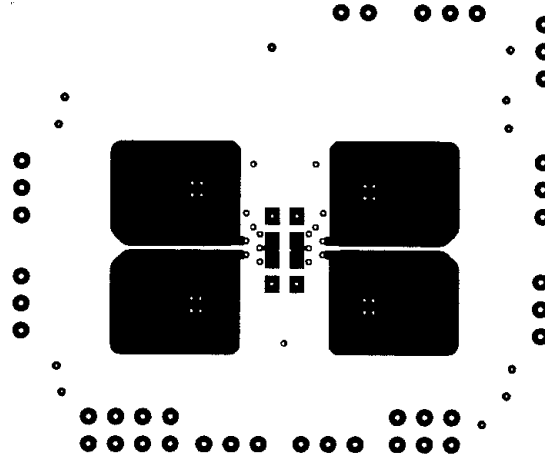

10126909

FIGURE 7. Recommended PC board layout: Bottom side layout

TABLE 4. Suggested PC Board Bill-of-Materials for recommended PC boards. (See Figures 1 and 3 through 7)

Component	Footprint	Type	Value	Size	Comment
C1-C4	0805	SMD/Top	1 $\mu$ F		
C5-C7	7243	SMD/Top	220 $\mu$ F	"D"	Tan./10V
C8,C10,C12,C14	0805	SMD/Top	.47 $\mu$ F		
C9,C11,C13,C15	3216	SMD/Top	2.2 $\mu$ F	"A"	Tan.
C16-C18	0805	SMD/Top	1 $\mu$ F		
C19-C22	0805	SMD/Bot	1 $\mu$ F		No Silkscreen
R5a,R6a	0805	SMD	100k		
R7a	0805	SMD	1k		
L1-L4	D03316P-223	SMD	22 $\mu$ H		Coilcraft: (847)639-6400 <a href="http://www.coilcraft.com">http://www.coilcraft.com</a>
U1	LM4663MT	TSSOP		24 Pin	National 2W Class D amplifier





## Revision History

Rev	Date	Description
1.1	04/11/06	Revised Connection Diagram

**Physical Dimensions** inches (millimeters) unless otherwise noted

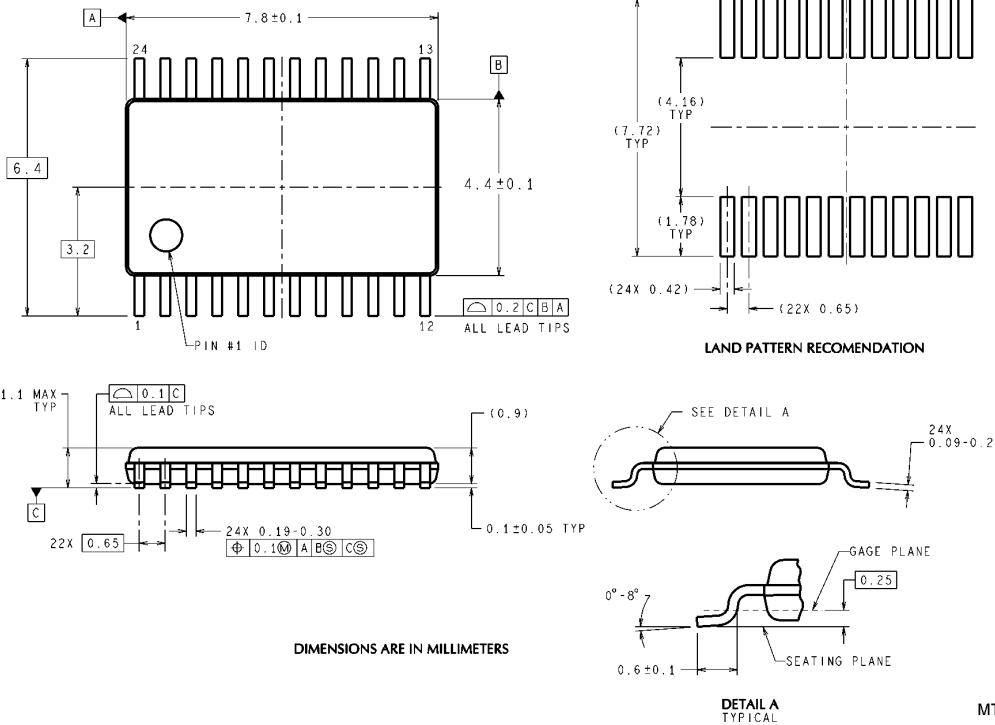

**Order Number LM4663MT**  
**NS Package Number MTC24**

MTC24 (Rev E)

National does not assume any responsibility for use of any circuitry described, no circuit patent licenses are implied and National reserves the right at any time without notice to change said circuitry and specifications.  
 For the most current product information visit us at [www.national.com](http://www.national.com).

**LIFE SUPPORT POLICY**

NATIONAL'S PRODUCTS ARE NOT AUTHORIZED FOR USE AS CRITICAL COMPONENTS IN LIFE SUPPORT DEVICES OR SYSTEMS WITHOUT THE EXPRESS WRITTEN APPROVAL OF THE PRESIDENT AND GENERAL COUNSEL OF NATIONAL SEMICONDUCTOR CORPORATION. As used herein:

1. Life support devices or systems are devices or systems which, (a) are intended for surgical implant into the body, or (b) support or sustain life, and whose failure to perform when properly used in accordance with instructions for use provided in the labeling, can be reasonably expected to result in a significant injury to the user.
2. A critical component is any component of a life support device or system whose failure to perform can be reasonably expected to cause the failure of the life support device or system, or to affect its safety or effectiveness.

**BANNED SUBSTANCE COMPLIANCE**

National Semiconductor manufactures products and uses packing materials that meet the provisions of the Customer Products Stewardship Specification (CSP-9-111C2) and the Banned Substances and Materials of Interest Specification (CSP-9-111S2) and contain no "Banned Substances" as defined in CSP-9-111S2.  
 Leadfree products are RoHS compliant.



**National Semiconductor**  
**Americas Customer Support Center**  
 Email: [new.feedback@nsc.com](mailto:new.feedback@nsc.com)  
 Tel: 1-800-272-9959

**National Semiconductor**  
**Europe Customer Support Center**  
 Fax: +49 (0) 180-530 85 86  
 Email: [europe.support@nsc.com](mailto:europe.support@nsc.com)  
 Deutsch Tel: +49 (0) 69 9508 6208  
 English Tel: +44 (0) 870 24 0 2171  
 Français Tel: +33 (0) 1 41 91 8790

**National Semiconductor**  
**Asia Pacific Customer Support Center**  
 Email: [ap.support@nsc.com](mailto:ap.support@nsc.com)

**National Semiconductor**  
**Japan Customer Support Center**  
 Fax: 81-3-5639-7507  
 Email: [jpn.feedback@nsc.com](mailto:jpn.feedback@nsc.com)  
 Tel: 81-3-5639-7560