

LOC	DIST	REVISIONS 変更					
J	-	P	LTR	DESCRIPTION	DATE	DWN	APVD
			O	RELEASED FJ00-0375-01	31-Jul-19	J.K	S.Y
			A	ECR-19-012054 Add applicable products	31JUL2019	S.N	J.K

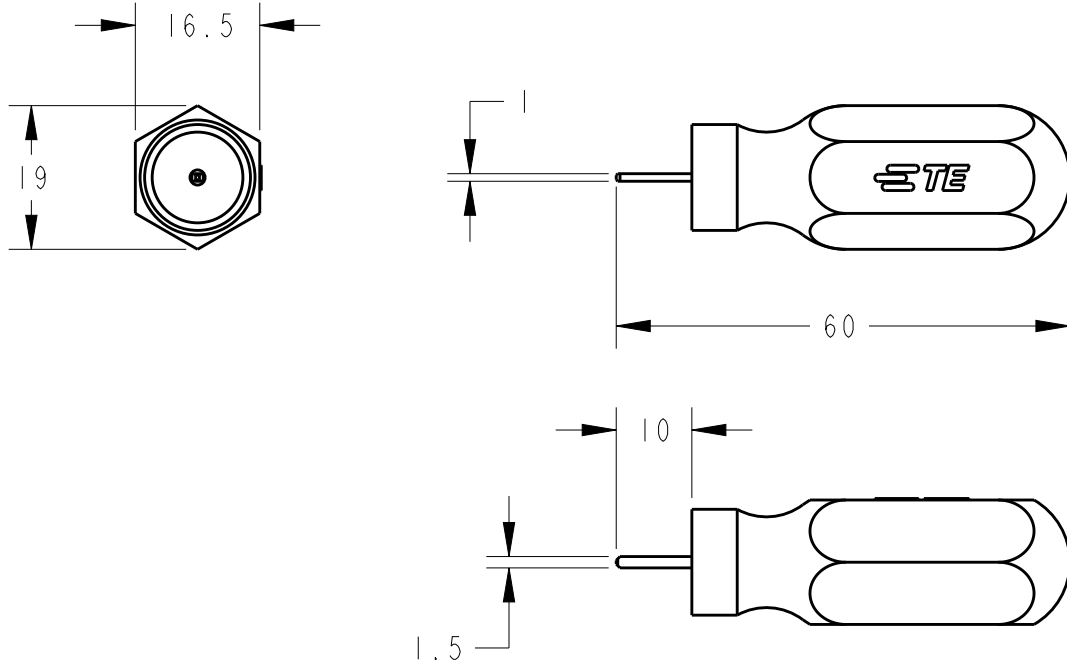

- 1 APPLICABLE PRODUCTS 適用製品
 TERMINAL (STRIP): 1123721-3 NEW MOTOR CONN EP CONTACT
 端子(連鎖状): 1123721-3 ニュー・モーター・コネクタ・EP・コンタクト
 HOUSING: 1473064-1
 ハウジング: 1473064-1
 REC KIT: 2345832-1, 2345832-2
 2345834-1, 2345834-2

- 2 INSTRUCTION SHEET NO: 411-5986
 取扱説明書: 411-5986

20

RELEASED FOR PUBLICATION

THIS DRAWING IS UNPUBLISHED.

BY TYCO ELECTRONICS CORPORATION. ALL RIGHTS RESERVED.
 © COPYRIGHT 20

DIMENSIONS: 単位: 耗 mm TOLERANCES UNLESS OTHERWISE SPECIFIED: 0 PLC ± 1 PLC ± 2 PLC ± 3 PLC ± 4 PLC ± ANGLES ±	DWN J.KOGA 01-Aug-19	MATERIAL 材料	FINISH 仕上			
	CHK J.KOGA 01-Aug-19	 TE Connectivity				
	APVD S.YABE 01-Aug-19					
	PRODUCT SPEC 製品規格 -	NAME 名称 EXT-TOOL FOR NEW MOTOR CONN ニュー・モーター・コネクタ・EP・コンタクト引き抜き工具				
APPLICATION SPEC 取付適用規格 -	SIZE A 4	CAGE CODE 00779	DRAWING NO 番号 C=1463329-1	RESTRICTED TO -		
WEIGHT -	CUSTOMER DRAWING			SCALE 尺度 :	SHEET OF	REV A