

THIS DRAWING IS UNPUBLISHED. RELEASED FOR PUBLICATION, 19 .  
 © COPYRIGHT 19 BY AMP INCORPORATED. ALL RIGHTS RESERVED.

LOC	DIST	REVISIONS			
P	LTR	DESCRIPTION	DATE	DWN	APVD
AJ	16	F	REDWN AND REV PER EC 0220-0720-95	15FEB96	MEC FPM
		G	REVISED PER 0503-0155-96	12-6-96	JG FM

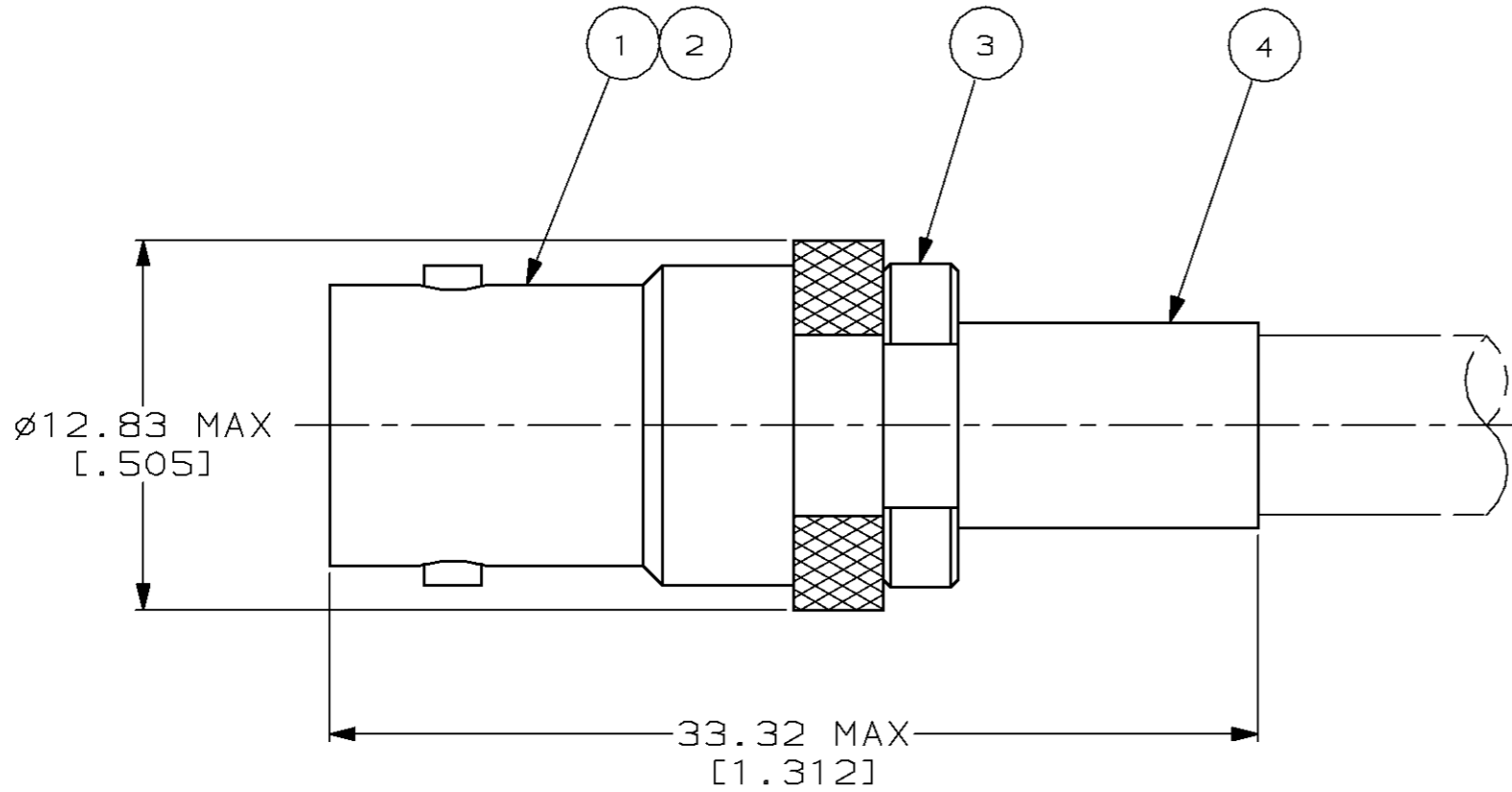

1. USE INSTRUCTION SHEET 1799-2
2. USE CRIMP TOOL 69141-1 WITH CABLE RG-59/U, 59A/U, 59B/U, 62/U, 62A/U, 62B/U, 124/U, 140/U AND 210/U

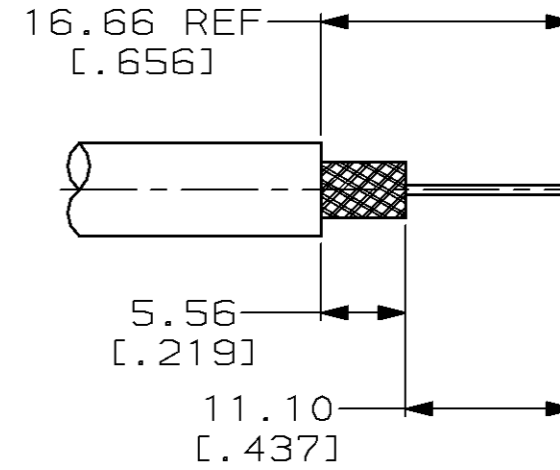

RECOMMENDED STRIP LENGTH  
SCALE 2:1

OBSOLETE	-	-	-	-	2-329063-2
2	329041	50793-2	2-329106-1	329061	2-329063-1
OBSOLETE	-	-	-	-	329063
4	FERRULE QTY=1	3	CRIMP END ASSEMBLY QTY=1	2	GASKET QTY=1
				1	JACK ASSEMBLY QTY=1
					PART NUMBER

THIS DRAWING IS A CONTROLLED DOCUMENT.		DWN MICHAEL E. COWHER 06FEB96	<b>AMP</b> AMP Incorporated Harrisburg, PA 17105-3608
		CHK FRANK P. MORANA 15FEB96	
DIMENSIONS: mm [INCHES]		APVD FRANK P. MORANA 15FEB96	NAME
TOLERANCES UNLESS OTHERWISE SPECIFIED:		PRODUCT SPEC	JACK, BNC
0 PLC ±-		APPLICATION SPEC	SIZE
1 PLC ±-		WEIGHT	CAGE CODE
2 PLC ±0.41 [.016]		CUSTOMER DRAWING	DRAWING NO
3 PLC ±-			A3 00779 C-329063
4 PLC ±-			SCALE 4:1
ANGLES ±-			SHEET 1 OF 1
MATERIAL -			REV G
FINISH -			