

© 1964 BY AMP INCORPORATED. ALL RIGHTS RESERVED. AMP PRODUCTS COVERED BY PATENTS AND/OR PATENTS PENDING. APPROVED PER GOVT CONTRACT NO.

REVISIONS				
SYM	ZONE	DESCRIPTION	DATE	APPROVAL
O		RELEASED WAS M5001-679	7/1/64	KY DSH
A		REVISED W-276	5-27-65	M.S./D.H.
B		REMOVE PROPOSED DESIGN STAMP W-530	7-23-65	M.S. RM
C		REVISED Y-68	1-18-66	M.S. J.H.
D		ADDED "A" DIMEN & -2 ECN A-881	11/3/70	MD SJS
D1		REV. PER ECN D-644	8 9-17-75	JK
E		REV PER ECO-05-001412	AA 05/05	DR
F		REV PER ECO-05-005359	11/65	PY/DE
G		ECO-09-002648	PY 5-09	DE
H		REV PER ECO 19-007987	CT 5-23-19	PD

SUPERSEDED BY 5-202567-1 202567-1 1. AS SHOWN.
 2. "A" DIMENSION = .891

OBSOLETE 202567-2 1. SAME AS -1 EXCEPT:
 2. "A" DIMENSION = 1.266

5-202567-1 1. SAME AS -1 EXCEPT:
 2. PLATED ELECTROLESS NICKEL PER SAE-AMS-C.26074
 .000400-.000800 THK (NO INTENTIONAL ADDITIONS
 OF LEAD OR CHROMIUM PER AFE STD 230-700).
 3. "A" DIMENSION = .891

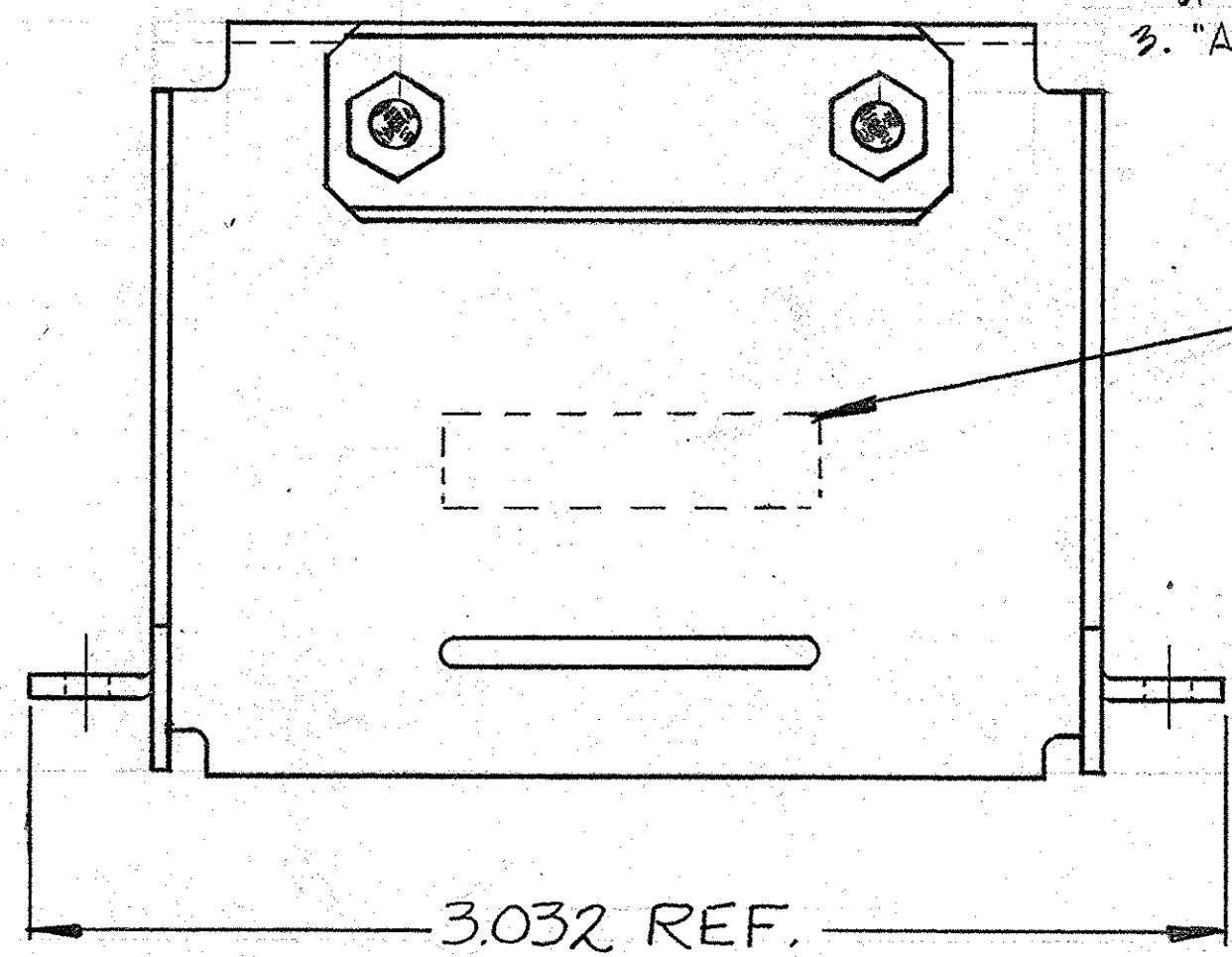
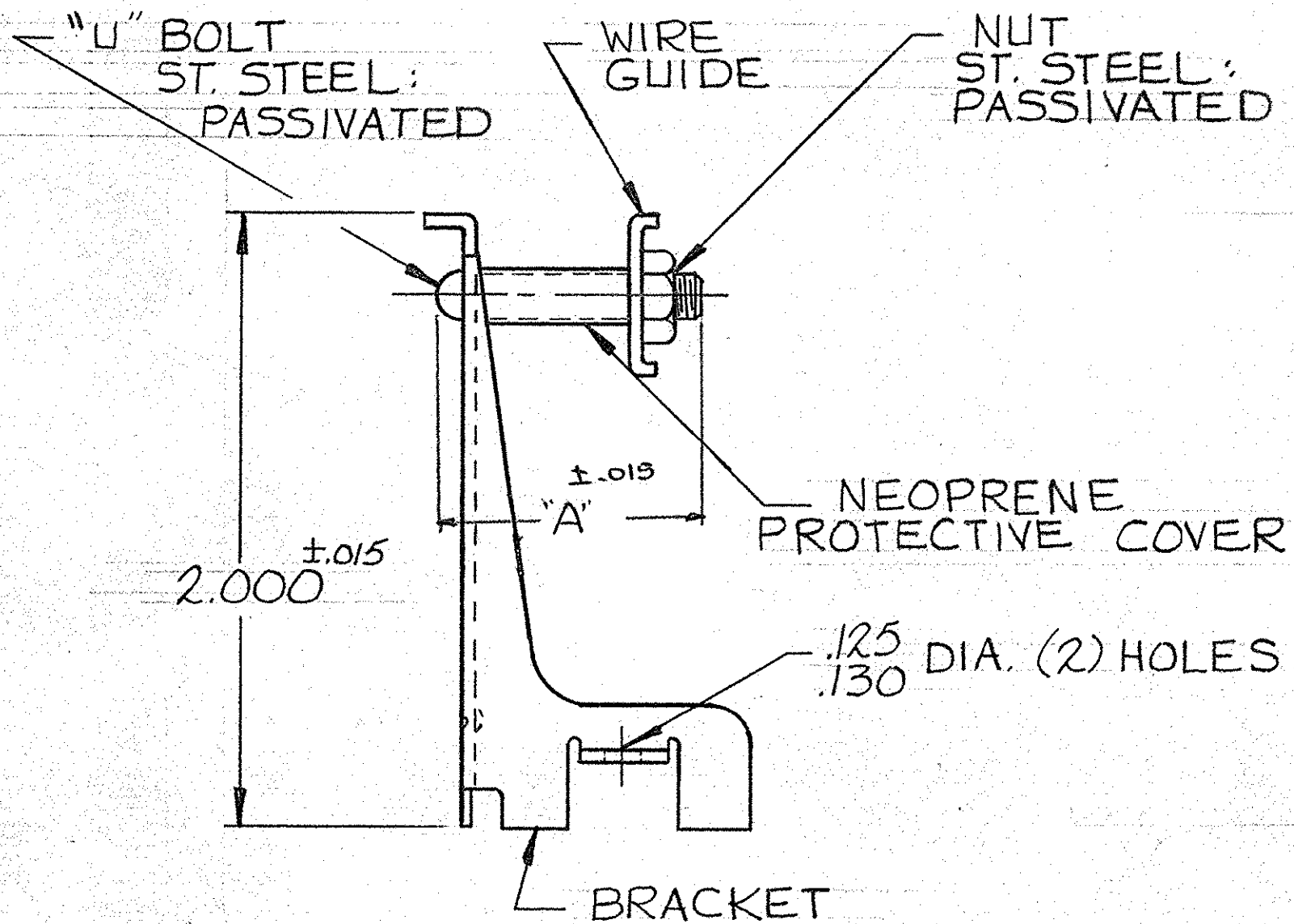

MARK "AMP" & ASS'Y. NO. & DATE CODE IN THIS AREA ON OPPOSITE SIDE,

NOTE:
 © 1. ZINC PLATE PER ASTM-B-633 CLASS 3 TYPE II. COLORLESS SUPPLEMENTARY CHROMATE.

AMP INFO		NOMENCLATURE OR DESCRIPTION		PART OR IDENTIFYING NO.	
LOC	PRINT DIST	R 391 E		LIST OF MATERIALS OR PARTS LIST	
UNLESS OTHERWISE SPECIFIED DIMENSIONS ARE IN INCHES TOLERANCES ON FRACTIONS DECIMALS ANGLES ± .005 ±			SIGNATURE		DATE
MATERIAL C. R. STEEL			DR K. Jones		6/2/64
HEAT TREAT			CHK J.S. Heide		7/23/64
FINISH SEE NOTE 1			DSGN ENGR J. Williams		7-22-64
			OPER CCurtis		7/22/64
			DSGN APPD		CODE IDENT NO 00779
			OTHER APPD		SIZE C
					NUMBER 202567
					REV H
			SCALE 2-1		WT CALC ACTUAL SHEET