

THIS DRAWING IS UNPUBLISHED. RELEASED FOR PUBLICATION 20
 © COPYRIGHT 20 BY - ALL RIGHTS RESERVED.

CONFIDENTIAL

REVISIONS					
P	LTR	DESCRIPTION	DATE	DWN	APVD
AA		RELEASED PER CRN24071	21APR2016	LS	KA
AB		RELEASED PER CRN24444	10FEB2017	DCB	KA
AC		RELEASED PER CRN25370	04FEB2019	LS	RM

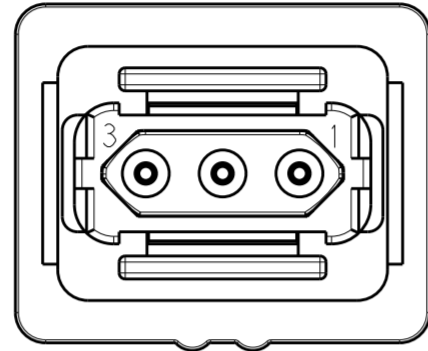
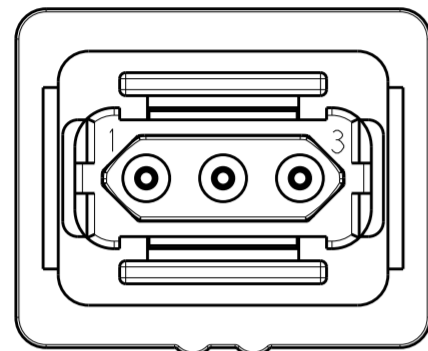
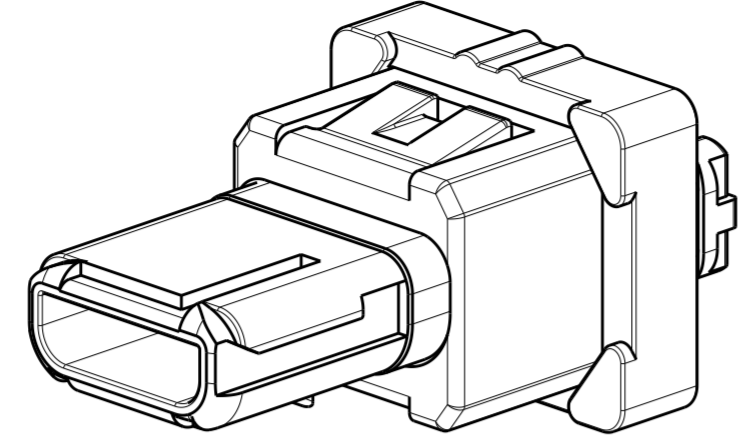
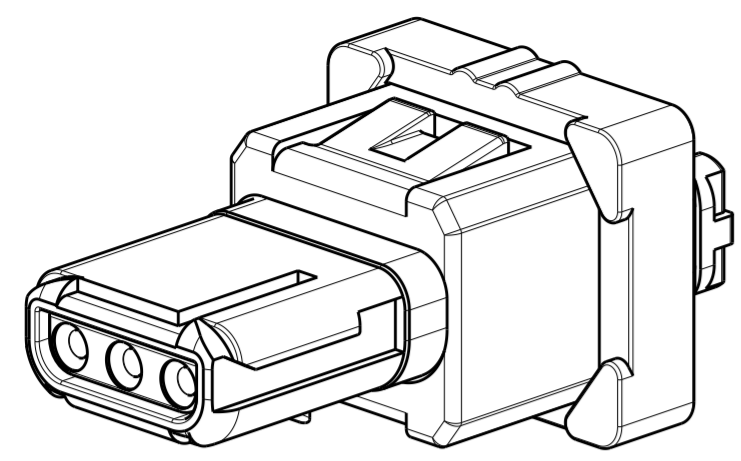

SOCKET/FEMALE CONTACT CAVITY IDENTIFICATION ON REAR

PIN/MALE CONTACT CAVITY IDENTIFICATION ON REAR

KEYWAY TABLE	
ORIENTATION	COLOR
N	BLACK
A	DARK RED
B	DARK BLUE
C	DARK GREEN
D	YELLOW

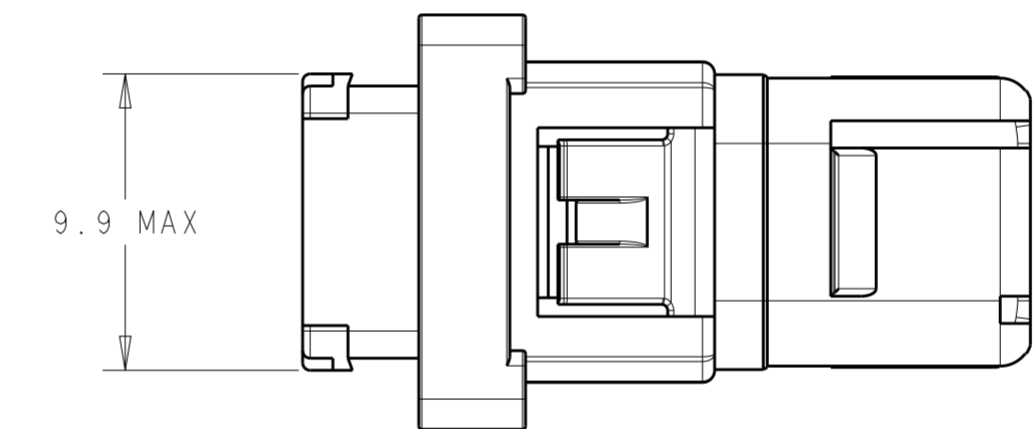
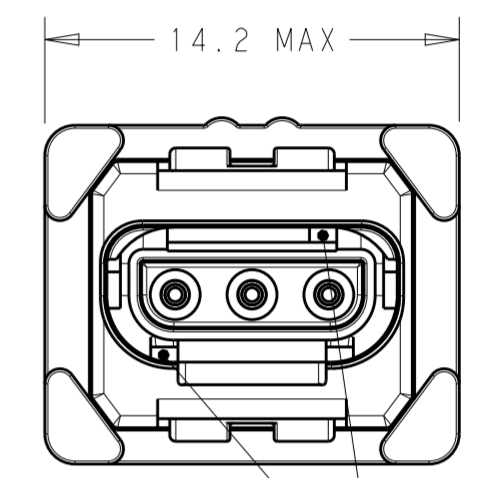
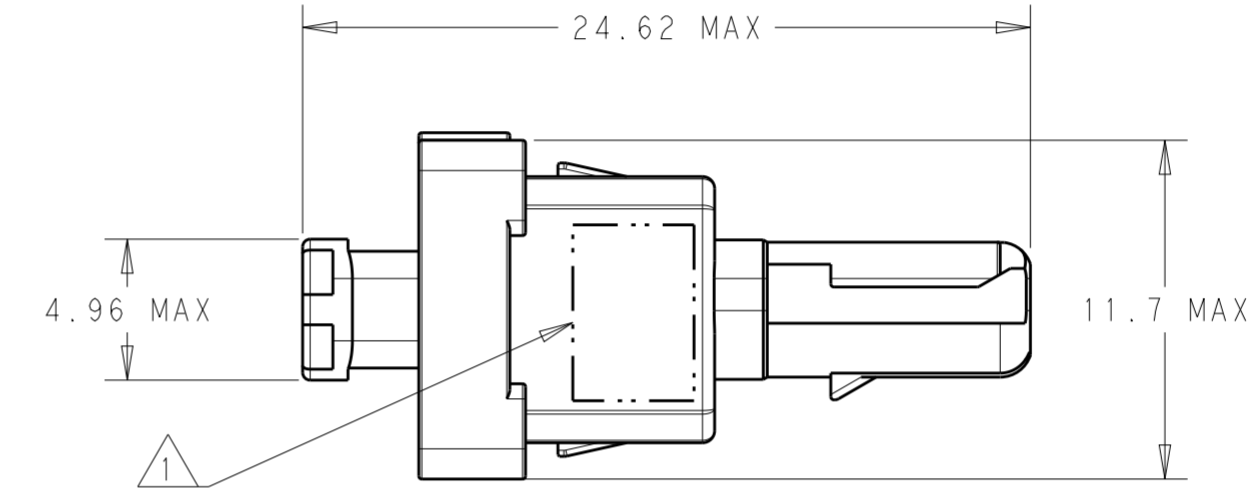

ORIENTATION KEYS ("N" SHOWN)

1. MARKED WITH DEUTSCH PART NO, DEUTSCH (HASTINGS) CAGE CODE AND DATE CODE ON EITHER SIDE.

PART NUMBER EXAMPLE: D369 - A 3 3 - N S 1

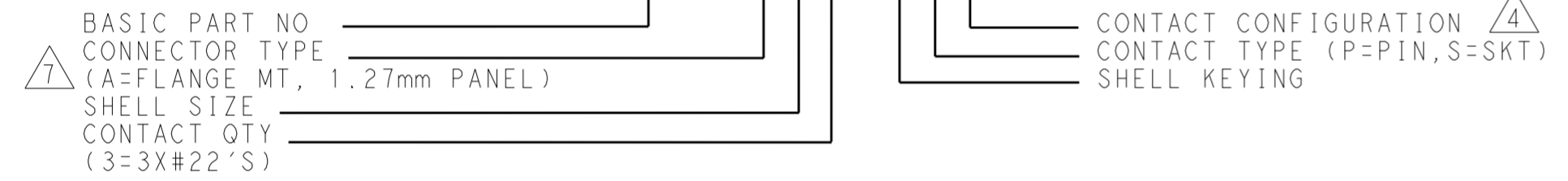

- 2. PERFORMANCE: TEMPERATURE RANGE: -55°C TO +175°C. INSULATION RESISTANCE: >5000MΩ. DIELECTRIC WITHSTAND: 1500VRMS, <2mA. SEALING: 15KM(50000FT) ALTITUDE/IP67 DURABILITY: 500 MATING CYCLES MIN. FLUID RESISTANCE: I.A.W. EN2591-315. FLAMMABILITY, SMOKE AND TOXICITY: I.A.W. FAR 25.853 APPENDIX F.
- 3. INSERTION/EXTRACTION TOOL (M81969/14-01 OR EQUIVALENT) SUPPLIED SEPARATELY.

CONTACT CONFIGURATION	CONTACT DESCRIPTION	CONTACT P/N (OR EQUIVALENT)		CRIMP POSITIONER		CRIMP TOOL	WIRE ACCOMMODATION	CURRENT RATING
		PIN	SOCKET	PIN	SOCKET			
0		NO CONTACTS SUPPLIED						
1	CRIMP, COPPER WIRE	38941-22	38946-22	M22520/2-09	M22520/2-06	M22520/2-01	22-28 AWG	5A (22 AWG)
2	CRIMP, ALUMINUM WIRE	200-1042-22	200-1142-22	KAL2		ALNP 22-A	22 AWG	5A
3	CRIMP, COPPER WIRE (ENLARGED WIRE)	182-0860-22	182-0862-22	M22520/2-09	M22520/2-06	M22520/2-01	20-24 AWG	5A (20 AWG)

5. MATERIALS: SEALS & PANEL GASKET: SILICONE/FLUROSILICONE BLEND RUBBER PER AMS-R-25988 TYPE II, CLASS I, GRADE 40. BODY/INSERT COMPONENTS: POLYETHERIMIDE, 10% GLASS FILLED PER ASTM D 5205 OR POLYETHERETHERKETONE 450G.

6. MAXIMUM WEIGHT (WITHOUT CONTACTS): 1.7g (SKT INSERT), 1.6g (PIN INSERT).

7. RECOMMENDED PANEL THICKNESSES LISTED IN TABLE BELOW FOR REFERENCE ONLY. REFER TO INSTRUCTION SHEET 408-32194 FOR RECOMMENDED PANEL CUT-OUT DIMENSIONS.

GASKET CONFIGURATION	NUMBER OF MARKS	RECOMMENED PANEL THICKNESS	GASKET PART NUMBER
A*	2	1.27	612154-3-A
B	3	1.60	612154-3-B
C*	4	2.03	612154-3-C

* - NOT TOOLED, CONSULT TE.

8. FILLER PLUGS AVAILABLE FOR CONTACT CAVITIES. TE PART NUMBER: 600300-22 MIL-SPEC: MS27488-22-2

SHELL COLOR IS KEYING DEPENDENT (SEE TABLE)

GASKET IDENTIFICATION MARKS ("A" SHOWN)

ACCESSORY OR BOOT MOUNTING FEATURE

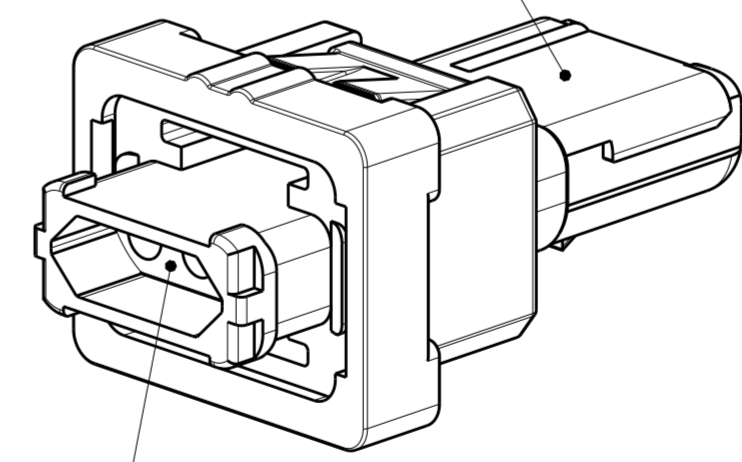

REAR WIRE SEAL

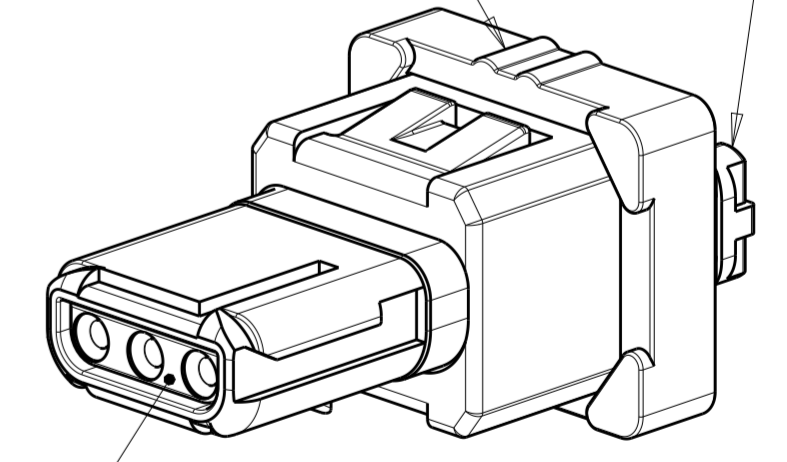

INSERT (SOCKET TYPE "S" SHOWN)

THIS DRAWING IS A CONTROLLED DOCUMENT.		DWN L.SIPE 10NOV2014	STE TE Connectivity	
		CHK K. ANNIS 02JUN2015		
DIMENSIONS: mm		TOLERANCES UNLESS OTHERWISE SPECIFIED:		NAME D369 PANEL MOUNT RECEPTACLE, SHELL SIZE 3, 3 WAY
0 PLC ±		1 PLC ±		PRODUCT SPEC -
1 PLC ±		2 PLC ±		APPLICATION SPEC -
2 PLC ±		3 PLC ±		WEIGHT 6.1
3 PLC ±		4 PLC ±		SCALE 4:1
4 PLC ±		ANGLES ±		SHEET 1 OF 1
MATERIAL -		FINISH -		RESTRICTED TO -
-		-		DRAWING NO C-612015-3-ENV
-		-		REV AC