

REVISIONS				
P.	LTN	DESCRIPTION	DATE	DMN APVD
J		REVISED PER ECR-14-016951	11FEB2015	J.T W.H

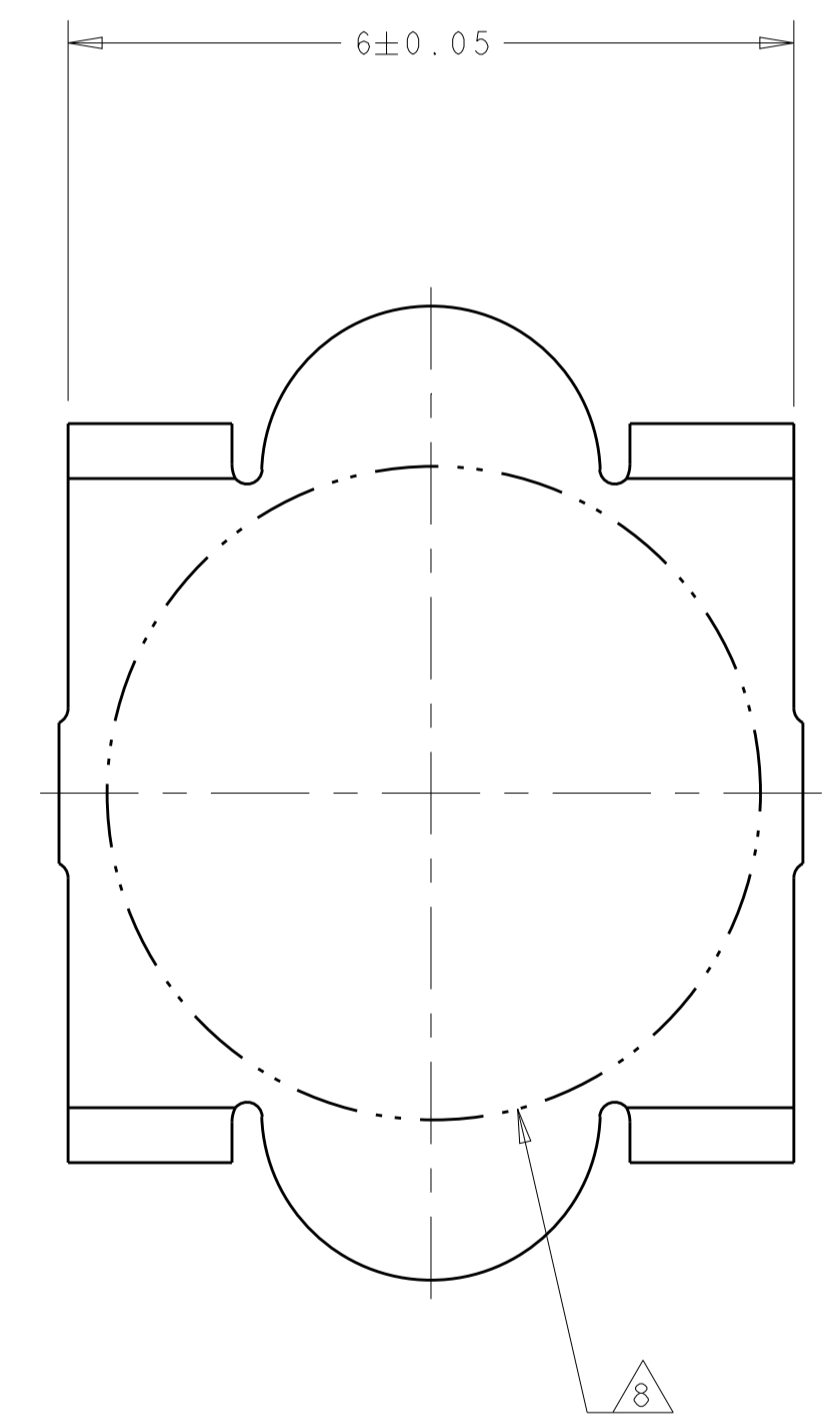

VACUUM COVER

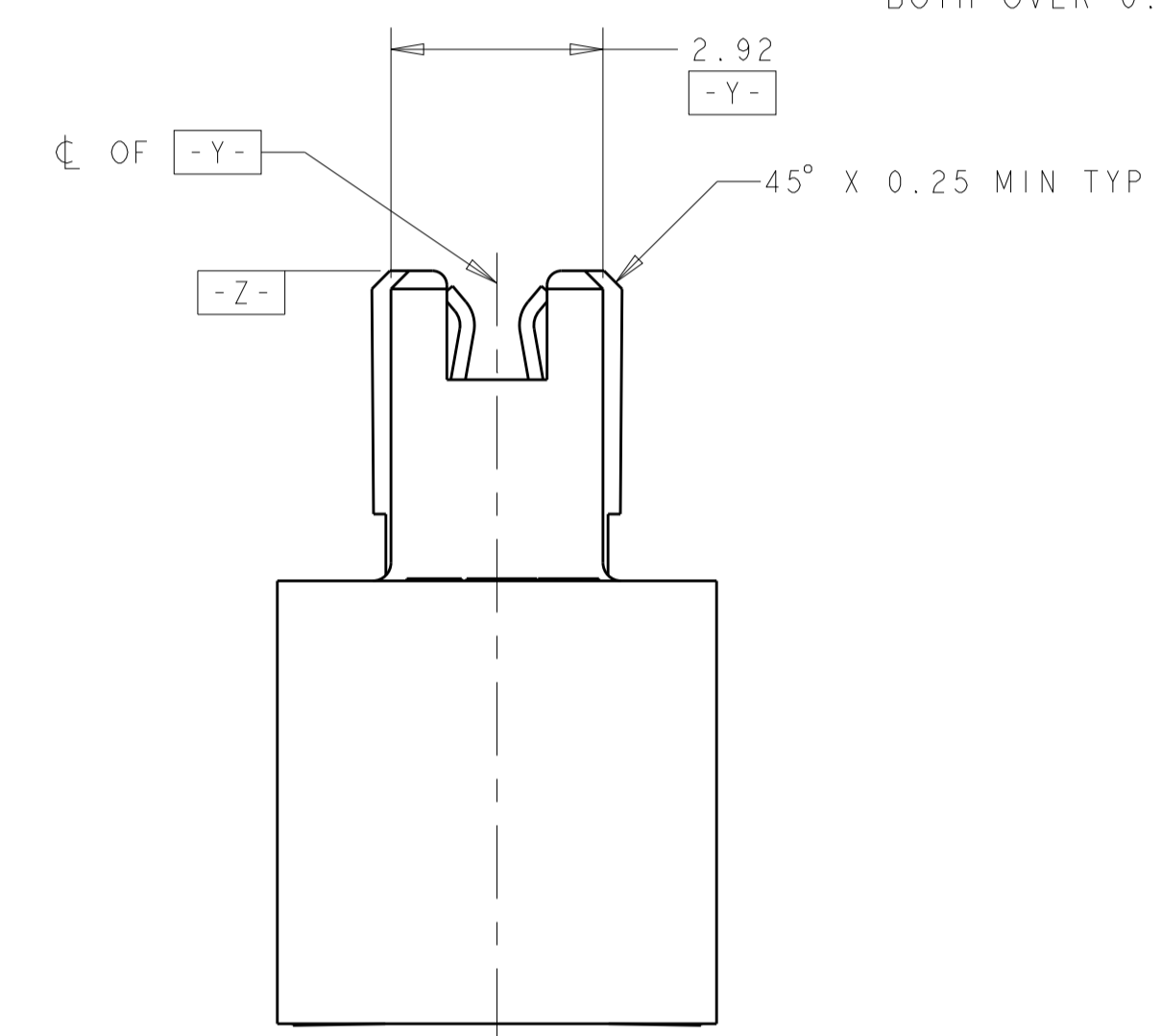
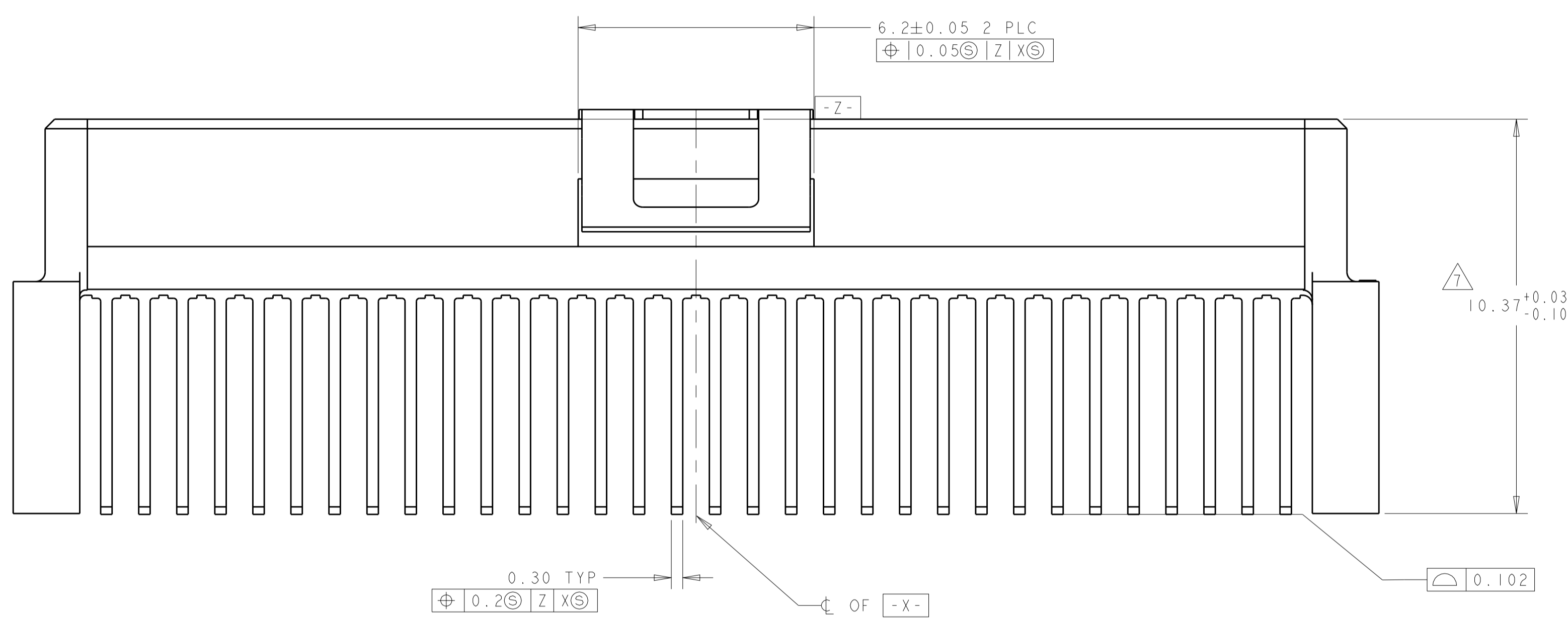
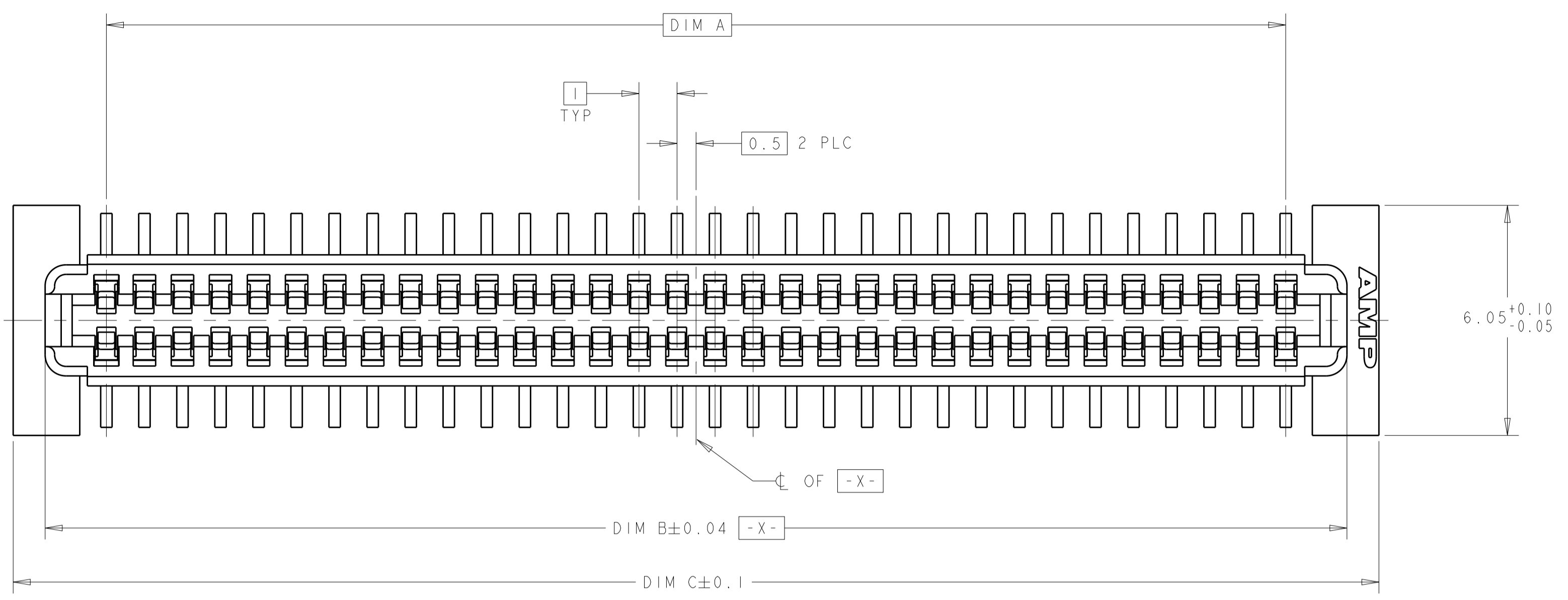
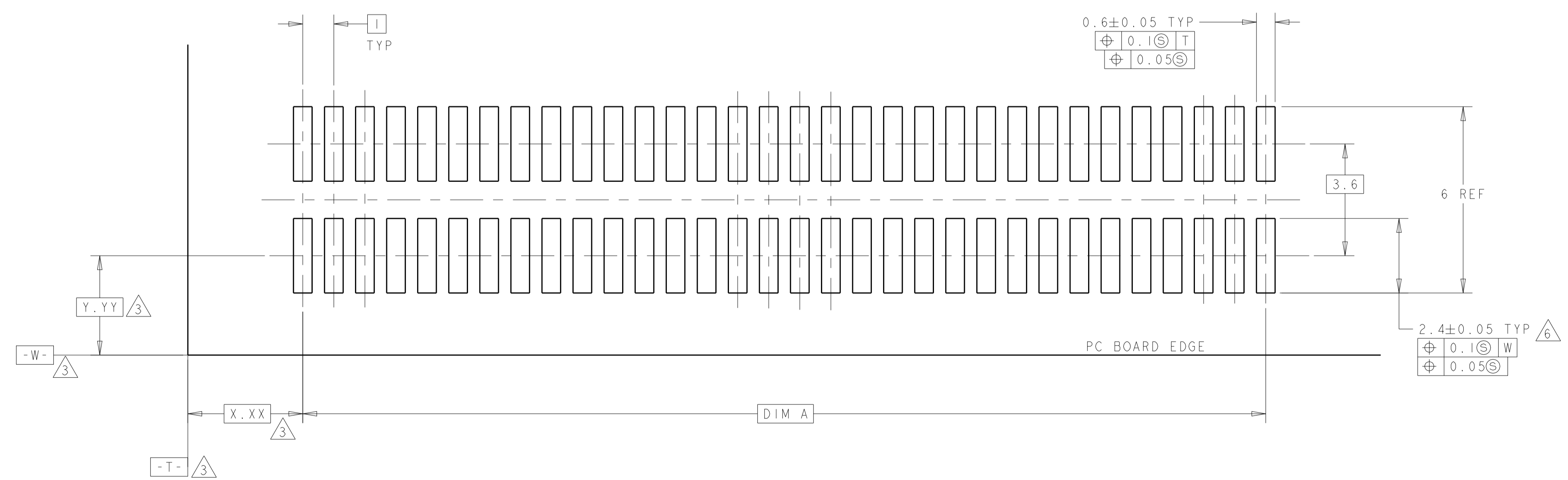

RECOMMENDED PC BOARD LAYOUT

- 1. HOUSING MATERIAL: HIGH TEMPERATURE THERMOPLASTIC, COLOR: BLACK. CONTACT MATERIAL: PHOSPHOR BRONZE.
- 2. CONTACT FINISH: NICKEL UNDERPLATE ALL OVER, MATING SURFACES PLATED TO MEET PLI PERFORMANCE REQUIREMENTS OF INDUSTRY SPECIFICATION EIA-700AAAB, SOLDER TAILS PLATED TIN-LEAD.
- 3. DATUM LOCATIONS AND BASIC DIMENSIONS TO BE ESTABLISHED BY THE CUSTOMER. CONSULT AMP ENGINEERING WHEN PLACING MULTIPLE CONNECTORS ON A PC BOARD.
- 4. PACKAGED IN TAPE ON REEL PER EIA-481.
- 5. VACUUM COVER DESIGNED FOR 4mm DIA. NOZZLE. COVER TO BE REMOVED AFTER SOLDERING. VACUUM COVER OMITTED FROM SOME VIEWS FOR DIMENSIONAL CLARITY.
- 6. SHORTER SOLDER LANDS MAY BE USED PER EIA 700AAAB, HOWEVER 2.4 LENGTH ASSURES OPTIMUM SOLDER FILLET REGARDLESS OF MANUFACTURER OF CONNECTOR.
- 7. REFERRED TO AS DIM H = 10.30 ± 0.1 IN EIA 700AAAB SPECIFICATION.
- 8. 5.5 MIN DIAMETER TARGET AREA FOR VACUUM PICK-UP.
- 9. CONTACT FINISH: 0.002 MINIMUM BRIGHT TIN-LEAD (93-7) ON SOLDER AREA, 0.00127 MINIMUM GOLD ON MATING AREA, BOTH OVER 0.00127 MINIMUM NICKEL ON ENTIRE CONTACT.

FINISH	DIM C	DIM B	DIM A	MATING CONNECTOR	STACK HGTS	POS	PART NO
9	45.9	44.22	41	120534-2	15	84	1-120531-2
9	45.9	44.22	41	120533-2	14	84	1-120531-2
9	35.9	34.22	31	120534-1	15	64	1-120531-1
9	35.9	34.22	31	120533-1	14	64	1-120531-1
2	45.9	44.22	41	120534-2	15	84	120531-2
2	45.9	44.22	41	120533-2	14	84	120531-2
2	35.9	34.22	31	120534-1	15	64	120531-1
2	35.9	34.22	31	120533-1	14	64	120531-1

THIS DRAWING IS A CONTROLLED DOCUMENT. DMN J. REED 27/17/97
CHK L. VO 27/17/97

DIMENSIONS: mm
TOLERANCES UNLESS OTHERWISE SPECIFIED:
0 PLC ±
1 PLC ±0.03
2 PLC ±0.03
3 PLC ±0.03
4 PLC ±
ANGLES 40°-30°
FINISH SEE TABLE

PRODUCT SPEC 502-1079
APPLICATION SPEC 114-25045
WEIGHT
CUSTOMER DRAWING

SCALE 10:1 SHEET 1 OF 1 REV J

STE TE Connectivity
RCPT ASSY, W/COVER, 1.0mm FH CONNECTOR (IEEE1386)
SIZE A1 CAGE CODE DRAWING NO. 120531