

DATE	REV	ECN	APP'D. BY
1-13-15	B3	10187	TRM
3-8-16	B4	10593	TRM

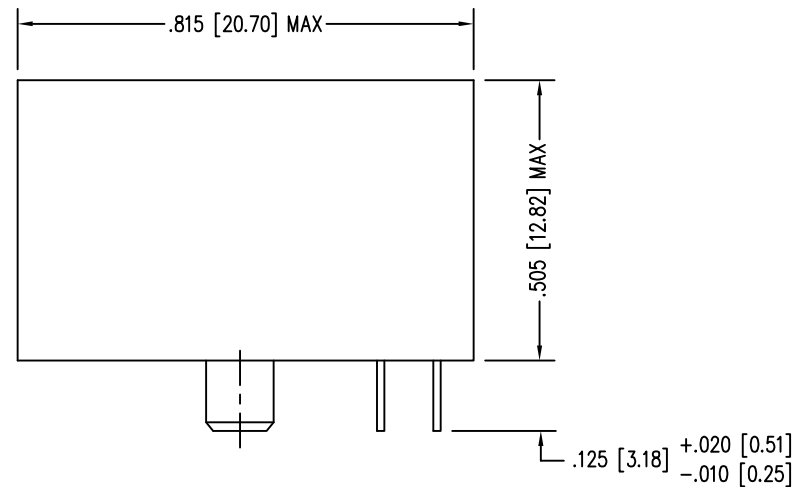

B

B

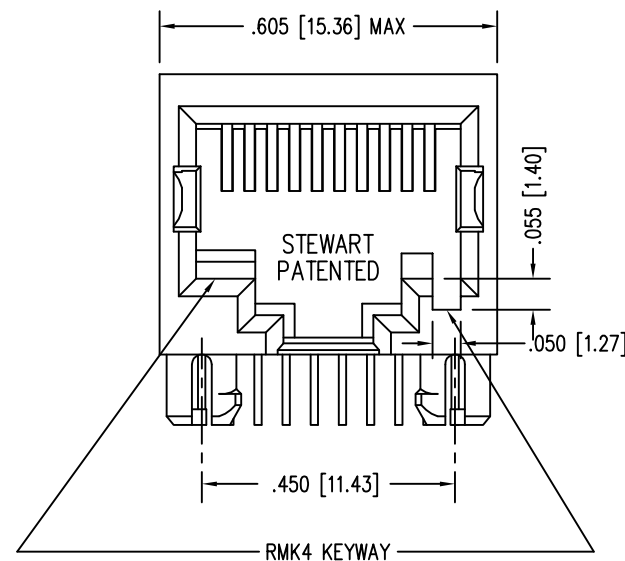
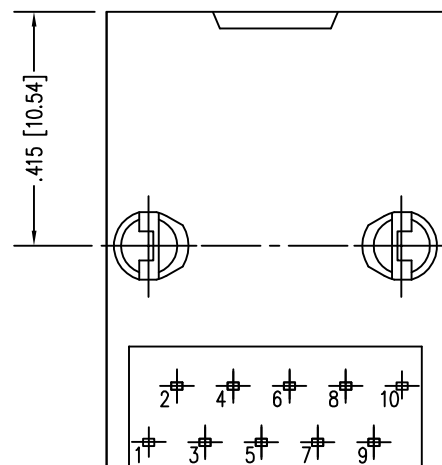

A

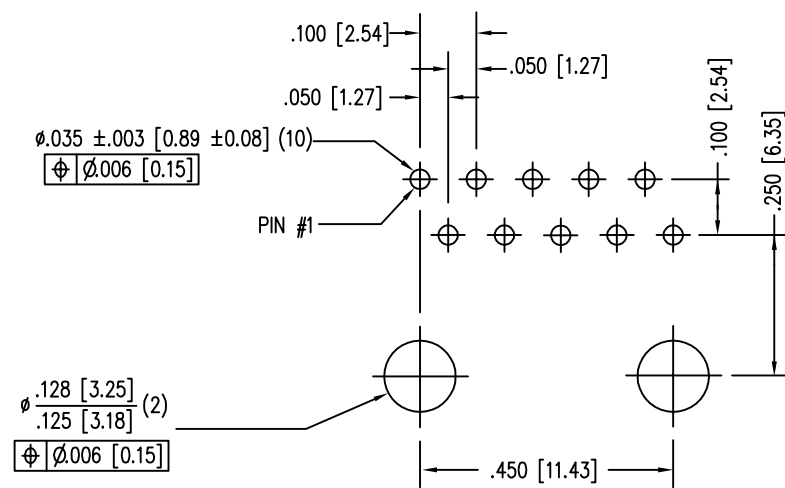

P.C.B. RECOMMENDED HOLE LAYOUT
SEEN FROM COMPONENT SIDE
ALL CENTERLINE DIMENSIONS ARE BASIC.

NOTES:

- CONNECTOR MATERIALS:
HOUSING: THERMOPLASTIC UL94 V-0
CONTACTS: COPPER ALLOY
CONTACT PLATING: SELECTIVE GOLD IN CONTACT AREA
SEE CHART FOR PART NUMBER
- FOR PRODUCT SPECIFICATIONS SEE PR022-01.
- DIMENSIONS AND TOLERANCES COMPLY WITH TIA-1096 STANDARD.

30 MICRO-INCHES [0.76um]	SS64100-037F
CONTACT PLATING IN MATING AREA	PART NUMBER

A

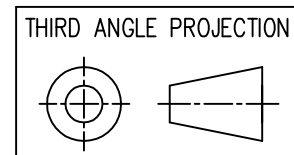

DO NOT SCALE DRAWING
DRAWING IS SUBJECT TO
CHANGE WITHOUT NOTICE

DIMENSIONS: INCHES [METRIC]

UNLESS OTHERWISE SPECIFIED
TOLERANCES ARE ±.005 [0.13]
ANGLES ARE ± 1°

SHEET NO. 1 OF 1

1118 Susquehanna Trail South
Glen Rock, PA 17327-9199
(717) 235-7512
<http://www.stewartconnector.com>

TITLE: TEN CONTACT, TEN POSITION JACK
NON-FLANGE, RMK KEY OPTION

DRN BY: RVO	DATE 3-18-05
APPD BY: RGC	DATE 3-21-05
DWG NO. CT640063F	REV. B4

THIS DRAWING AND THE SUBJECT MATTER SHOWN THEREON ARE CONFIDENTIAL AND THE PROPRIETARY PROPERTY OF STEWART CONNECTOR AND SHALL NOT BE REPRODUCED, COPIED, OR USED IN ANY MANNER WITHOUT PRIOR WRITTEN CONSENT OF STEWART CONNECTOR. ONE OR MORE U.S. PATENTS MAY APPLY TO THIS PRODUCT. FOR DETAILS, PLEASE VISIT: [HTTP://BELFUSE.COM/STEWART/STEWART_PATENTS/](http://BELFUSE.COM/STEWART/STEWART_PATENTS/)

