



ISL Products International

ø38mm Planetary Gear Motor Carbon - Brushed MOT-I-81584-IG38E

Online ID#: PGM-38P-24-51-125-02E

Our Planetary Gear Motors are an inline solution providing excellent torque output at various speeds. They are best for intermittent duty operation. With endless performance combinations, we have a fully tailored gear motor solution for you.

Contact Us for alternative solutions!



Specifications			
Gearhead Type:	Planetary	No-Load Speed:	125 rpm (+/- 10%)
Motor Type:	Carbon - Brushed	No-Load Current:	< 0.50 A
Rated Voltage:	24V DC	Stall Torque:	87 kg.cm
Rated Speed:	103 rpm	Max. Power:	27 W
Rated Torque:	15 kg.cm	Reduction Ratio:	51:1
Termination Style:	Connector: JST PHR-6	Encoder Type:	Magnetic (1-Ch.-7PPR)

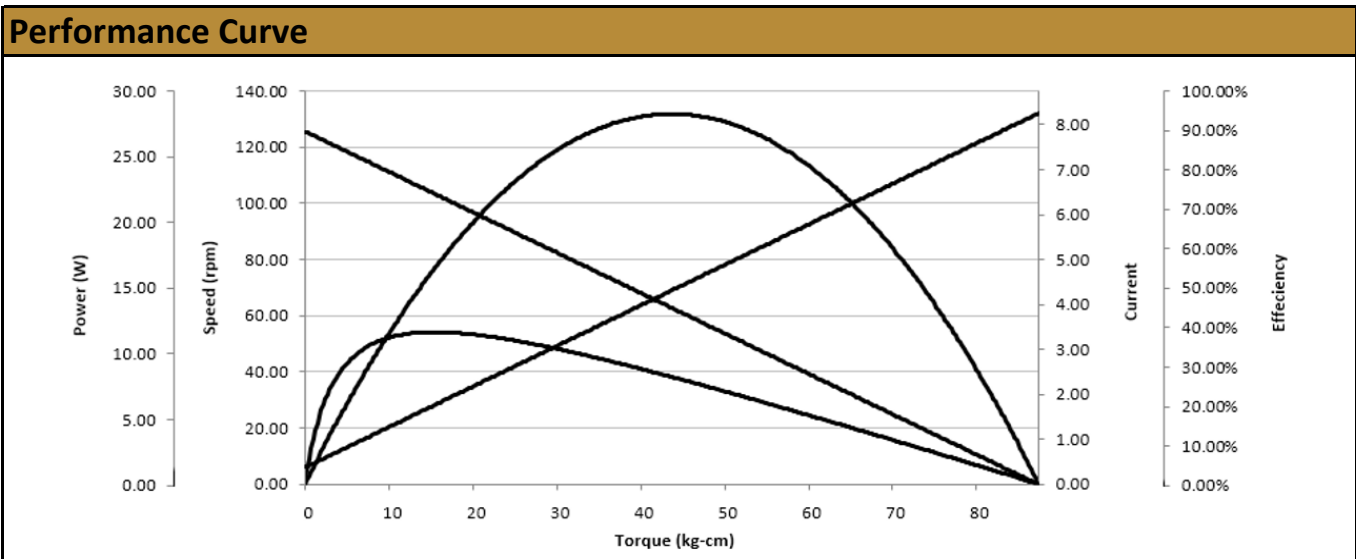
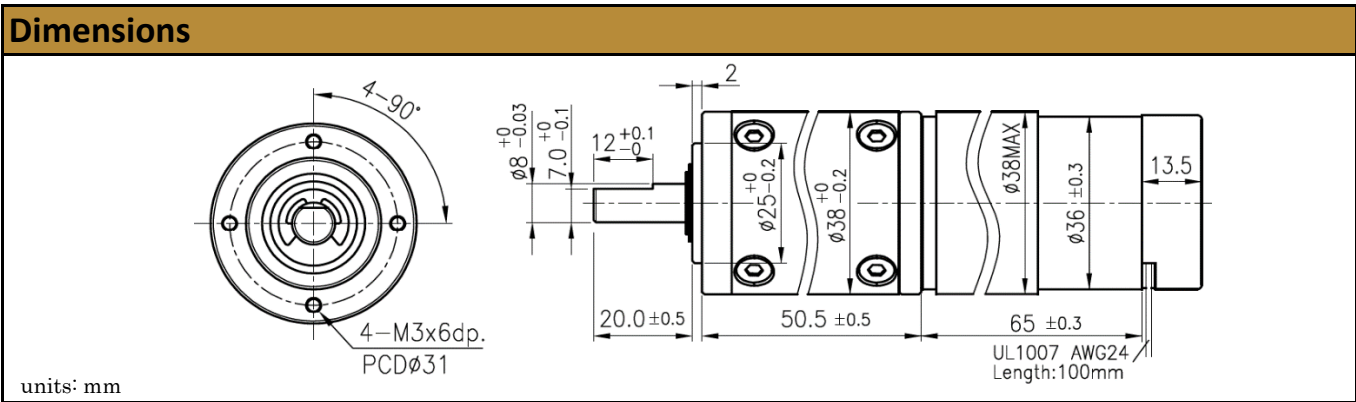



This gear motor is equipped with one of our magnetic encoders to provide exceptional feedback and control.



Specifications

Type:	Magnetic	Min. Operating Temp:	-10°C / 14°F
Channel(s):	1	Max. Operating Temp:	60°C / 140°F
Pulses per Revolution:	7 PPR	Max. Humidity:	85% (RH)
Supply Voltage:	3.5V - 20Vcc	Number of Wires:	6
Supply Current:	10mA (max.)	Connector Type:	JST PHR-6

Dimensions / Connections

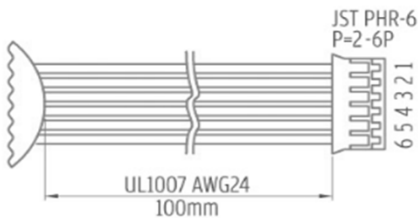

Encoder Connections		
1	Black	(-) Motor
2	Red	(+) Motor
3	Brown	Hall Sensor Vcc
4	Green	Hall Sensor GND
5	Blue	Hall Sensor A – V Out
6	Purple	-----

Electrical Characteristics

Output Circuit

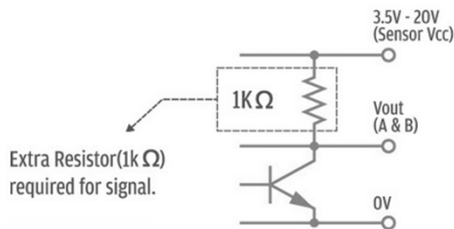

Output Wave

