

PART NUMBER	REV	FIRST USED
680038-1	B	854400-1
680038-2	B	565435-5
680038-3	B	354500-1

PRELIMINARY

PRELIMINARY

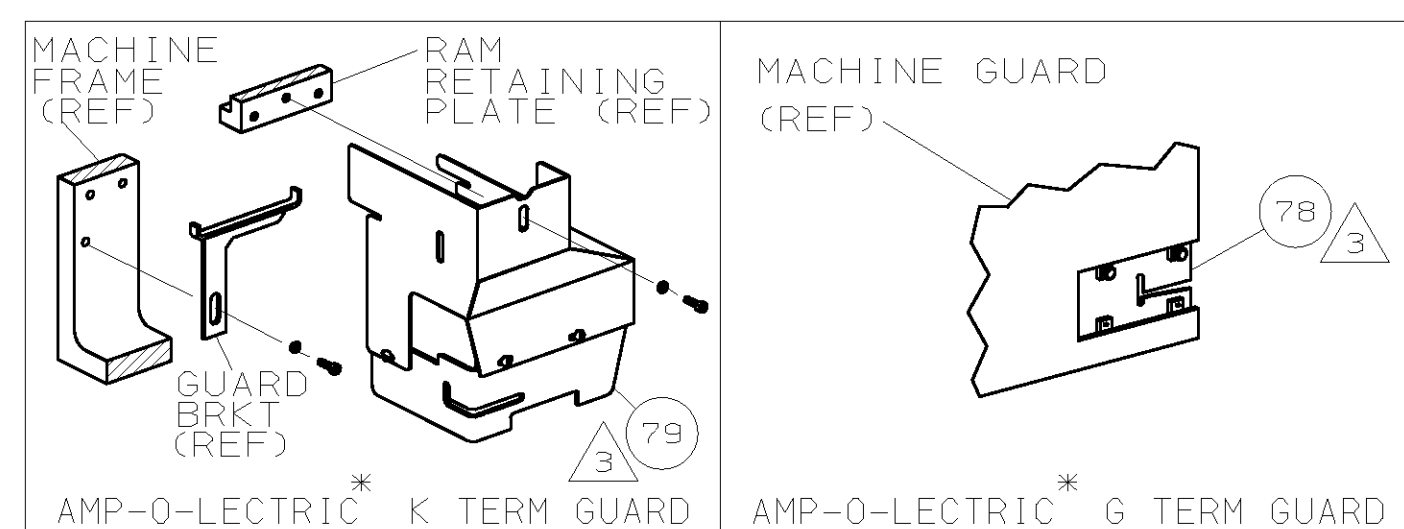

TERMINAL NAME:		CRIMPING DATA	
.250 FASTON			
	42437	PAD LTR	CRIMP HEIGHT
		A	.115 ±.002
		B	.100 ±.002
		C	.095 ±.002
		D	.083 ±.002
		CRIMP	SIZE
		WIRE	.130
		INSUL	.170
		FEED	.841
		APPL INST	458638-1
		SET UP GAGE	LAYOUT
			3
		WIRE STRIP LENGTH	-

QTY	REV	LEADMAKER	AIRFEED	ITEM NO
-1		BENCH MODEL K	AIRFEED	70
-2		BENCH MODEL G	AIRFEED	69
-3				68
-	1	-	C	692655-5
-	REF	-	A	24042-2
-	REF	-	C	692655-6
1	1	1	-	B
2	2	2	-	A
1	-	1	-	A
1	-	1	-	A
12.00	12.00	12.00	IN	A

THIS DRAWING IS A CONTROLLED DOCUMENT.

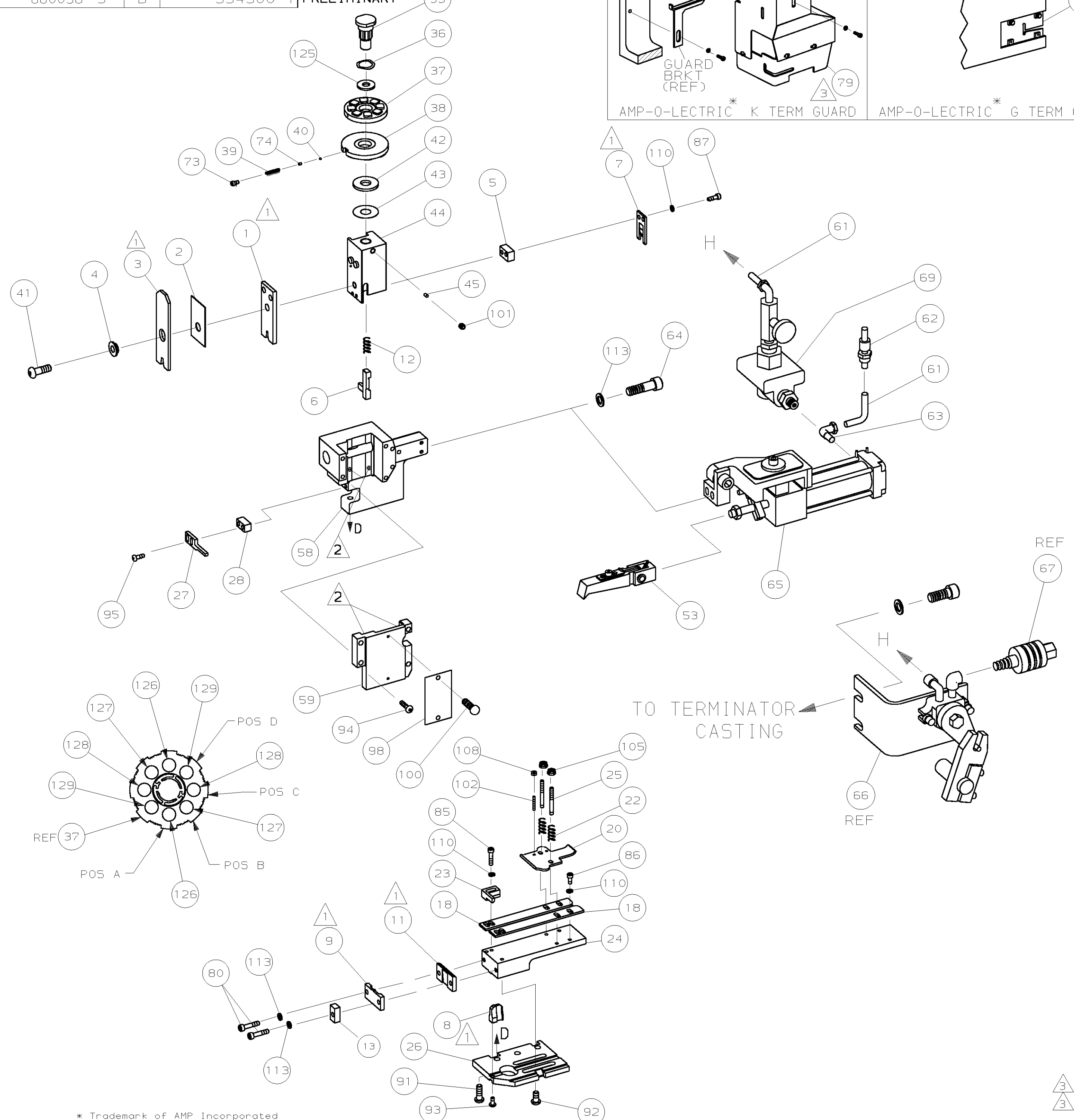

- 1 RECOMMENDED SPARE PARTS.
- 2 GREASE LIGHTLY.
- 3 GUARD MUST BE IN PLACE WHEN OPERATING APPLICATOR IN AMP-0-LECTRIC MACHINE.
- 4 SEE DRAWING FOR COMPONENTS

QTY	REV	LEADMAKER	AIRFEED	ITEM NO	DESCRIPTION
2	2	2	-	C	354779-6
2	2	2	-	C	8-354778-1
2	2	2	-	C	7-354778-1
2	2	2	-	C	3-354778-9
1	1	1	-	A	986950-1
					PIN, WIRE DISC (.3020)D
					PIN, WIRE DISC (.2900)C
					PIN, WIRE DISC (.2850)B
					PIN, WIRE DISC (.2690)A
					WASHER, FLAT PRECISION
					129
					128
					127
					126
					125
					124
					123
					122
					121
					120
					119
					118
					117
					116
					115
					114
4	4	4	-	A	21024-5
					WASHER, LOCK (NO.10) SHEAR PL
					113
					112
					111
7	7	7	-	A	21024-4
					WASHER, LOCK (NO.8) SHEAR BL
					110
					109
2	2	2	-	A	21018-4
					NUT, HEX (4-40) DRAG
					108
					107
					106
2	2	2	-	A	21022-2
					NUT, HEX 5L (8-32) DRAG STUD
					105
					104
					103
2	2	2	-	A	4-21078-8
					SKT SKT SET (4-40x.75) DRAG
					102
1	1	1	-	A	21009-2
					SCR, SKT SET (1/4-20x.25) RAM
					101
2	2	2	-	A	21017-2
					SCR, DRIVE (#2x.19) ID PLATE
					100
					99
1	1	1	-	B	461264-1
					PLATE, IDENTIFICATION
					98
					97
					96
2	2	2	-	A	2-21002-2
					SCR, BHC (8-32x.50) STRIPPER
					95
4	4	4	-	A	2-21002-9
					SCR, BHC (10-32x.75) CAP
					94
1	1	1	-	A	22733-8
					SCR, BHC (8-32x.38 LW) ANVIL
					93
4	4	4	-	A	3-21002-3
					SCR, BHC (1/4-20x.50) ST 6D PL
					92
3	3	3	-	A	2-22733-8
					SCR, BHC (1/4-20x.62) H5G
					91
					90
					89
					88
2	2	2	-	A	2-21000-7
					SCR, 5HC (8-32x.50) SLUG BLADE
					87
3	3	3	-	A	2-21000-6
					SCR, 5HC (8-32x.38) STRIP GUIDE
					86
2	2	2	-	A	2-21000-9
					SCR, 5HC (8-32x.75) R STRIP GUIDE
					85
					84
					83
					82
					81
2	2	2	-	A	3-21000-8
					SCR, SKT CAP (10-32x.88) 5H PL
					80
-	1	-	-	A	455750-7
					GUARD ASSY
					79
REF	-	-	-	A	679532-1
					INSERT, GUARD
					78
					77
					76
					75
1	1	1	-	A	690603-1
					SPRING, ASSIST
					74
1	1	1	-	A	23030-1
					SCR, SKT CAP (6-32x.25) CP DSC
					73
					72
					71

QTY	REV	LEADMAKER	AIRFEED	ITEM NO	DESCRIPTION
-3	-2	-1	U/M	DWG SIZE	PART NO
					REVISION OF EACH ASSY NO (WHEN BLANK, USE DWG REVISION)
					QTY REOD PER ASSY
					PARTS LIST
					129
					128
					127
					126
					125
					124
					123
					122
					121
					120
					119
					118
					117
					116
					115
					114
					113
					112
					111
					110
					109
					108
					107
					106
					105
					104
					103
					102
					101
					100
					99
					98
					97
					96
					95
					94
					93
					92
					91
					90
					89
					88
					87
					86
					85
					84
					83
					82
					81
					80
					79
					78
					77
					76
					75
					74
					73
					72
					71

THIS DRAWING IS UNRELEASED. RELEASE FOR PUBLICATION BY AMP INCORPORATED. ALL RIGHTS RESERVED. COPYRIGHT 1993

LOC A DIST 66