

## 120W, 9 to 36V Input Industrial Isolated Quarter Brick DC-DC Converter

<https://product.tdk.com/en/power/gqa>  
[www.emea.lambda.tdk.com/gqa](http://www.emea.lambda.tdk.com/gqa)



The GQA series of isolated DC-DC converters deliver 120W in a compact and high performance quarter brick footprint. It operates from an input range of 9 to 36V and comes with a broad selection of output voltages. The mechanical packaging is available in multiple baseplate, enclosed and potted configurations, supporting convection and conduction cooling via external cold plate or heatsink. It's designed to deliver high useable power at elevated temperatures and withstand high shock and vibration exposure in rugged industrial and battery powered autonomous mobility applications.

Features	Benefits
• 120W in an Industry Quarter Brick Footprint	• High Power Density, Less Board Area Needed
• 9 to 36V Input Range	• Can Operate From Different Input DC Sources Including Battery
• Flanged and Non-Flanged Baseplate Design	• Conduction Cooling Mounting Flexibility for Cold Plate or Heatsink
• Maximum Baseplate Temperature of 105°C	• High Useable Power at Elevated Temperatures
• Enclosed and Potted Options	• Operation in Harsh Environment With High Shock and Vibration Exposure

### Model Selector (Full Systems)

Model	Input Voltage (V)	Output Voltage (V)	Max Current (A)	Max Power (W)	Remote Sense	Baseplate	Enclosed with Potting	Input to Output Isolation
<a href="#">GQA2W024A050V-007-R</a>	9 - 36	5	24	120	Yes	Flanged	No	1500 Vdc
<a href="#">GQA2W024A050V-0P7-R</a>	9 - 36	5	24	120	Yes	Flanged	Yes	3000 Vdc
<a href="#">GQA2W024A050V-N07-R</a>	9 - 36	5	24	120	Yes	Non-Flanged	No	1500 Vdc
<a href="#">GQA2W024A050V-NP7-R</a>	9 - 36	5	24	120	Yes	Non-Flanged	Yes	2250 Vdc
<a href="#">GQA2W010A120V-007-R</a>	9 - 36	12	10	120	Yes	Flanged	No	1500 Vdc
<a href="#">GQA2W010A120V-0P7-R</a>	9 - 36	12	10	120	Yes	Flanged	Yes	3000 Vdc
<a href="#">GQA2W010A120V-N07-R</a>	9 - 36	12	10	120	Yes	Non-Flanged	No	1500 Vdc
<a href="#">GQA2W008A150V-007-R</a>	9 - 36	15	8	120	Yes	Flanged	No	1500 Vdc
<a href="#">GQA2W008A150V-0P7-R</a>	9 - 36	15	8	120	Yes	Flanged	Yes	3000 Vdc
<a href="#">GQA2W008A150V-N07-R</a>	9 - 36	15	8	120	Yes	Non-Flanged	No	1500 Vdc
<a href="#">GQA2W005A240V-007-R</a>	9 - 36	24	5	120	NA	Flanged	No	1500 Vdc
<a href="#">GQA2W005A240V-0P7-R</a>	9 - 36	24	5	120	NA	Flanged	Yes	3000 Vdc
<a href="#">GQA2W005A240V-N07-R</a>	9 - 36	24	5	120	NA	Non-Flanged	No	1500 Vdc
<a href="#">GQA2W005A240V-NP7-R</a>	9 - 36	24	5	120	NA	Non-Flanged	Yes	2250 Vdc
<a href="#">GQA2W004A280V-007-R</a>	9 - 36	28	4.28	120	NA	Flanged	No	1500 Vdc
<a href="#">GQA2W004A280V-0P7-R</a>	9 - 36	28	4.28	120	NA	Flanged	Yes	3000 Vdc
<a href="#">GQA2W004A280V-N07-R</a>	9 - 36	28	4.28	120	NA	Non-Flanged	No	1500 Vdc
<a href="#">GQA2W004A280V-NP7-R</a>	9 - 36	28	4.28	120	NA	Non-Flanged	Yes	2250 Vdc
<a href="#">GQA24003A480V-007-R</a>	18 - 36	48	2.5	120	NA	Flanged	No	1500 Vdc
<a href="#">GQA24003A480V-0P7-R</a>	18 - 36	48	2.5	120	NA	Flanged	Yes	3000 Vdc
<a href="#">GQA24003A480V-N07-R</a>	18 - 36	48	2.5	120	NA	Non-Flanged	No	1500 Vdc

<b>GQA</b>	<b>2W</b>	<b>005A</b>	<b>240V</b>	<b>-</b>	<b>007</b>	<b>-</b>	<b>R</b>
	Input Voltage 2W: 9 - 36V 24: 18 - 36V	Output Current 005A: 5A 010A: 10A	Output Voltage: 240V : 24V 050V : 5V		Baseplate Construction: 007 : Flanged Baseplate 0P7 : Flanged Baseplate, Enclosed / Potted, 3kV Isolation N07: Non-Flanged Baseplate NP7: Non-Flanged Baseplate, Enclosed / Potted		R : RoHS Compliant

Related Products		
Type	Part Number	Description
Isolated DC-DC Converter	<a href="#">HQA120</a>	120W MIL-COTS, Input 9-40V, Isolated Quarter Brick with M-Grade screening available
Isolated DC-DC Converter	<a href="#">HQA85</a>	85W MIL-COTS, Input 9-40V, Isolated Quarter brick
Input Filter	<a href="#">FQA</a>	40V / 20A MIL-COTS Filter for MIL-STD-461
Input Filter	<a href="#">FQB</a>	40V / 20A MIL-COTS Filter for MIL-STD-461; MIL-STD-1275; MIL-STD-704; DO-160G
Evaluation Board	<a href="#">FQX-HQA-EVK-D0</a>	Evaluation board (no modules) that fits 2X HQA or GQA DC-DC converters and FQx input filters

Specifications								
Model		5	12	15	24	28	48	
<b>Input</b>								
Input Voltage Range	Vdc	9 - 36					18 - 36	
Input Transient (t < 1s)	Vdc	50						
Input Current (max)	A	17					10	
Turn-ON Input Voltage	Vdc	9.5					17	
Turn-OFF Input Voltage	Vdc	8.5					15.5	
Efficiency (typical)	%	90	89	89	87	89	91.5	
Safety Certifications and Markings	-	IEC/UL/CSA/EN 62368-1, 60950-1, CE Mark and UKCA Mark						
<b>Output</b>								
Output Voltage Tolerance	%	±4 (Rated input, Load and Temperature)						
Output Voltage Adjustment Range	Vdc	4.5 - 5.5	10.8 - 13.2	13.5 - 16.5	21.6 - 26.4	25.2 - 30.8	45.6 - 52.8	
Line Regulation	%	0.05						
Load Regulation	%	0.03						
External Load Capacitance	µF	47 - 2400	0 - 1800	0 - 1500	0 - 1000	0 - 1000	0 - 1000	
Ripple & Noise (typ)	mVpp	40	40	80	100	100	125	
Switching Frequency	kHz	270						
Overcurrent Protection Threshold (typ)	A	37	14.5	12	6.2	5.1	4	
Over Voltage Protection (typ)	Vdc	6.5	15	18	32	35	54	
Over Temperature Protection	-	Shutdown - Autorecovery						
<b>Environmental</b>								
Operating Temperature (Tc)	°C	-40 to 105						
Storage Temperature	°C	-55 to 125						
Humidity (non condensing)	%RH	10 - 95						
Cooling	-	Conduction Cooling						
Isolation Voltage (Input to Output)	Vdc	007-R / N07-R : 1500 0P7-R : 3000 NP7-R : 2250						
Isolation Voltage (Baseplate to Input or Output)	Vdc	007-R / N07-R : 1500 0P7-R / NP7-R : 2250						
Isolation Resistance	MΩ	> 10						
Shock	-	MIL-STD 810G, Method 516.6, Procedure I, VI						
Vibration	-	MIL-STD-810G, Method 514.6, Procedure I, Category 14						
<b>Other</b>								
Weight (max)	g	85						
Size (LxWxH)	mm	Flanged Baseplate : 60.6 x 49.5 x 12.7 Non Flanged Baseplate: 60.6 x 39.5 x 12.7						
Size (LxWxH)	Inches	Flanged Baseplate : 2.39 x 1.95 x 0.5 Non Flanged Baseplate: 2.39 x 1.56 x 0.5						
MTBF - Telcordia SR-332	-	> 4 Mhrs; 100% Load; Ta = 40 °C						
Warranty	yrs	3						

Notes  
See website for detailed product [specifications](#).

## Mechanical Specification:

### -007-R Suffix / Flanged Baseplate

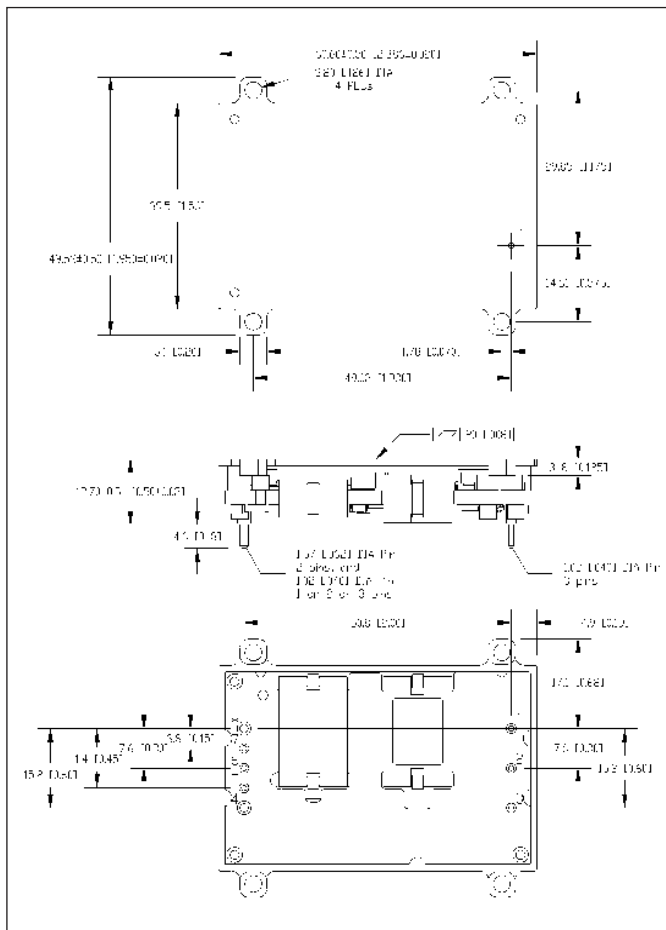

### -N07-R Suffix / Non-Flanged Baseplate

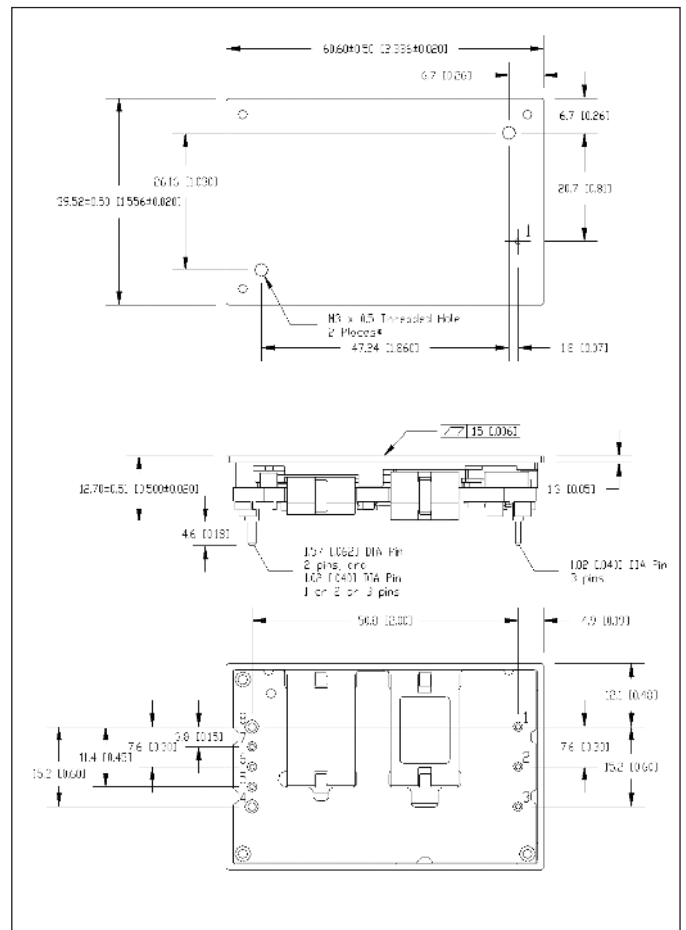

Note: Dimensions are in mm [in].

Unless otherwise specified, tolerances are x.x [x.xx] ±0.5 [0.02], x.xx [x.xxx] ±0.25 [0.010]

For Non-Flanged Baseplates, the depth of M3 mounting screws cannot exceed 3.0mm [0.12"].

### Pinout

Pin	Function	Pin	Function
1	Vin(+)	5	sense (-), select models*
2	On/Off	6	Trim
3	Vin(-)	7	Sense (+), select models*
4	Vo(-)	8	Vo(+)

Pin base material is tellurium copper with tin over nickel plating.

\* Sense pins are available on 5, 12 and 15 V models.

**Mechanical Specification:**

**-0P7-R Suffix / Flanged Baseplate, Enclosed /Potted**

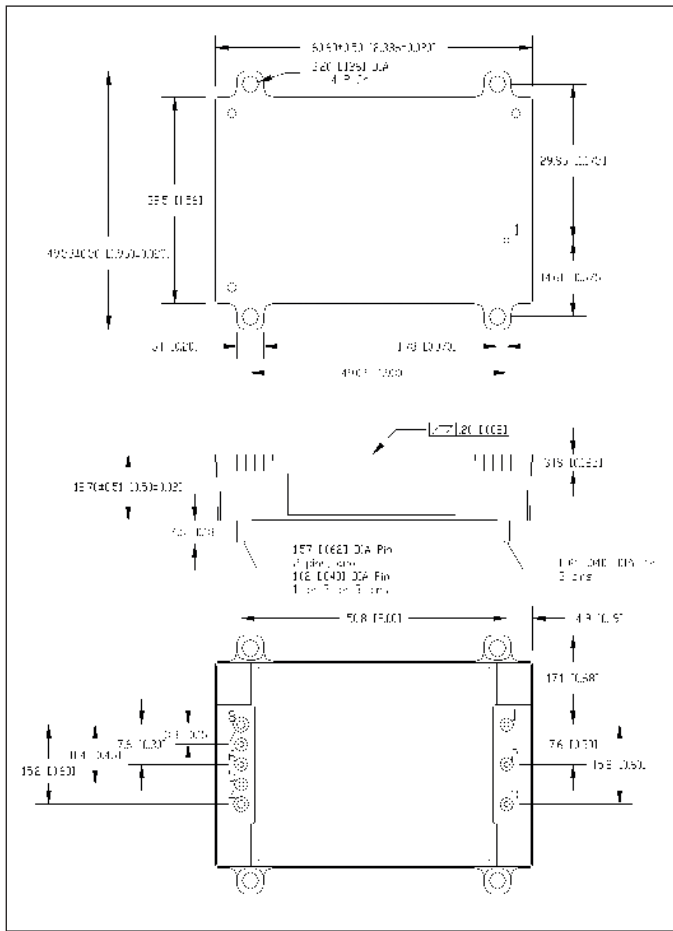

**-NP7-R Suffix / Non-Flanged Baseplate, Enclosed/Potted**

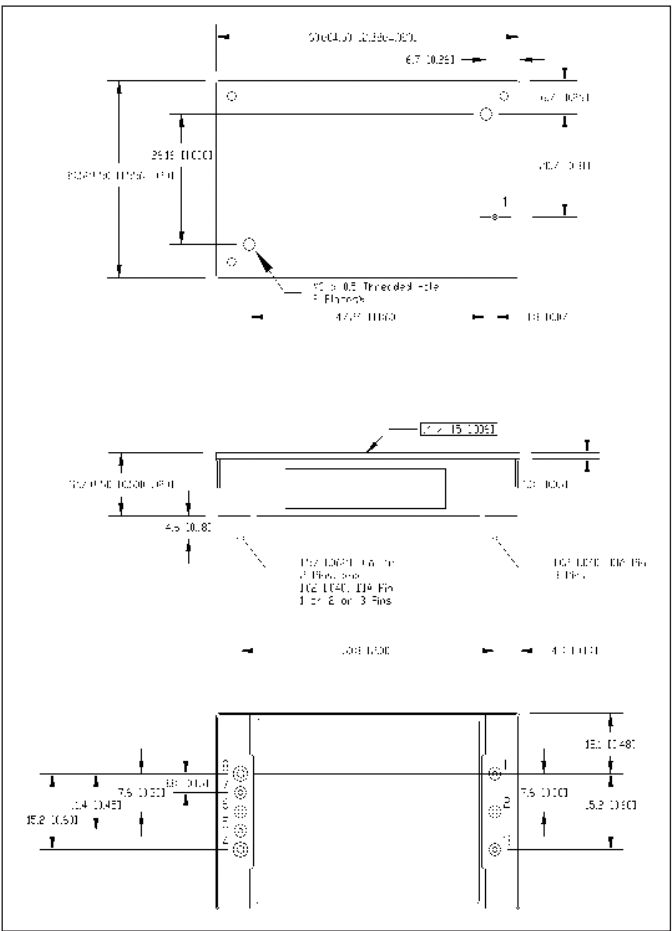

Note: Dimensions are in mm [in].  
 Unless otherwise specified, tolerances are x.x [x.xx] ±0.5 [0.02], x.xx [x.xxx] ±0.25 [0.010]  
 For Non-Flanged Baseplates, the depth of M3 mounting screws cannot exceed 3.0mm [0.12"].

**Recommended Hole Pattern:**

(Pin Side Down – Flanged Baseplate)

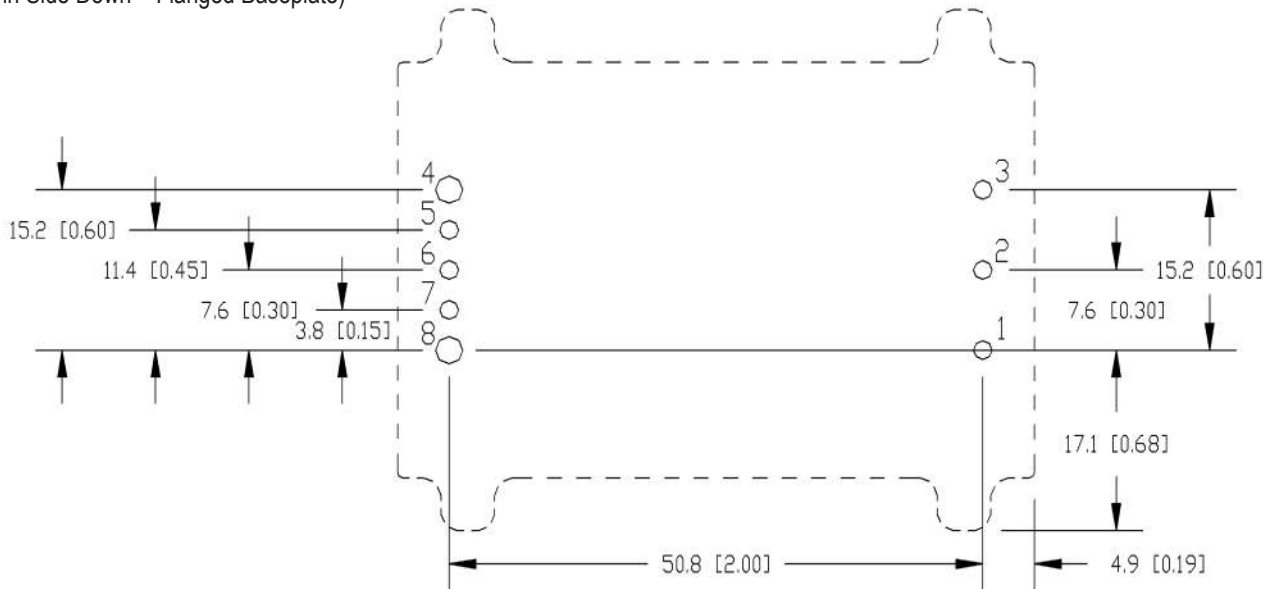

(Pin Side Down – Non-Flanged Baseplate)

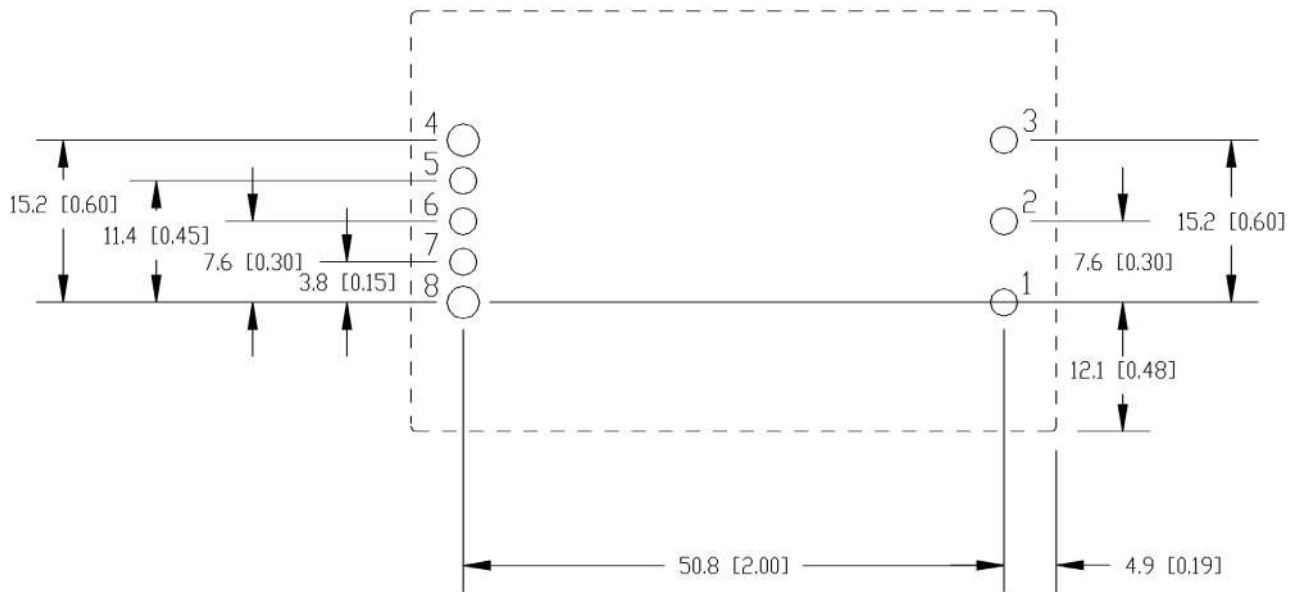



**TDK-Lambda France SAS**

Tel: +33 1 60 12 71 65  
 tf.fr.powersolutions@tdk.com  
 www.emea.lambda.tdk.com/fr



**Italy Sales Office**

Tel: +39 02 61 29 38 63  
 tf.it.powersolutions@tdk.com  
 www.emea.lambda.tdk.com/it



**Netherlands**

tf.nl.powersolutions@tdk.com  
 www.emea.lambda.tdk.com/nl



**TDK-Lambda Germany GmbH**

Tel: +49 7841 666 0  
 tlg.powersolutions@tdk.com  
 www.emea.lambda.tdk.com/de



**Austria Sales Office**

Tel: +43 2256 655 84  
 tlg.at.powersolutions@tdk.com  
 www.emea.lambda.tdk.com/at



**Switzerland Sales Office**

Tel: +41 44 850 53 53  
 tlg.ch.powersolutions@tdk.com  
 www.emea.lambda.tdk.com/ch



**Nordic Sales Office**

Tel: +45 8853 8086  
 tlg.dk.powersolutions@tdk.com  
 www.emea.lambda.tdk.com/dk



**TDK-Lambda UK Ltd.**

Tel: +44 (0) 12 71 85 66 66  
 tlu.powersolutions@tdk.com  
 www.emea.lambda.tdk.com/uk



**TDK-Lambda Ltd.**

Tel: +9 723 902 4333  
 tli.powersolutions@tdk.com  
 www.emea.lambda.tdk.com/il-en



**TDK-Lambda Americas**

Tel: +1 800-LAMBDA-4 or 1-800-526-2324  
 tla.powersolutions@tdk.com  
 www.us.lambda.tdk.com



**TDK Electronics do Brasil Ltda**

Tel: +55 11 3289-9599  
 sales.br@tdk-electronics.tdk.com  
 www.tdk-electronics.tdk.com/en



**TDK-Lambda Corporation**

Tel: +81-3-6778-1113  
 www.jp.lambda.tdk.com



**TDK-Lambda (China) Electronics Co. Ltd.**

Tel: +86 21 6485-0777  
 tlc.powersolutions@tdk.com  
 www.lambda.tdk.com.cn



**TDK-Lambda Singapore Pte Ltd.**

Tel: +65 6251 7211  
 tls.marketing@tdk.com  
 www.sg.lambda.tdk.com



**TDK India Private Limited, Power Supply Division**

Tel: +91 80 4039-0660  
 mathew.philip@tdk.com  
 www.sg.lambda.tdk.com

