

100A type

FEATURES

- Compact and high capacity using double contacts in series and permanent magnet installed. (1,000A/3 times) cut-off possible (EB Relay 100A type)
- Compact and lightweight for space savings and improved gas mileage.

TYPICAL APPLICATIONS

Equipment requiring high capacity cutoff such as main power supplies for 42 V vehicles, motor assisters, quick recharging power supplies for AGVs (automatic guided vehicle), and motor controls for forklifts, etc.

RoHS Directive compatibility information
<http://www.nais-e.com/>

SPECIFICATIONS

Contact		100A	Characteristics		100A
Type		100A	Type		100A
Arrangement		1 Form A	Initial insulation resistance*3 (Initial) (at 500 V DC)		Min. 100MΩ
Between terminal voltage drop (Initial)		Max. 0.15 V (at 100 A), Max. 0.05 V (at 10 A), Max. 0.01 V (at 1 A)	Initial breakdown voltage (Initial)	Between open contacts	AC 1,500 Vrms for min.
Material		Ag alloy (Cadmium free)		Between contact and coil	AC 2,500 Vrms for 1 min.
Rating	Nominal switching capacity (resistive load)	100A 42V DC	Operate time (at 20°C) (at nominal voltage)		Max. 30ms*4
	Max. carrying current	1,000A (0.1s)	Release time (at 20°C) (at nominal voltage)		Max. 15ms
	Min. switching capacity #1	1A 12V DC	Shock resistance	Functional*5	Min. 196 m/s ² {20.4G}
	Max. cut-off current	1,000A 42V DC/ 3 cycle*1		Destructive*6	Min. 980 m/s ² {100G}
	Overload opening/closing rating	400A 55V DC/ 10 cycle	Vibration resistance		Functional*7 44.1 m/s ² {4.5G} 10 to 500Hz Destructive*8 44.1 m/s ² {4.5G} 10 to 200 Hz
Expected life (min. operations)	Mechanical	10 ⁶	Conditions for operation, transport and storage*9		Ambient temperature -40°C to +85°C -40°F to +185°F
	Electrical*2	10 ⁴ (at 100A 42V DC)	Mass		

Notes:
 #1 This value can change due to the switching frequency, environmental conditions, and desired reliability level, therefore it is recommended to check this with the actual load.
 • When using a surge absorbing element for the relay coil drive circuit, please use with a surge absorbing element with a clamp voltage of "Rating voltage x 1.5: 18V/36V/54V" or more. When the coil is connected in parallel with a diode, resistor or capacitor, the revert time will delay which might lead to degradation in shutoff performance and electrical working life. Contact terminals have polarity; therefore, please obey the wiring diagram when connecting contacts. The electrical load performance value applies when a varistor is connected in parallel with the coil.

Remarks
 *1 Condition: Condition: Nominal switching 100cycles, each cut off 1,000A
 *2 Resistive load, operating frequency 1s ON, 9s OFF, room temperature
 *3 Measurement at same location as "Initial breakdown voltage" section.
 *4 Nominal voltage applied to the coil, excluding bounce time.
 *5 Half-wave pulse of sine wave: 11 ms; detection time: 10μs, 12V DC applied to the coil.
 *6 Half-wave pulse of sine wave: 6 ms, 12V DC applied to the coil or deenergized.
 *7 12V DC applied to the coil
 *8 12V DC applied to the coil or deenergized.
 *9 Refer to 6. Conditions for operation, transport and storage mentioned in AMBIENT ENVIRONMENT.

ORDERING INFORMATION

Ex. A EB 3 1 0 0

Product Name	Contact arrangement	Contact rating/ Relay shape	Heat resistance grade/ protective element	Terminal shape	Coil voltage
EB	3: 1Form A	1: 100 A / Flat	0: Standard/no protective element	0: Screw terminal	12: 12 V DC 24: 24 V DC 36: 36 V DC

TYPES

Contact arrangement	Coil voltage, V DC	Protective construction	Terminal shape	Part No.
1 Form A	12	Dust cover	Screw terminal	AEB310012
	24			AEB310024
	36			AEB310036

COIL DATA

Type	Coil voltage, V DC	Pick-up voltage, V DC (Initial) (at 20°C)	Drop-out voltage, V DC (Initial) (at 20°C)	Nominal operating current, mA (at 20°C)	Coil resistance, Ω (at 20°C)	Nominal operating power, W (at 20°C)	Usable voltage range, V DC
100A	12	Max. 9.0	Min. 1.0	410±10%	29.0±10%	5.0	10 to 16
	24	Max. 18.0	Min. 2.0	208±10%	115±10%	5.0	20 to 32
	36	Max. 27.0	Min. 3.0	139±10%	260±10%	5.0	30 to 48

DIMENSIONS

mm inch

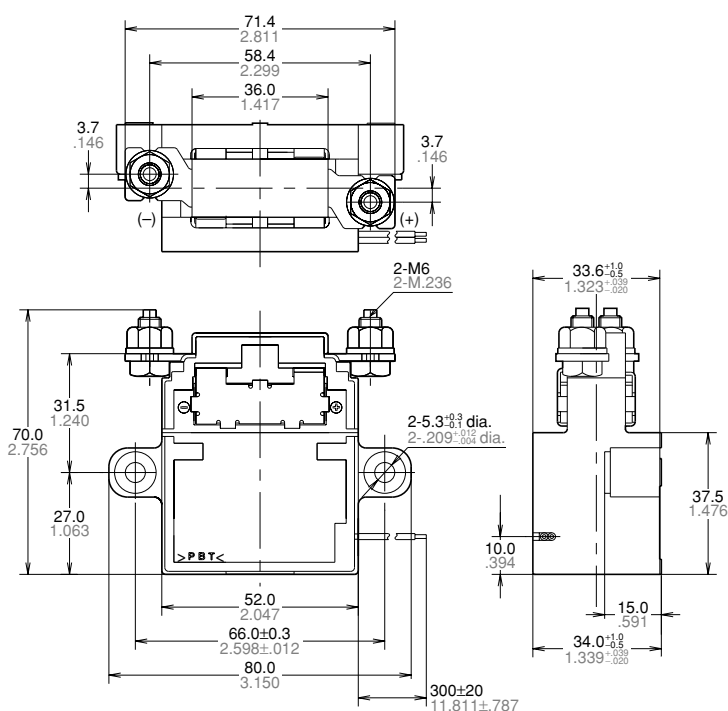

Schematic (TOP VIEW)

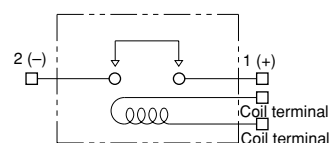

Mounting hole pattern (TOP VIEW)



* Brand display will change successively from October, 2005. NAI S will be deleted and replaced by the "M" mark.

- Notes: 1. Please be warned that contact terminals have polarity. There is no polarity in the coil input line.
 2. We will make separate consideration if a coil lead wire connector is desired.
 3. M6 tighten torque: 6.0 N·m to 8.0 N·m

REFERENCE DATA

1. Operate and release time characteristics
 Sample: AEB310012 (nominal coil voltage 12V type), 1pcs
 Load: Coil applied voltage; 8.0 to 16.0V DC, coil surge protection elements; with zener diode (33V)
 Ambient temperature: 25°C 77°F

Coil applied voltage vs operate and release time

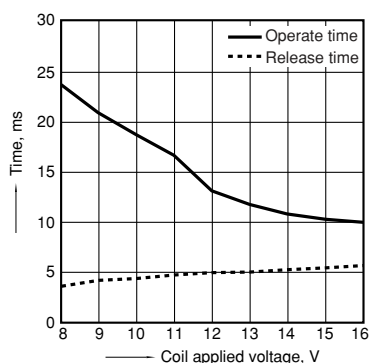

Circuit:

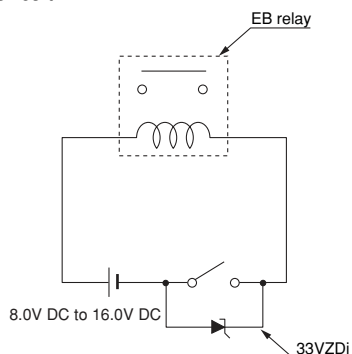

EB (AEB)

2. Ambient temperature characteristics

Sample: AEB310012 (nominal coil voltage 12V type), 5pcs

Ambient temperature (°C)	-35	20	80
Standard value (V)	—	9.0	—
Actual value (V)	5.4	6.7	8.3

Ambient temperature vs pick-up voltage (Cold start)

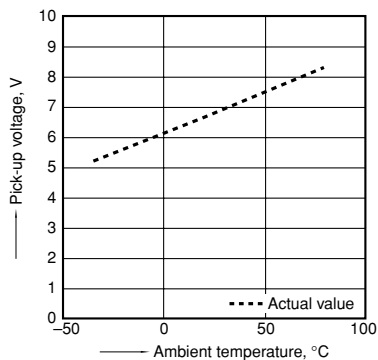

3. Carrying current limit (error assumed)

Sample: AEB310012 (nominal coil voltage 12V type), 1pcs

Connection electric wire: 40mm²

Ambient temperature: 85°C 185°F

Standard for judgment: Relay contacts off when carrying finished.

Carrying current and carrying time

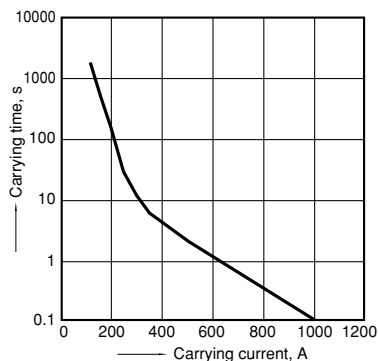

4. Cut-off characteristics

Sample: AEB310012 (nominal coil voltage 12V type), 2pcs

Load: Coil applied voltage; 14V DC

Ambient temperature: Room temperature

Max. cut-off current:

(1) 300A (42V DC: resistive load)

(2) 1,000A (42V DC: resistive load)

Operating cycle:

(1) 300A/10 cycles

(2) 1,000A/3 cycles

(1) Cut off current/voltage: 300A/42V DC (resistive load)

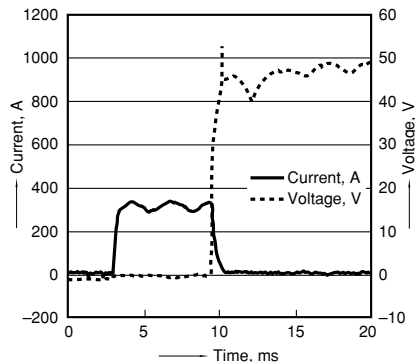

(2) Cut-off current/voltage: 1,000A/42V DC (resistive load)

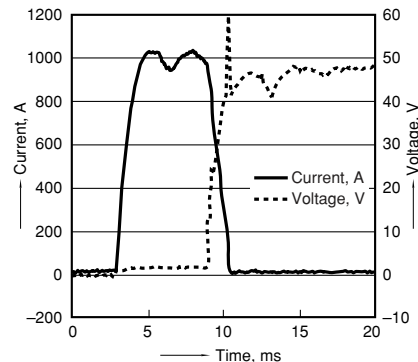

NOTES

1. To ensure proper operation, the voltage applied to the coil should be the rated operating voltage of the coil. Also, be aware that the pick-up and drop-out voltages will fluctuate depending on the ambient temperature and operating conditions.

2. Heat, smoke, and even a fire may occur if the relay is used in conditions outside of the allowable ranges for the coil ratings, contact ratings, operating cycle lifetime, and other specifications. Therefore, do not use the relay if these ratings are exceeded.

3. If the relay has been dropped, the appearance and characteristics should always be checked before use.

4. When using this relay for AC load switching, caution is required. Please contact us.

5. Make sure that the relay is wired correctly. Incorrect wiring may cause unexpected events or the generation of heat or flames.

6. We recommend you use a surge absorbing element with a clamp voltage of "Rating voltate x1.5: 18V/36V/54V" or more for the relay coil drive circuit as a means for relay coil surge absorption. Please avoid the use of diodes, capacitors and resistors because they lead to degradation in cut-off performance.

7. Avoid mounting the relay in strong magnetic fields (near a transformer or magnet) or close to an object that radiates heat.

8. Electrical life

This relay is a high-voltage direct-current switch. In its final breakdown mode, it may lose the ability to provide the proper cut-off. Therefore, do not exceed the indicated switching capacity and life. (Please treat the relay as a product with limited life and replace it when necessary.)

In the event that the relay loses cut-off ability, there is a possibility that burning may spread to surrounding parts, so configure the layout so that the power is turned off within one second.

9. If the power is turned off and then immediately on after applying the rated voltage (current) continuously to the relay's coil and contact, the resistance of the coil will increase due to a rise in the coil temperature. This causes the pick-up voltage to rise, and possibly exceed the rated pick-up voltage. In these circumstances, take measures such as reducing the load current, limiting the duration of current flow, and applying a coil voltage higher than the rated operating voltage (quick start).

10. If you are using an inductive load (L load) such that $L/R > 1$ ms, add surge protection in parallel with the inductive load. If this is not done, the electrical life will decrease and cut-off failure may occur.

11. Be careful that foreign matter and oils and fats kind doesn't stick to the main terminal part because it is likely to cause a terminal part to give off unusual heat.

12. Avoid excessive load applied to the terminal in case of installing such as a bus bar etc., because it might give bad influence to the opening and closing performance.

Tighten each of the screws within the rated ranges given below.

Main terminal (M6 screw):

6.0N·m to 8.0N·m

Main unit mounting (M5 screw):

2.5N·m to 3.6N·m

13. Usage, transport and storage conditions

Ambient temperature, humidity, and atmospheric pressure during usage, transport, and storage of the relay:

1) Temperature: -40 to +85°C -40 to +185°F

2) Humidity: 5 to 85% RH

(Avoid freezing and condensation.)

3) Atmospheric pressure: 85 to 106 kPa
Temperature and humidity range for usage, transport, and storage:

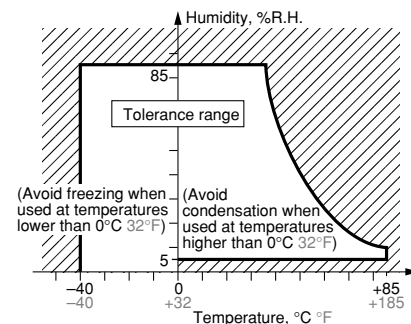

4) Condensation

Condensation forms when there is a sudden change in temperature under high temperature and high humidity conditions. Condensation will cause deterioration of the relay insulation.

5) Freezing

Condensation or other moisture may freeze on the relay when the temperatures is lower than 0°C 32°F. This causes problems such as sticking of movable parts or operational time lags.

6) Low temperature, low humidity environments

The plastic becomes brittle if the relay is exposed to a low temperature, low humidity environment for long periods of time.