

Low Voltage Dual SPDT Analog Switch 2:1 Mux/Demux Bus Switch

Features

- CMOS Technology for Bus and Analog Applications
- Low On-Resistance: 8Ω at 3.0V
- Wide V_{CC} Range: 1.65V to 5.5V
- Rail-to-Rail Signal Range
- Control Input Overvoltage Tolerance: 5.5V(Min)
- Fast Transition Speed: 2ns at 5.0V
- High Off Isolation: -63dB @ 10MHz
- Break-Before-Make Switching
- High Bandwidth: 350MHz
- Extended Industrial Temperature Range: -40°C to 85°C
- Packaging (Lead Free & Green): -12-pin TDFN, 3mm×1mm

Pin Assignment

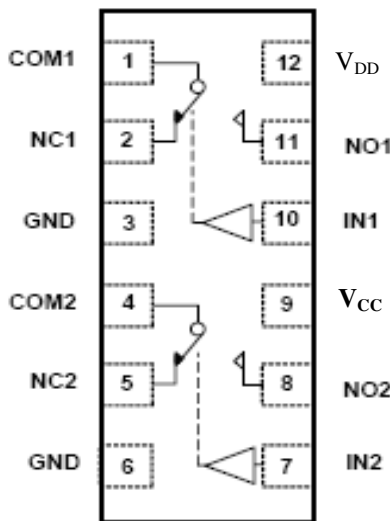

12-pin TDFN

Description

The PI5A3158B is a dual high-bandwidth, fast single-pole double-throw (SPDT) CMOS switch. It can be used as an analog switch or as a low-delay bus switch. Specified over a wide operating power supply voltage range, 1.65V to 5.5V, the PI5A3158B has a maximum ON resistance of 12-ohms at 1.65V, 9-ohms at 2.3V & 6-ohms at 4.5V.

Break-before-make switching prevents both switches being enabled simultaneously. This eliminates signal disruption during switching.

The control input, S, is independent of supply voltage.

Application

- Cell Phones
- PDAs
- MP3 Players
- Portable Instrumentation
- Battery powered Communications
- Computer Peripherals

Pin Description

Pin No	Name	Description
8, 11	₁ B _X	Data Port (Normally open)
3, 6	GND	Ground
2, 5	₀ B _X	Data Port (Normally closed)
1, 4	A _X	Common Output / Data Port
9, 12	V _{CC}	Positive Power Supply
7, 10	S _X	Logic Control

Logic Function Table

Logic Input (IN _x)	Function
0	₀ B _X Connected to A _X
1	₁ B _X Connected to A _X

Note: x = 1 or 2

Maximum Ratings

Storage Temperature.....	-65°C to +150°C
Ambient Temperature with Power Applied.....	-40°C to +85°C
Supply Voltage V _{CC}	-0.5V to +7.0V
DC Switch Voltage V _{IN}	-0.5V to V _{CC} +0.5V
Control Input Voltage V _S	-0.5V to +7.0V
DC Output Current V _{OUT}	128mA
DC V _{CC} or Ground Current I _{CC} / I _{GND}	±100mA
Junction Temperature under Bias (T _J)	150°C
Junction Lead Temperature (T _L) (Soldering, 10 seconds)	260°C
Power Dissipation (P _d) @ +85°C	180mW
ESD(HBM).....	2000V

Note:

Stresses greater than those listed under MAXIMUM RATINGS may cause permanent damage to the device. This is a stress rating only and functional operation of the device at these or any other conditions above those indicated in the operational sections of this specification is not implied. Exposure to absolute maximum rating conditions for extended periods may affect reliability.

Recommended Operating Conditions

Symbol	Parameter	Conditions	Min.	Typ.	Max.	Unit
V _{CC}	Operating Voltage	-	1.65	-	5.5	V
V _S	Control Input Voltage	-	0	-	5.5	V
V _{IN}	Switch Input Voltage	-	0	-	V _{CC}	V
V _{OUT}	Output Voltage	-	0	-	V _{CC}	V
T _A	Operating Temperature	-	-40	25	85	°C
t _r , t _f	Input Rise and Fall Time	Control Input V _{CC} = 2.3V - 3.6V	0	-	10	ns/V
		Control Input V _{CC} = 4.5V - 5.5V	0	-	5	ns/V

Note: Control input must be held HIGH or LOW; it must not float.

DC Electrical Characteristics

($T_A = -40^{\circ}\text{C}$ to 85°C , unless otherwise noted.)

Parameter	Description	Test Conditions	Temperature ($T_A: ^{\circ}\text{C}$)	Min.	Typ.	Max.	Units
V_{IAR}	Analog Input Signal Range	V_{CC}	-40°C to 85°C	0	-	V_{CC}	V
R_{ON}	ON Resistance ⁽¹⁾	$V_{CC}=4.5\text{V}, I_O = 30\text{mA}, V_{IN} = 0\text{V}$	25°C	-	4	6	Ω
		$V_{CC}=4.5\text{V}, I_O = -30\text{mA}, V_{IN} = 2.4\text{V}$		-	5	8	
		$V_{CC}=4.5\text{V}, I_O = -30\text{mA}, V_{IN} = 4.5\text{V}$		-	7	11	
		$V_{CC}=4.5\text{V}, I_O = 30\text{mA}, V_{IN} = 0\text{V}$	-40°C to 85°C	-	-	6	
		$V_{CC}=4.5\text{V}, I_O = -30\text{mA}, V_{IN} = 2.4\text{V}$		-	-	8	
		$V_{CC}=4.5\text{V}, I_O = -30\text{mA}, V_{IN} = 4.5\text{V}$		-	-	11	
		$V_{CC}=3.0\text{V}, I_O = 24\text{mA}, V_{IN} = 0\text{V}$	25°C	-	5	8	
		$V_{CC}=3.0\text{V}, I_O = -24\text{mA}, V_{IN} = 3.0\text{V}$		-	10	15	
		$V_{CC}=3.0\text{V}, I_O = 24\text{mA}, V_{IN} = 0\text{V}$		-40°C to 85°C	-	-	
		$V_{CC}=3.0\text{V}, I_O = -24\text{mA}, V_{IN} = 3.0\text{V}$	-		-	15	
		$V_{CC}=2.3\text{V}, I_O = 8\text{mA}, V_{IN} = 0\text{V}$	25°C		-	6	
		$V_{CC}=2.3\text{V}, I_O = -8\text{mA}, V_{IN} = 2.3\text{V}$		-	13	20	
		$V_{CC}=2.3\text{V}, I_O = 8\text{mA}, V_{IN} = 0\text{V}$		-40°C to 85°C	-	-	
		$V_{CC}=2.3\text{V}, I_O = -8\text{mA}, V_{IN} = 2.3\text{V}$	-		-	20	
		$V_{CC}=1.65\text{V}, I_O = 4\text{mA}, V_{IN} = 0\text{V}$	25°C		-	8	
		$V_{CC}=1.65\text{V}, I_O = -4\text{mA}, V_{IN} = 1.65\text{V}$		-	20	30	
		$V_{CC}=1.65\text{V}, I_O = 4\text{mA}, V_{IN} = 0\text{V}$		-40°C to 85°C	-	-	
		$V_{CC}=1.65\text{V}, I_O = -4\text{mA}, V_{IN} = 1.65\text{V}$	-		-	25	
ΔR_{ON}	ON Resistance Match Between Channels ^(1,2,3)	$V_{CC}=4.5\text{V}, I_A = -30\text{mA}, V_{Bn} = 3.15\text{V}$	25°C		-	0.15	-
		$V_{CC}=3.0\text{V}, I_A = -24\text{mA}, V_{Bn} = 2.1\text{V}$		-	0.2	-	
		$V_{CC}=2.3\text{V}, I_A = -8\text{mA}, V_{Bn} = 1.6\text{V}$		-	0.3	-	
		$V_{CC}=1.65\text{V}, I_A = -4\text{mA}, V_{Bn} = 1.15\text{V}$		-	0.5	-	
R_{ONF}	ON Resistance Flatness ^(1,2,4)	$V_{CC}=5.0\text{V}, I_A = -30\text{mA}, 0 \leq V_{Bn} \leq V_{CC}$	25°C	-	6	-	Ω
		$V_{CC}=3.3\text{V}, I_A = -24\text{mA}, 0 \leq V_{Bn} \leq V_{CC}$		-	12	-	
		$V_{CC}=2.5\text{V}, I_A = -8\text{mA}, 0 \leq V_{Bn} \leq V_{CC}$		-	22	-	
		$V_{CC}=1.8\text{V}, I_A = -4\text{mA}, 0 \leq V_{Bn} \leq V_{CC}$		-	90	-	
V_{IH}	Input High Voltage (Logic High Level)	$V_{CC}=1.65\text{V}$	-40°C to 85°C	1	-	-	V
		$V_{CC} = 2.3\text{V}$		1.2	-	-	
		$V_{CC} = 3\text{V}$		1.3	-	-	
		$V_{CC} = 4.2\text{V}$		1.5	-	-	
		$V_{CC} = 5.5\text{V}$		1.8	-	-	
V_{IL}	Input Low Voltage (Logic Low Level)	$V_{CC}=1.65\text{V}$	-40°C to 85°C	-	-	0.4	V
		$V_{CC} = 2.3\text{V}$		-	-	0.6	
		$V_{CC} = 3\text{V}$		-	-	0.8	
		$V_{CC} = 4.2\text{V}$		-	-	1	
		$V_{CC} = 5.5\text{V}$		-	-	1.2	
I_{LKC}	Input Leakage Current	$0 \leq V_{IN} \leq 5.5\text{V}, V_{CC} = 0\text{V}$ to 5.5V	25°C	-	-	± 0.1	μA
			-40°C to 85°C	-	-	± 1.0	
I_{OFF}	OFF State Leakage Current	$0 \leq V_{IN} \leq 5.5\text{V}, V_{CC} = 1.65\text{V}$ to 5.5V	25°C	-	-	± 0.1	μA
			-40°C to 85°C	-	-	± 10	
I_{CC}	Quiescent Supply Current	All channels ON or OFF, $V_{IN} = V_{CC}$ or GND, $I_{OUT} = 0, V_{CC} = 5.5\text{V}$	25°C	-	-	1	μA
			-40°C to 85°C	-	-	5	

Notes:

- Measured by voltage drop between A and B pins at the indicated current through the device. ON resistance is determined by the lower of the voltages on two ports (A or B).
- Parameter is characterized but not tested in production.
- $\Delta R_{ON} = R_{ON} \text{ max} - R_{ON} \text{ min}$. measured at identical V_{CC} , temperature and voltage levels.
- Flatness is defined as difference between maximum and minimum value of ON resistance over the specified range of conditions. Guaranteed by design.

Capacitance⁽¹⁾
($T_A = 25^\circ\text{C}$, unless otherwise noted.)

Symbol	Parameter	Test Conditions	Min.	Typ.	Max.	Units
C_{IN}	Control Input	$V_{CC} = 5.0\text{V}$	-	2.5	-	pF
C_{IO-B}	For B Port, Switch OFF	$V_{CC} = 5.0\text{V}, f = 1\text{ MHz}$ ⁽¹⁾	-	5.0	-	
C_{IOA-ON}	For A Port, Switch ON		-	15.0	-	

Notes:

1. Capacitance is characterized but not tested in production

Switch and AC Characteristics⁽¹⁾

Parameter	Description	Test Conditions	Supply Voltage	Temperature ($T_A: ^\circ\text{C}$)	Min.	Typ.	Max.	Units
t_{PLH} t_{PHL}	Propagation Delay: A to Bn	See test circuit diagrams 1 and 2. V_I Open ⁽²⁾	$V_{CC} = 2.3\text{V to } 2.7\text{V}$	-40 to 85°C	-	0.7	-	ns
			$V_{CC} = 3.0\text{V to } 3.6\text{V}$		-	0.6	-	
			$V_{CC} = 4.5\text{V to } 5.5\text{V}$		-	0.4	-	
t_{PZL} t_{PZH}	Output Enable Turn ON Time: A to Bn	See test circuit diagrams 1 & 2. $V_I = 2V_{CC}$ for t_{PZL} , $V_I = 0\text{V}$ for t_{PZH}	$V_{CC} = 1.65\text{V to } 1.95\text{V}$	-40 to 85°C	-	9	-	
			$V_{CC} = 2.3\text{V to } 2.7\text{V}$		-	5	-	
			$V_{CC} = 3.0\text{V to } 3.6\text{V}$		-	3	-	
			$V_{CC} = 4.5\text{V to } 5.5\text{V}$		-	2	-	
t_{PLZ} t_{PHZ}	Output Disable Turn OFF Time: A to Bn	See test circuit diagrams 1 and 2. $V_I = 2V_{CC}$ for t_{PLZ} , $V_I = 0\text{V}$ for t_{PHZ}	$V_{CC} = 1.65\text{V to } 1.95\text{V}$	-40 to 85°C	-	9	-	
			$V_{CC} = 2.3\text{V to } 2.7\text{V}$		-	6	-	
			$V_{CC} = 3.0\text{V to } 3.6\text{V}$		-	5	-	
			$V_{CC} = 4.5\text{V to } 5.5\text{V}$		-	3	-	
t_{BM}	Break Before Make Time	See test circuit diagram 3.	$V_{CC} = 1.65\text{V to } 1.95\text{V}$	-40 to 85°C	0.5	-	-	
			$V_{CC} = 2.3\text{V to } 2.7\text{V}$		0.5	-	-	
			$V_{CC} = 3.0\text{V to } 3.6\text{V}$		0.5	-	-	
			$V_{CC} = 4.5\text{V to } 5.5\text{V}$		0.5	-	-	
Q	Charge Injection	$C_L = 0.1\text{nF}, V_{GEN} = 0\text{V}, R_{GEN} = 0\Omega$ See test circuit 4.	$V_{CC} = 5.0\text{V}$	25°C	-	5	-	pC
			$V_{CC} = 3.3\text{V}$		-	4	-	
OIRR	Off Isolation	$R_L = 50\Omega, V_{GEN} = 0\text{V}, R_{GEN} = 0\Omega, f = 10\text{MHz}$. See test circuit 5. ⁽³⁾	$V_{CC} = 1.65\text{V to } 5.5\text{V}$	25°C	-	-63	-	dB
X_{TALK}	Crosstalk Isolation	See test circuit 6. ⁽⁴⁾	$V_{CC} = 1.65\text{V to } 5.5\text{V}$	25°C	-	-64	-	
f _{3dB}	-3dB Bandwidth	See test circuit 9	$V_{CC} = 1.65\text{V to } 5.5\text{V}$	25°C	-	350	-	MHz

Notes:

- Guaranteed by design.
- The device contributes no other propagation delay other than the RC delay of the switch ON resistance and the 50pF load capacitance, when driven by an ideal voltage source with zero output impedance.
- Off Isolation = $20 \text{ Log}_{10} [V_{Bn}/V_A]$ and is measured in dB.
- Crosstalk Isolation = $20 \text{ Log}_{10} [V_{B1}/V_{B0}]$ and is measured in dB.

Test Circuits and Timing Diagrams

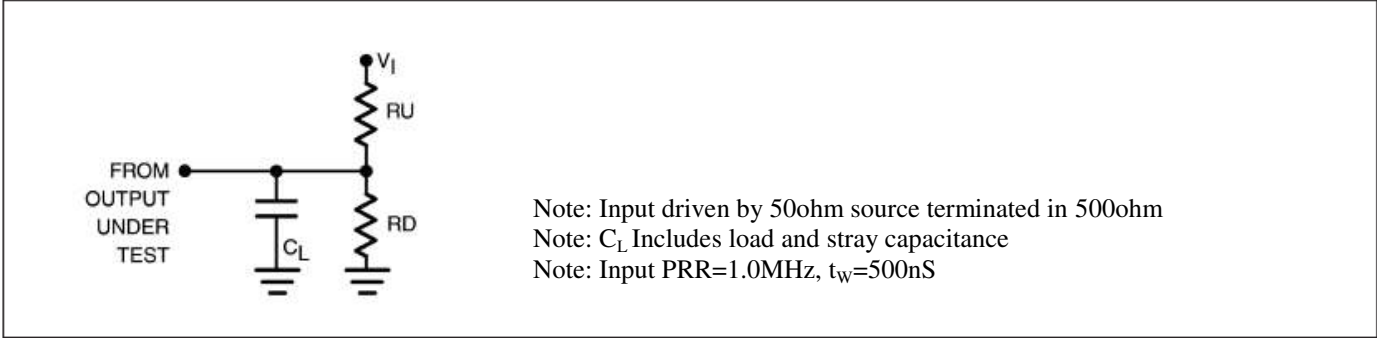

Figure 1. AC Test Circuit

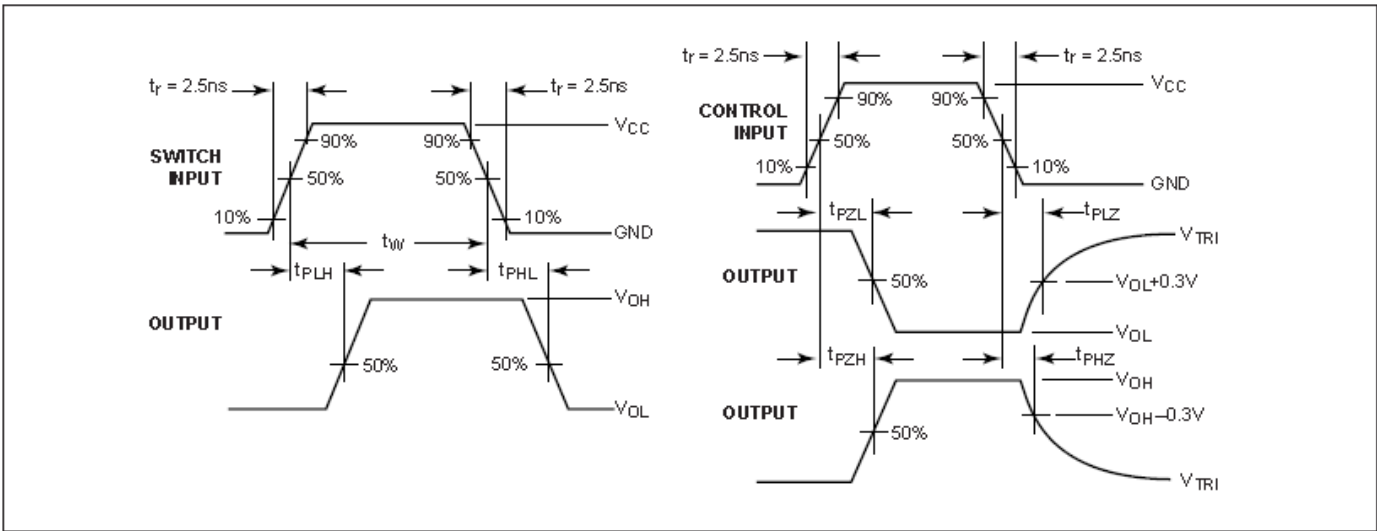

Figure 2. AC Waveforms

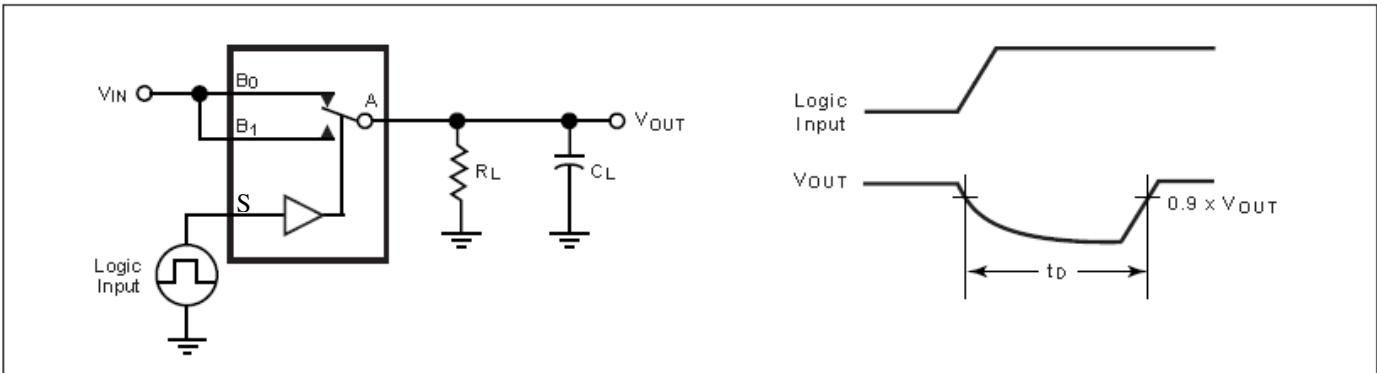

Figure 3. Break Before Make Interval Timing

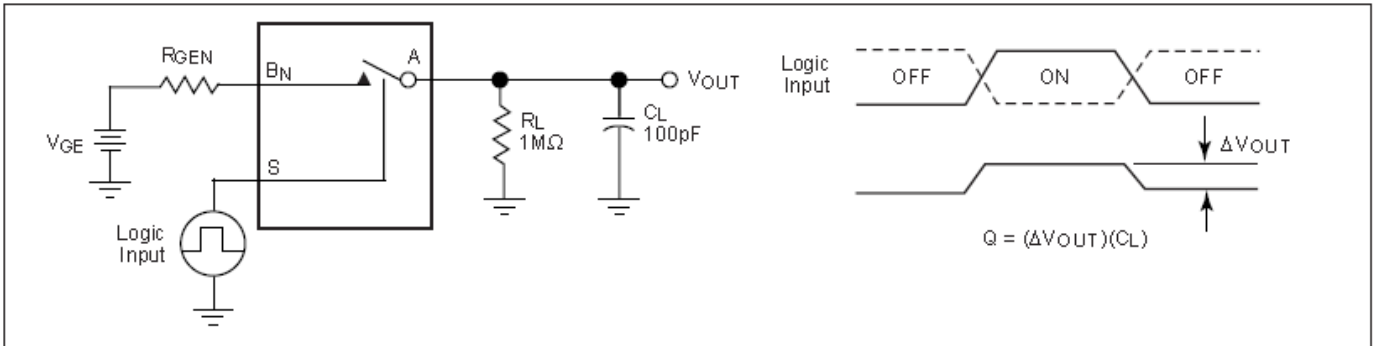

Figure 4. Charge Injection Test

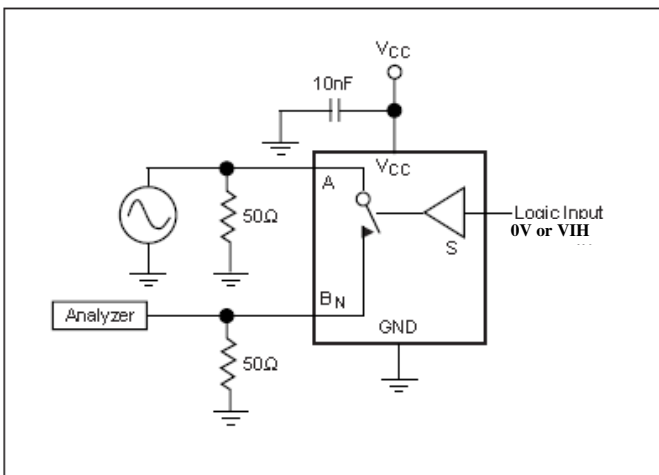

Figure 5. Off Isolation

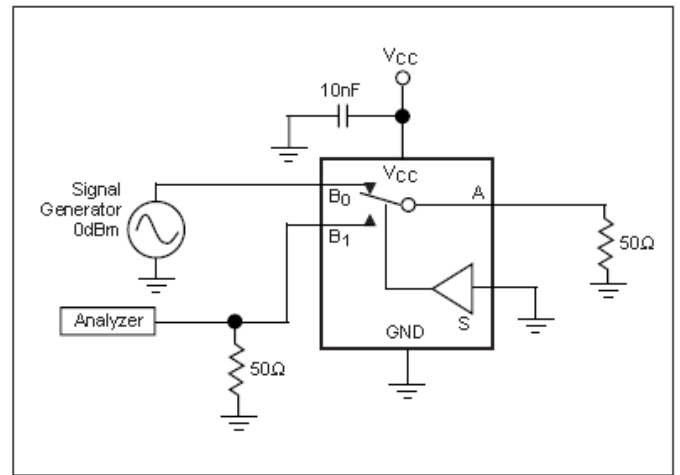

Figure 6. Crosstalk

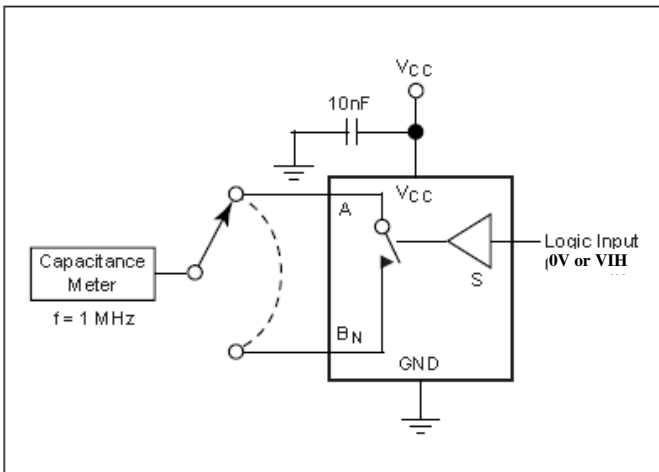

Figure 7. Channel Off Capacitance

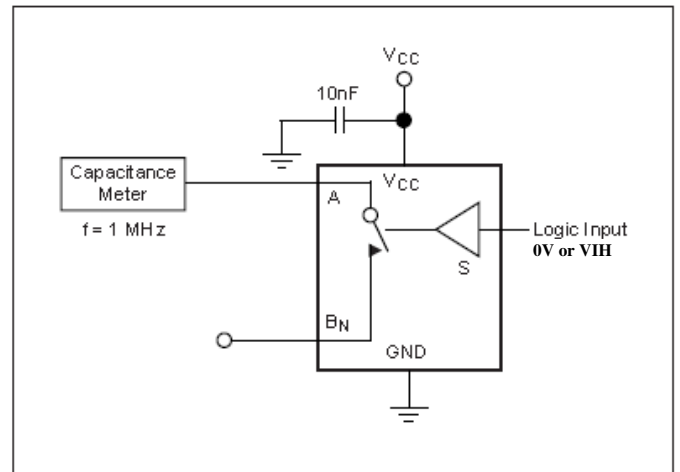

Figure 8. Channel On Capacitance

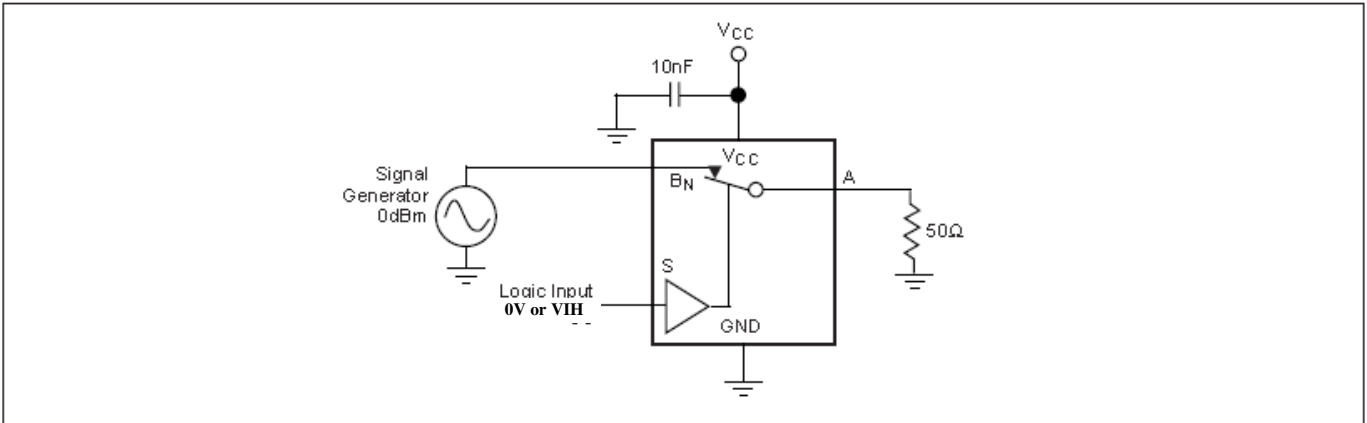
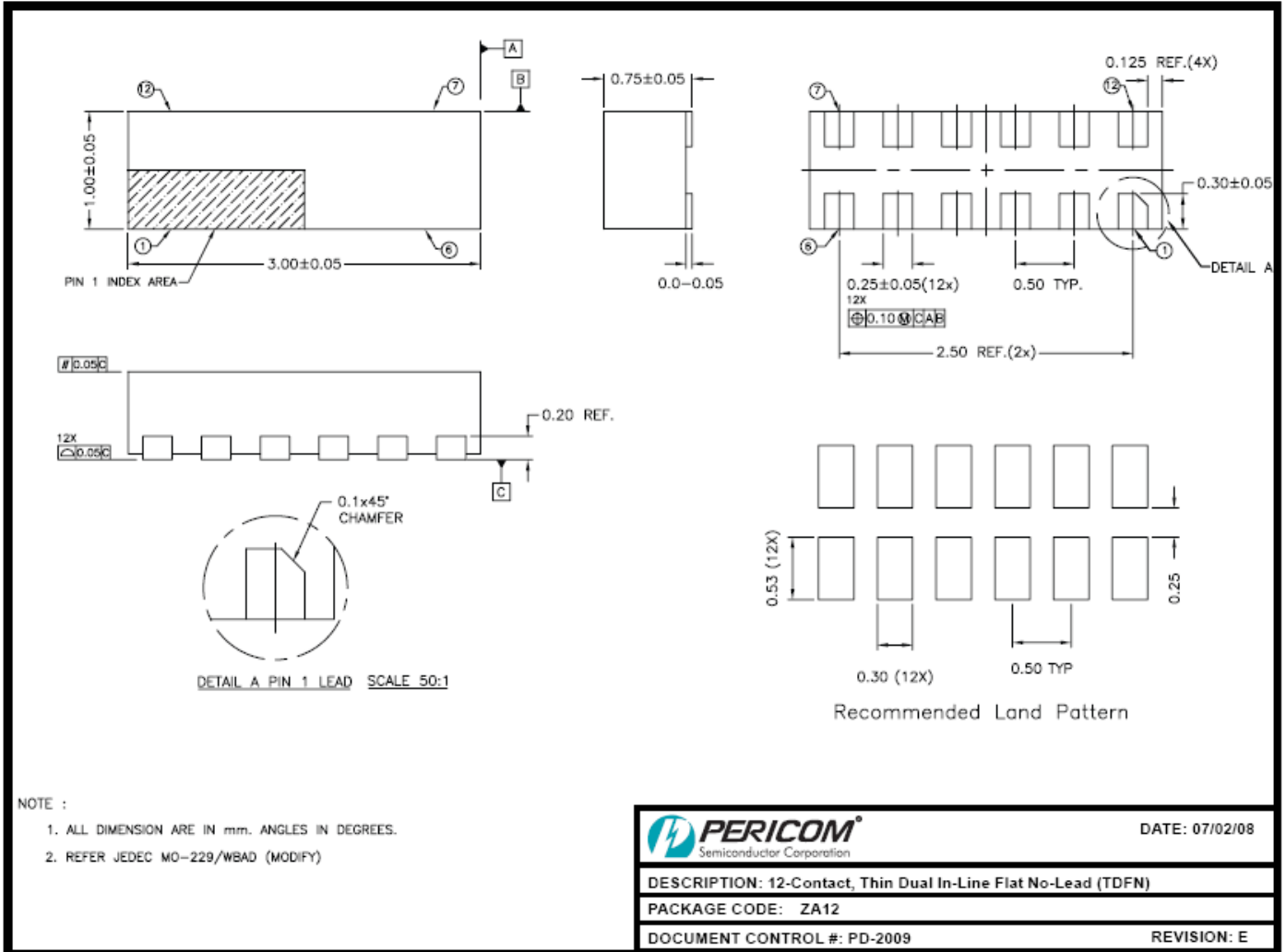

Figure 9. Bandwidth

Mechanical Information

12-pin TDFN (ZA)



Note: For latest package info, please check: <http://www.pericom.com/support/packaging/packaging-mechanicals-and-thermal-characteristics/>

Ordering Information

Part Number	Package Code	Package	Top Marking
PI5A3158BZAE	ZA	12-Contact, Thin Dual In-Line Flat No-Lead (TDFN)	kE
PI5A3158BZAEX	ZA	12-Contact, Thin Dual In-Line Flat No-Lead (TDFN) , Tape & Reel	kE

Note:

- Thermal characteristics can be found on the company web site at www.pericom.com/packaging/
- E = Pb-free and Green
- Adding X Suffix= Tape/Reel