

THIS DRAWING IS UNPUBLISHED. RELEASED FOR PUBLICATION

© COPYRIGHT - TE Connectivity Ltd.

ALL RIGHTS RESERVED.

REVISIONS

P	LTR	DESCRIPTION	DATE	DWN	APVD
B		ECR-17-013893	10JAN2018	FL	HL

NOTE:

- MATERIAL:
HOUSING: PA9T WITH 30% GF, UL94 V-0, COLOR: SEE TABLE.
CAP: LCP WITH 30% GF, UL94 V-0, COLOR: BLACK.
CONTACTS: PHOSPHOR BRONZE.
- FINISH:
CONTACTS:
GOLD PLATING (SEE TABLE) ON CONTACT AREA.
2.54um [100u"] MIN. MATTE-TIN ON SOLDER TAIL.
1.27um [50u"] MIN. NICKEL UNDERPLATED OVERALL.
- REFLOW SOLDER CAPABLE TO 260°C PER TEST SPEC. TEC-109-201, CONDITION B.
⚠ STRADDLE MOUNT PCB THICKNESS OPTION.
⚠ FOR REFLOW PROCESS, THE CAP MUST BE ATTACHED, IT WILL PROTECT HOUSING WARPAGE.

ACCEPTED ADD-IN CARD
PCB THICKNESS = 1.57mm
(SEE PAGE 3)

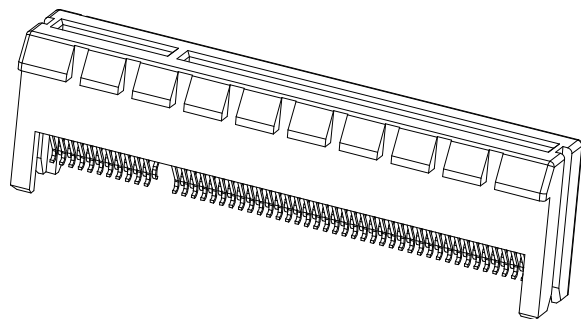
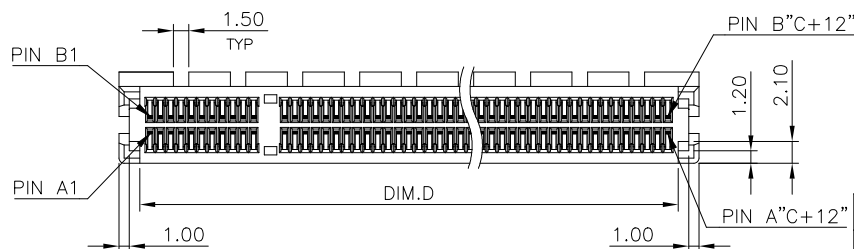
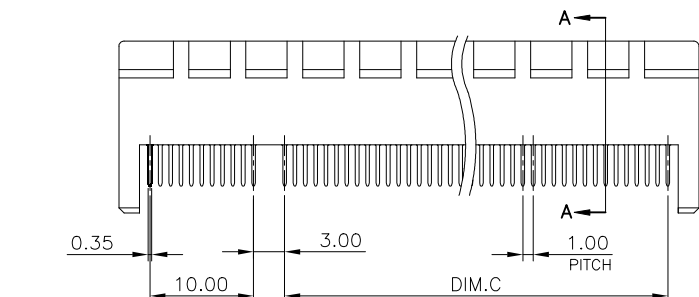
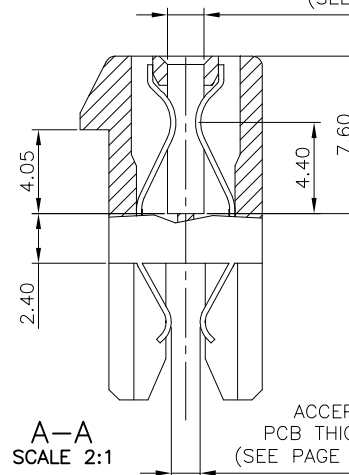
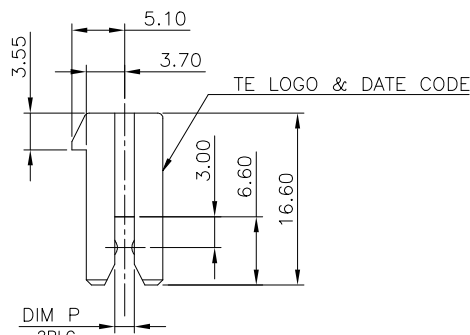
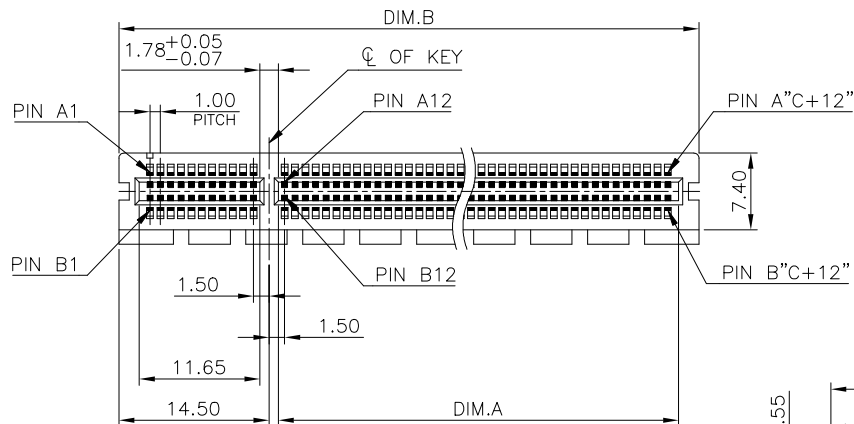

11.10	85	70.0	89	71.65	2.00	1.80 [0.071"]	0.762um[30u"]	BLACK	164	2041313-4
3.20	21	6.0	25	7.65					36	2041313-1
NET WEIGHT(g)	DIM D	DIM C	DIM B	DIM A	DIM P	ACCEPTED PCB THICKNESS ⚠	MIN. GOLD THICKNESS	HOUSING COLOR	POS.	PART NUMBER

THIS DRAWING IS A CONTROLLED DOCUMENT.

DIMENSIONS: mm	TOLERANCES UNLESS OTHERWISE SPECIFIED: 0 PLC ± - 1 PLC ± 0.3 2 PLC ± 0.2 3 PLC ± 0.15 4 PLC ± - ANGLES ± 3'	DWN E. LIU 11MAR2011	TE Connectivity Ltd. PCI EXPRESS CARD EDGE CONNECTOR STRADDLE MOUNT TYPE
		CHK S. CHIEN 11MAR2011	
		APVD W. KODAMA 11MAR2011	
		NAME 108-57854	
MATERIAL SEE NOTE	FINISH SEE NOTE	APPLICATION SPEC -	SIZE A3
		WEIGHT 0	CAGE CODE 00779
		CUSTOMER DRAWING	DRAWING NO C=2041313
		SCALE 1:1	RESTRICTED TO -
		SHEET 1 OF 4	REV B

4

3

2

1

THIS DRAWING IS UNPUBLISHED.

RELEASED FOR PUBLICATION

-. - .

© COPYRIGHT - TE Connectivity Ltd.

ALL RIGHTS RESERVED.

REVISIONS

P	LTR	DESCRIPTION	DATE	DWN	APVD
-	-	SEE SHEET 1	-	-	-

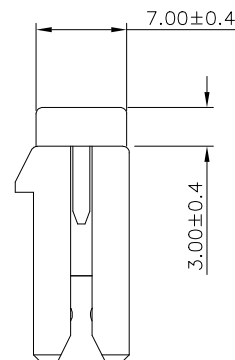
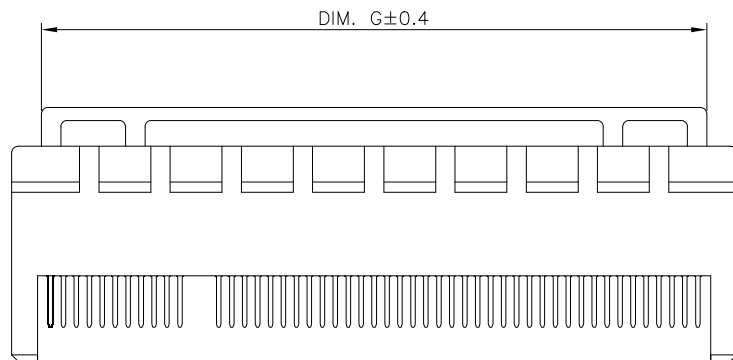
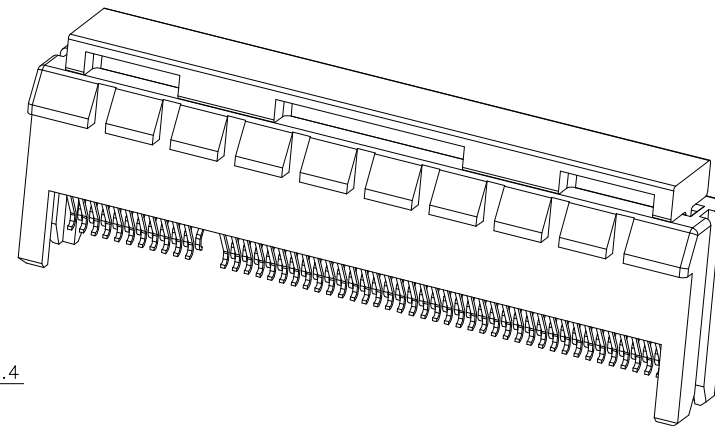
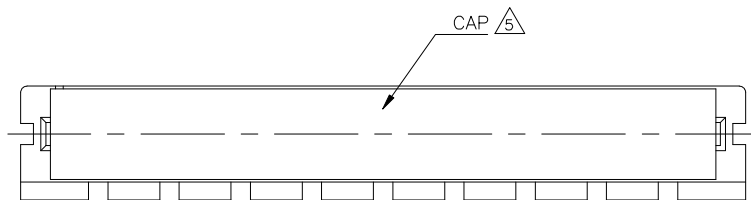

5 ASSEMBLY WITH CAP CONDITION

164	84.4
36	20.4
POS.	DIM G

THIS DRAWING IS A CONTROLLED DOCUMENT.		DWN E. LIU 11MAR2011	TE Connectivity Ltd.	
		CHK S. CHIEN 11MAR2011		
DIMENSIONS: mm		APVD W. KODAMA 11MAR2011	NAME	
		PRODUCT SPEC	PCI EXPRESS CARD EDGE CONNECTOR STRADDLE MOUNT TYPE	
TOLERANCES UNLESS OTHERWISE SPECIFIED: 0 PLC ± - 1 PLC ± 0.3 2 PLC ± 0.2 3 PLC ± 0.15 4 PLC ± - ANGLES ± 3°		APPLICATION SPEC	108-57854	
MATERIAL SEE NOTE		WEIGHT 0	SIZE A3	CAGE CODE 00779
FINISH SEE NOTE		DRAWING NO C=2041313		RESTRICTED TO -
CUSTOMER DRAWING			SCALE 1:1	SHEET 2 OF 4
			REV B	

THIS DRAWING IS UNPUBLISHED. RELEASED FOR PUBLICATION
 © COPYRIGHT - TE Connectivity Ltd. ALL RIGHTS RESERVED.

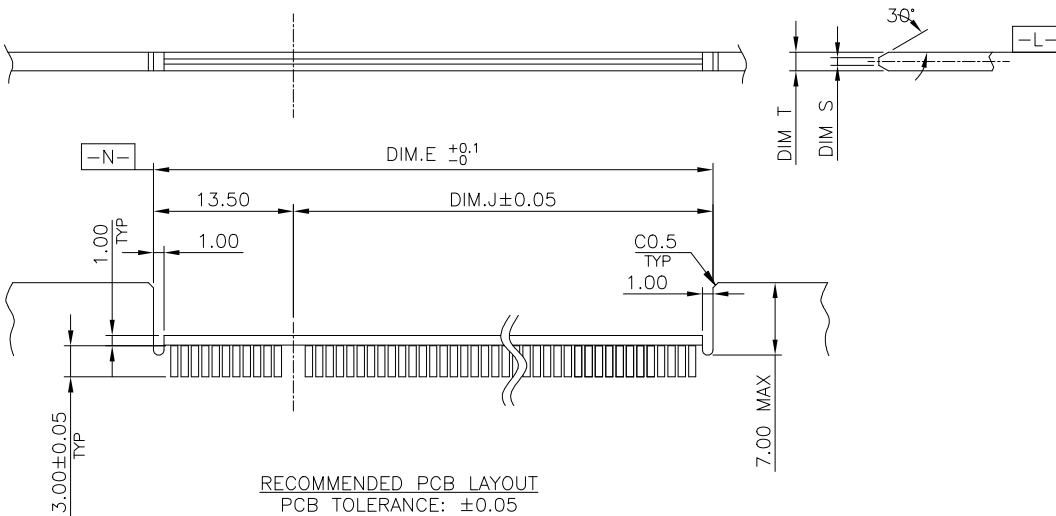
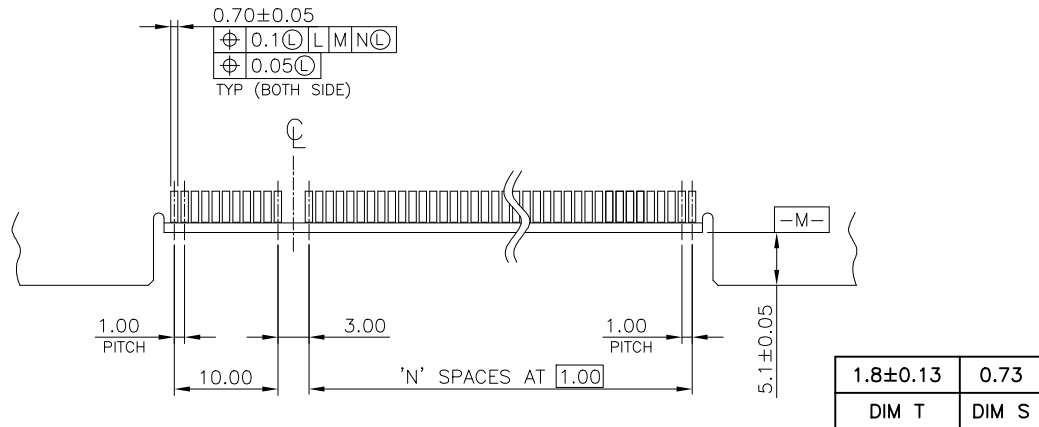

- ⚠ NO TIE BAR PERMITTED FROM CARD EDGE TO LEADING EDGE OF PAD FOR PINS A1 AND "K"
- ⚠ CHAMFER EDGE MUST BE FREE OF CUTTING BURRS

REVISIONS					
P	LTR	DESCRIPTION	DATE	DWN	APVD
-	-	SEE SHEET 1	-	-	-

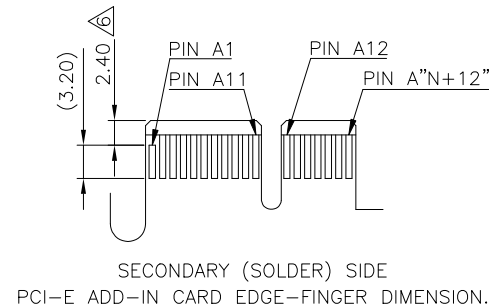
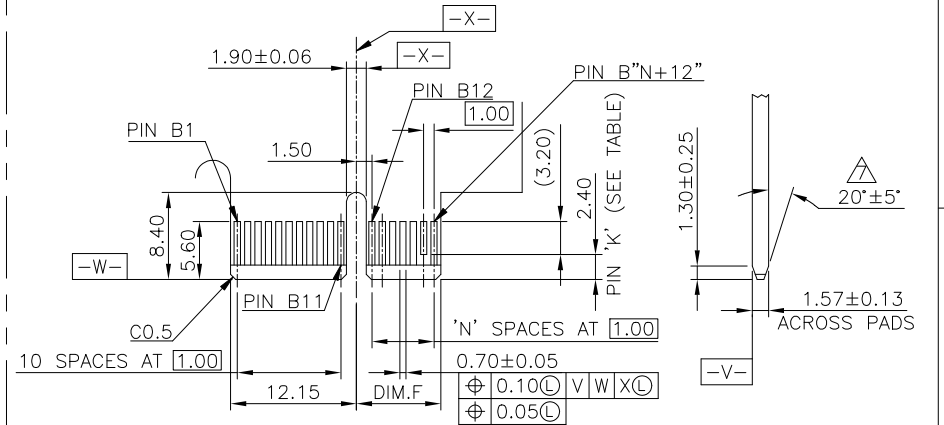

164	70	87	73.5	72.15	B17, B31, B48, B81
36	6	23	9.	8.15	B17
POS	N	DIM E	DIM J	DIM F	"K"

THIS DRAWING IS A CONTROLLED DOCUMENT.

DWN E. LIU 11MAR2011	TE Connectivity Ltd. PCI EXPRESS CARD EDGE CONNECTOR STRADDLE MOUNT TYPE				
CHK S. CHIEN 11MAR2011					
APVD W. KODAMA 11MAR2011					
NAME 108-57854					
MATERIAL SEE NOTE	FINISH SEE NOTE	SIZE A3	CAGE CODE 00779	DRAWING NO C=2041313	RESTRICTED TO -
CUSTOMER DRAWING			SCALE 1:1	SHEET 3 OF 4	REV B

THIS DRAWING IS UNPUBLISHED.

RELEASED FOR PUBLICATION

-. - .

© COPYRIGHT - TE Connectivity Ltd.

ALL RIGHTS RESERVED.

REVISIONS

P	LTR	DESCRIPTION	DATE	DWN	APVD
-	-	SEE SHEET 1	-	-	-

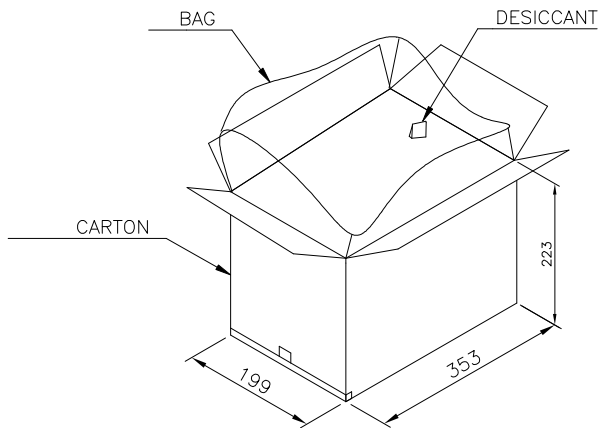
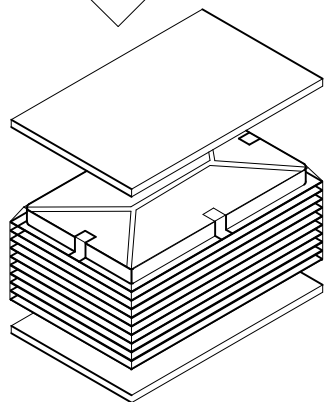
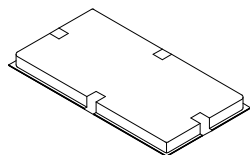
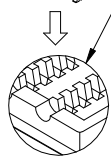
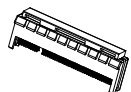
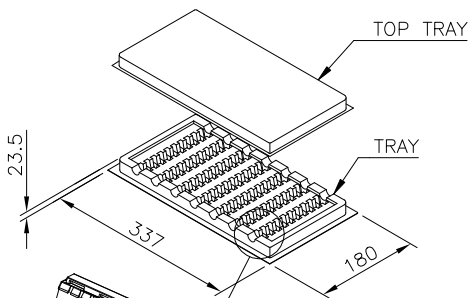

- MATERIAL :
 TRAY: PVC, COLOR: TRANSPARENT.
 CARTON: CORRUGATED FIBER
 BOX: CORRUGATED FIBER
 TRANSPARENT BAG: PE, SIZE: 480mm*350mm*0.06mm
 600mm*590mm*0.06mm
- EACH BAG SHALL BE INCLUDED:
 * DESICCANT

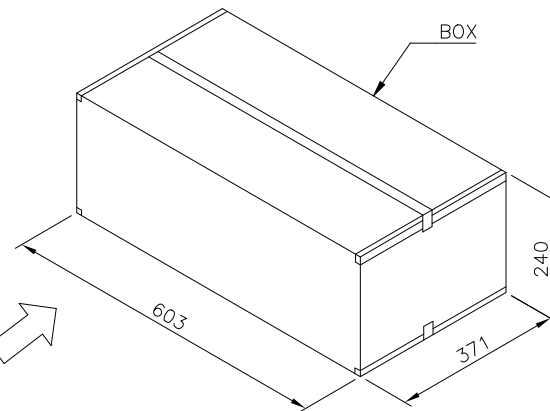
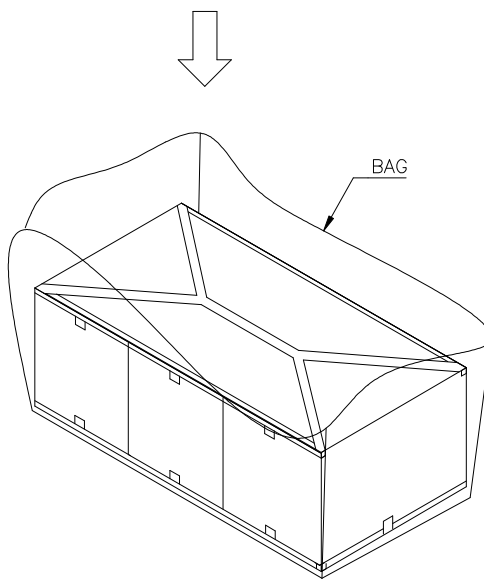

THIS DRAWING IS A CONTROLLED DOCUMENT.		DWN E. LIU 11MAR2011	STE TE Connectivity Ltd.	
		CHK S. CHIEN 11MAR2011		
DIMENSIONS: mm		APVD W. KODAMA 11MAR2011	NAME	
TOLERANCES UNLESS OTHERWISE SPECIFIED:		PRODUCT SPEC		PCI EXPRESS CARD EDGE CONNECTOR STRADDLE MOUNT TYPE
0 PLC ± - 1 PLC ± - 2 PLC ± - 3 PLC ± - 4 PLC ± - ANGLES ± -		APPLICATION SPEC		
MATERIAL SEE NOTE		WEIGHT 0	SIZE A3	CAGE CODE 00779
FINISH SEE NOTE		DRAWING NO C=2041313		RESTRICTED TO -
CUSTOMER DRAWING			SCALE 1:1	SHEET 4 OF 4
			REV B	