

Product Number	DIM "A"	DIM "B"	DIM "C"	DIM "D"	Packaging
10126907-101LF	7.20	9.80	3.60	3.60	Tray

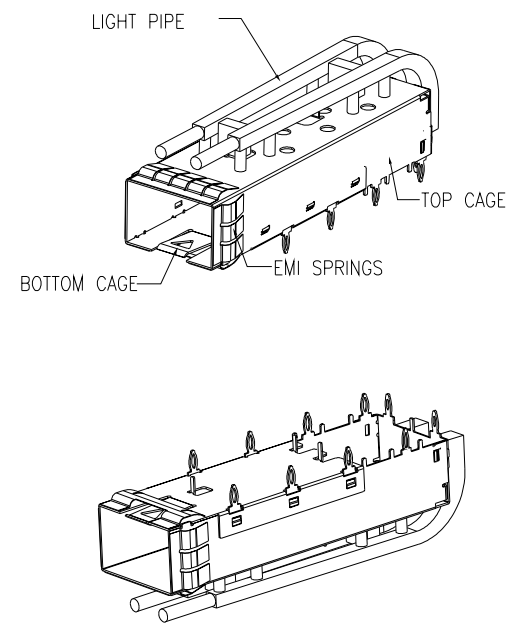
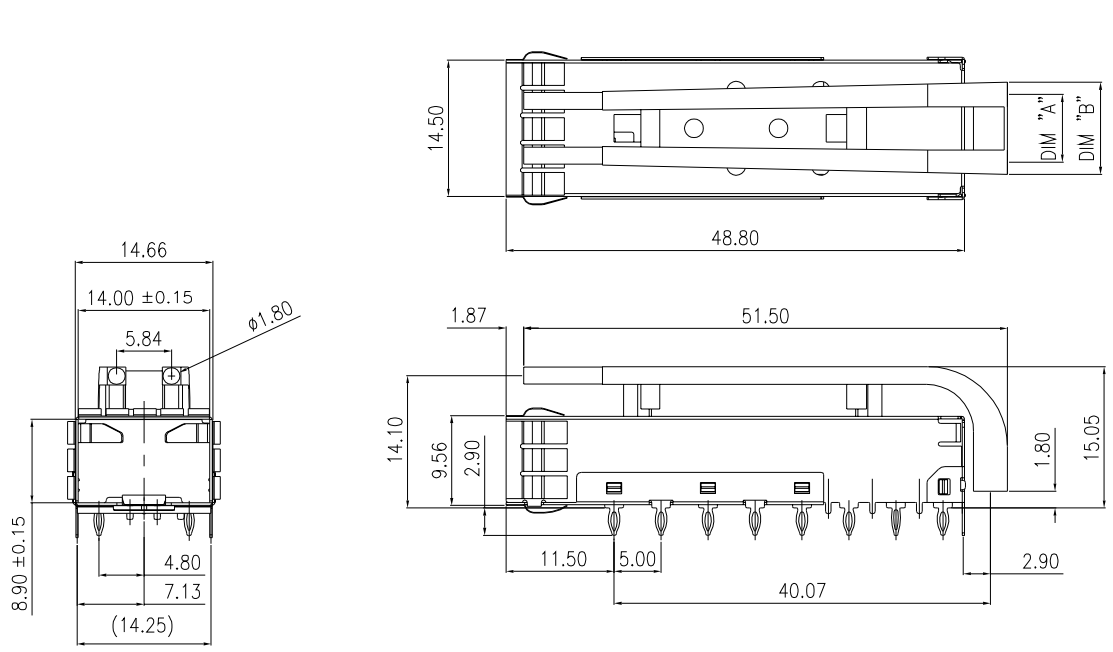

- NOTES:
- |                |      |                            |            |
|----------------|------|----------------------------|------------|
| 1, DESCRIPTION | Q'ty | MATERIAL                   | PLATING    |
| TOP CAGE       | 1PCS | NICKEL SILVER ALLOY T=0.25 | NO PLATING |
| BOTTOM CAGE    | 1PCS | NICKEL SILVER ALLOY T=0.25 | NO PLATING |
| EMI SPRINGS    | 1PCS | COPPER ALLOY T=0.08        | Ni PLATED  |
| LIGHT PIPE     | 1PCS | POLYCARBONATE, CLEAR       | N/A        |
- 2, PRODUCT SPECIFICATION: GS-12-1165  
3, APPLICATION SPECIFICATION: GS-20-0384  
4, PACKAGE PER GS-14-2344 AND GS-14-920

spec ref	RELEASE	dr	Art Lin	2014-01-13	projection 	MM ←→	size	scale
tolerance std	TOLERANCES UNLESS OTHERWISE SPECIFIED	eng	Zhen Luo	2014-01-13			A4	1:1
ISO406		chr	Collins Lu	2014-01-14			ecn no	
ISO1101		appr	JEFFREY QIN	2014-01-14	product family	SFP+	rel level	Released
surface	linear	0.X	±0.25		title	dwg no	10126907	rev
ISO1302		0.XX	±0.20					
	0.XXX	±0.15						
	angular	0°	±0.5°					
		www.fci.com	cat. no.	-	Product-Customer Drw	sheet 1 of 3		

Proj/E File - REV C - 2009-06-09



Copyright FCI.

Product Number	DIM "A"	DIM "B"	DIM "C"	DIM "D"	Packaging
10126907-2011LF	9.60	12.20	4.80	4.80	Tray

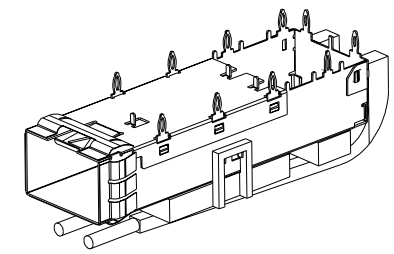
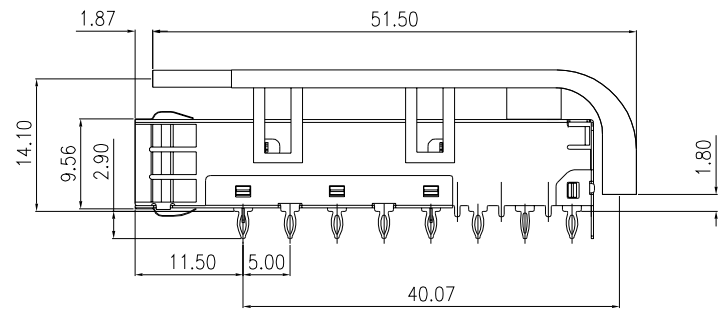
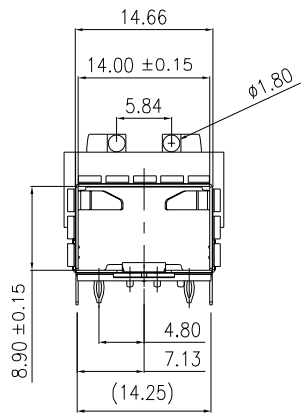
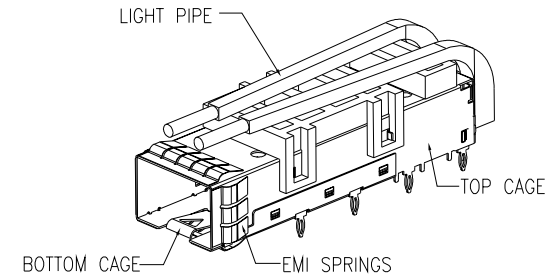
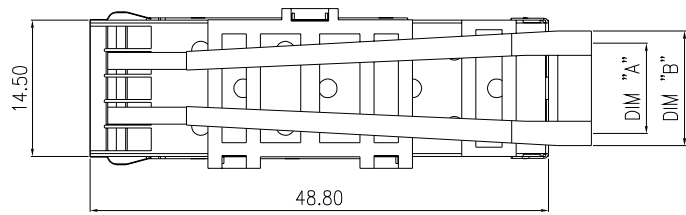

Copyright FCI.

spec ref	RELEASE			dr	Art Lin	2014-01-13	projection 	MM ←→	size	A4	scale	1:1
tolerance std	TOLERANCES UNLESS OTHERWISE SPECIFIED			eng	Zhen Luo	2014-01-13			ecn no			
ISO406 ISO1101				chr	Collins Lu	2014-01-14			rel level	Released		
surface	linear	0.X	±0.25	 <a href="http://www.fci.com">www.fci.com</a>	<b>title</b> SFP+ 1X1 CAGE ASSEMBLY EMI SPRING TYPE PRESS FIT WITH LIGHTPIPE <b>cat. no.</b> -			<b>dwg no</b> 10126907	<b>rev</b> C			
ISO1302		0.XX	±0.20									
	0.XXX	±0.15										
	angular	0°	±0.5°									Product-Customer Drw

Pro/E File - REV C - 2009-06-09

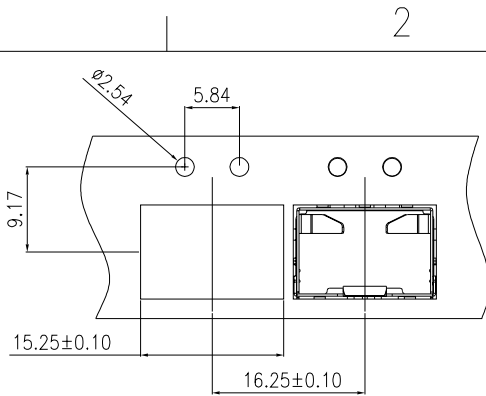

RECOMMENDED BEZEL CUT-OUT SINGLE SIDED APPLICATIONS

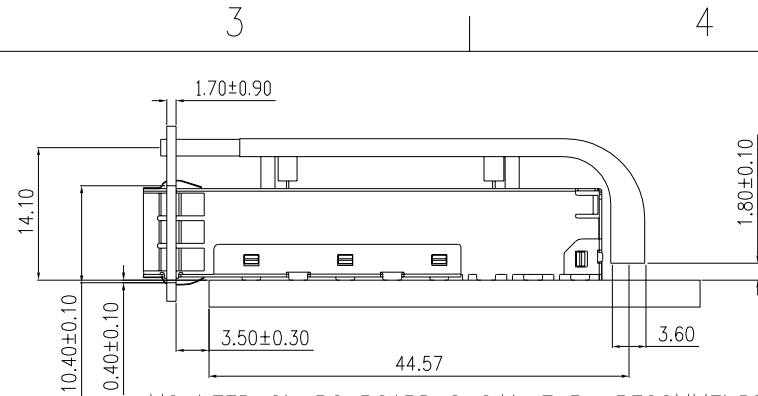

MOUNTED ON PC BOARD SHOWN THRU RECOMMENDED BEZEL  
(10126907-201LF POSITION IS SAME TO 10126907-101LF)

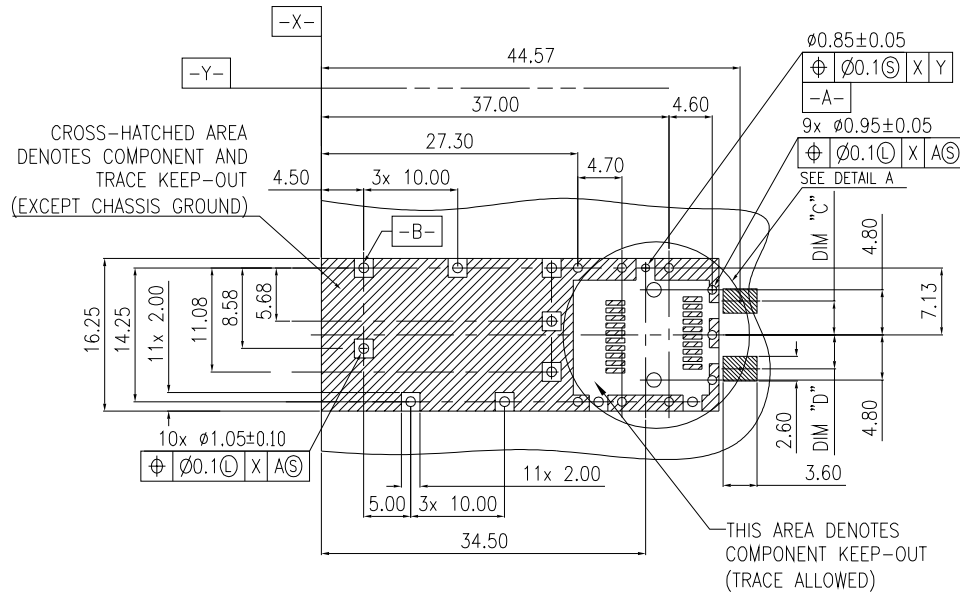

PCB LAYOUT THICKNESS=3.0mm (TOP VIEW)

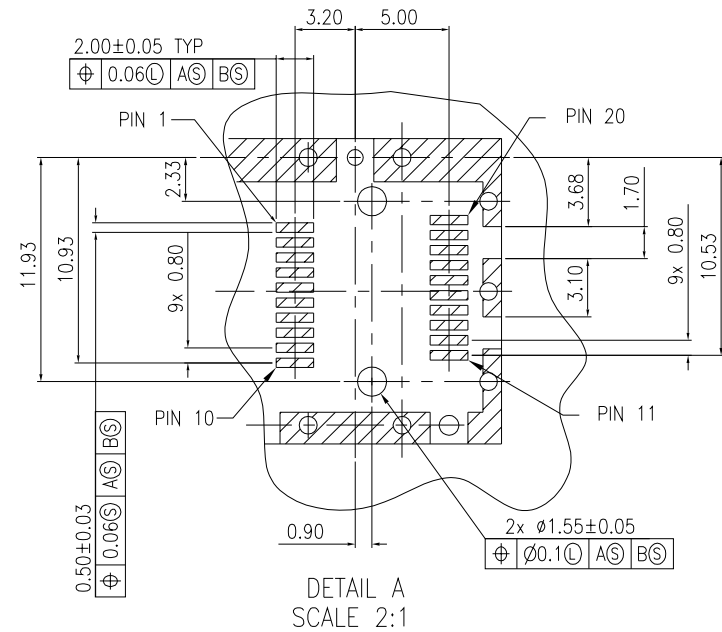

DETAIL A  
SCALE 2:1



Copyright FCI.

spec ref	RELEASE	dr	Art Lin	2014-01-13	projection	size	scale
tolerance std	TOLERANCES UNLESS OTHERWISE SPECIFIED	eng	Zhen Luo	2014-01-13		A4	1:1
ISO406		chr	Collins Lu	2014-01-14		ecn no	
ISO1101		appr	JEFFREY QIN	2014-01-14	product family	SFP+	rel level
surface			<b>FCI</b> title SFP+ 1X1 CAGE ASSEMBLY EMI SPRING TYPE PRESS FIT WITH LIGHTPIPE www.fci.com cat. no.	-	Product-Customer Drw	dwg no 10126907	rev
ISO1302							C
						sheet 3 of 3	

Proj/E File - REV C - 2009-06-09